

United States Department of Energy

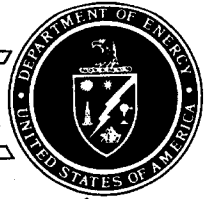

LONG-TERM SURVEILLANCE PLAN FOR THE GREEN RIVER, UTAH DISPOSAL SITE

JULY 1998

NON-RECORD

NON-RECORD

L. J. R. V. 01.01



Uranium Mill Tailings Remedial Action Project

**DOE/AL/62350-89
REV. 2**

**LONG-TERM SURVEILLANCE PLAN
FOR THE GREEN RIVER, UTAH
DISPOSAL SITE**

JULY 1998

**Prepared for
U.S. Department of Energy
UMTRA Project Team
Environmental Restoration Division
Albuquerque, New Mexico**

**Prepared by
Jacobs Engineering Group Inc.
Albuquerque, New Mexico**

<u>Section</u>	TABLE OF CONTENTS	<u>Page</u>
1.0	INTRODUCTION	1-1
1.1	Background	1-2
1.2	Licensing process	1-2
1.3.	Acquisition	1-2
1.4	Long-term surveillance plan	1-3
2.0	FINAL SITE CONDITIONS	2-1
2.1	Site history	2-1
2.2	Final site conditions	2-1
2.2.1	Description and location of the disposal site area	2-1
2.2.2	Disposal site access and security	2-1
2.2.3	Disposal cell design	2-4
3.0	SITE DRAWINGS AND PHOTOGRAPHS	3-1
3.1	Disposal site map and drawings	3-1
3.1.1	Disposal site vicinity map	3-1
3.1.2	Disposal site map	3-1
3.1.3	Disposal site as-built drawings	3-2
3.2	Site baseline photographs	3-2
3.3	Site aerial photographs	3-3
3.4	Site inspection photographs	3-3
4.0	PERMANENT SITE SURVEILLANCE FEATURES	4-1
4.1	Survey monuments	4-1
4.2	Boundary monuments.....	4-1
4.3	Site markers	4-1
4.4	Entrance and perimeter signs	4-7
4.5	Settlement plates	4-7
4.6	Additional site surveillance features	4-7
4.7	Reference posts	4-10
5.0	GROUND WATER MONITORING	5-1
5.1	Ground water characterization	5-1
5.1.1	Hydrogeologic setting	5-1
5.1.2	Ground water quality	5-5
5.1.3	Extent of contamination	5-5
5.2	Ground water monitoring program.....	5-6
5.2.1	Previous ground water monitoring	5-6
5.2.2	Post-closure ground water monitoring	5-7
5.3	Corrective action plan	5-8
5.4	Data validation and quality assurance	5-9
5.5	Reporting	5-9
6.0	SITE INSPECTIONS	6-1
6.1	Inspection frequency	6-1
6.2	Inspection team	6-1

TABLE OF CONTENTS (Continued)

<u>Section</u>	<u>Page</u>
6.3 Preparation for inspection.....	6-1
6.4 Site inspection and inspection checklist	6-2
6.4.1 Modifying processes	6-4
6.4.2 Vegetation	6-4
6.5 Site inspection map	6-5
6.6 Reporting requirements	6-5
7.0 UNSCHEDULED INSPECTIONS	7-1
7.1 Follow-up inspections	7-1
7.2 Contingency inspections	7-1
8.0 CUSTODIAL MAINTENANCE OR REPAIR	8-1
8.1 Planned maintenance	8-1
8.2 Unscheduled maintenance or repair.....	8-1
8.3 Certification and reporting requirements	8-1
9.0 CORRECTIVE ACTION.....	9-1
9.1 Problem identification	9-1
9.2 Certification and reporting requirements	9-1
10.0 RECORD KEEPING AND REPORTING REQUIREMENTS.....	10-1
10.1 Records	10-1
10.2 Reports	10-3
11.0 EMERGENCY NOTIFICATION AND REPORTING	11-1
11.1 Agency agreements	11-1
11.2 Unusual occurrences	11-1
11.3 Earthquakes	11-1
12.0 QUALITY ASSURANCE	12-1
13.0 PERSONNEL HEALTH AND SAFETY	13-1
13.1 Health and safety	13-1
13.1.1 Unusual hazards and specific safety concerns	13-1
13.1.2 Emergency medical and law enforcement	13-1
13.2 Reportable incidents	13-1

TABLE OF CONTENTS (Concluded)

<u>Section</u>	<u>Page</u>
14.0 REFERENCES	14-1
15.0 LIST OF CONTRIBUTORS	15-1

- ATTACHMENT 1 NRC CONCURRENCE AND LICENSING DOCUMENTATION
- ATTACHMENT 2 SITE OWNERSHIP/CUSTODY DOCUMENTATION
- ATTACHMENT 3 GREEN RIVER PERMANENT SITE FILE INDEX
- ATTACHMENT 4 SITE INSPECTION PHOTO LOG
- ATTACHMENT 5 INITIAL SITE INSPECTION CHECKLIST
- ATTACHMENT 6 AGENCY NOTIFICATION AGREEMENTS

LIST OF FIGURES

Figure	Page
2.1 Green River site location map, Green River, Utah, site	2-2
2.2 Plan view of the Green River disposal cell	2-5
2.3 Diagrammatic cross section of disposal cell and foundation, Green River, Utah, disposal site	2-7
2.4 Disposal cell cover system, Green River, Utah, disposal site	2-8
4.1 Survey monument, Green River, Utah, disposal site	4-2
4.2 Boundary monument, Green River, Utah, disposal site	4-3
4.3 Entrance site marker (SMK 1) at the Green River, Utah, disposal site	4-4
4.4 Site marker (SMK 2) at crest of disposal cell, Green River, Utah, disposal site	4-5
4.5 Site marker incised message-Green River, Utah, disposal site	4-6
4.6 Perimeter sign and message--Green River, Utah, disposal site	4-8
4.7 Entrance sign and message-Green River, Utah, disposal site	4-9
5.1 Location of monitor wells and cross section, Green River, Utah, site	5-2
5.2 Hydrogeologic cross section A-A', Green River, Utah, site	5-3
5.3 Potentiometric surface in the Cedar Mountain Formation, Green River, Utah, site	5-4
9.1 Corrective action-UMTRA Project long-term surveillance program	9-2
9.2 Key elements in the corrective action process	9-3

LIST OF PLATES

Plate 1	Disposal site vicinity map
Plate 2	Disposal site map

LIST OF TABLES

2.1 Green River disposal site access key holders	2-3
3.1 Aerial photography specifications for the Green River disposal site	3-4
5.1 Proposed concentration limits for POC wells, Green River, Utah, site	5-7
5.2 Corrective action plan summary for the Green River, Utah site	5-8

LIST OF ACRONYMS AND ABBREVIATIONS

<u>Acronym</u>	<u>Definition</u>
ac	acre
• C	degrees Celsius
cm	centimeter
D ⁵⁰	median diameter
DOE	U.S. Department of Energy
DQO	data quality objective
EA	environmental assessment
EPA	U.S. Environmental Protection Agency
• F	degrees Fahrenheit
ft	foot
GJO	Grand Junction Office
ha	hectare
in	inch
km	kilometer
LTSP	long-term surveillance plan
m	meter
mm	millimeter
m ³	cubic meter
mi	mile
MCL	maximum concentration limit
mg/L	milligrams per liter
MSL	mean sea level
NRC	U.S. Nuclear Regulatory Commission
NWS	National Weather Service
POC	point of compliance
QA	quality assurance
QC	quality control
RAP	remedial action plan
RRM	residual radioactive material
SOP	standard operating procedure
TDS	total dissolved solids
TEGD	Technical Enforcement Guidance Document
UMTRA	Uranium Mill Tailings Remedial Action
UMTRCA	Uranium Mill Tailings Radiation Control Act
UPDCC	UMTRA Project Document Control Center
USGS	U.S. Geological Survey
WSMR	White Sands Missile Range
yd	yard
yd ³	cubic yard

CHANGE HISTORY

Document version	Date	Pages/comments
Rev. 0, Ver. 1	11/04/93	Initial version.
Rev. 1, Ver. 1	06/16/94	Extensively revised. Response to NRC comments.
Rev. 1, Ver. 2	07/12/94	Extensively revised.
Rev. 1, Ver. 3	07/21/94	Section 5.0 extensively revised.
Rev. 1, Ver. 3	08/03/94	Revised pages 2-3, 5-1, and 5-13. Revised Figure 5.3. Renumbered Tables 5.1 and 5.2, updated callouts and front matter, and reprinted Section 5.0.
Rev. 1, Ver. 4	05/11/98	Revised Section 5.0 to reflect RAP Modification No. 2 changes to ground water compliance strategy and monitoring requirements.
Rev. 2, Ver. 0	07/07/98	Response to NRC comments

1.0 INTRODUCTION

The long-term surveillance plan (LTSP) for the Green River, Utah, Uranium Mill Tailings Remedial Action (UMTRA) Project disposal site describes the surveillance activities for the Green River disposal cell. The U.S. Department of Energy (DOE) will carry out these activities to ensure that the disposal cell continues to function as designed. This final LTSP was prepared as a requirement for acceptance under the U.S. Nuclear Regulatory Commission (NRC) general license for custody and long-term care of residual radioactive materials (RRM). This LTSP documents whether the land and interests are owned by the United States or an Indian tribe and details how the long-term care of the disposal site will be carried out. The Green River, Utah, LTSP is based on the DOE's *Guidance for Implementing the UMTRA Project Long-term Surveillance Program* (DOE, 1992a).

1.1 BACKGROUND

Title I of the *Uranium Mill Tailings Radiation Control Act* (UMTRCA) of 1978 (42 USC §7901 *et seq.*) authorized the DOE to perform remedial action at 24 inactive uranium mill tailings sites to reduce the potential effect on public health from unstabilized RRM in and around the uranium mill tailings. The Green River, Utah, uranium processing site in Grand County was one of the 24 sites identified for remediation in the UMTRCA. Effective May 15, 1980, the DOE and the state of Utah entered into a cooperative agreement under the UMTRCA, establishing the terms and conditions of the remedial action (DOE Cooperative Agreement No. DE-FC04-81AL16309) (DOE, 1991; 1988). Remedial action began in November 1988 and was completed in September 1989. The RRM (tailings) and other contaminated materials at the Green River designated processing site were stabilized on the site in a permanent disposal facility about 600 feet (ft) (180 meters [m]) southeast of the uranium processing site. The NRC has concurred with the DOE's determination that remedial action at the Green River site is complete. Attachment 1 contains NRC concurrence and licensing documentation.

The tailings and other contaminated materials are consolidated in a below-grade area; it contains approximately 382,000 yd³ (291,000 m³) of compacted tailings. The resulting disposal cell is contoured to have 20-percent (5 horizontal to 1 vertical) sideslopes. To ensure compliance with U.S. Environmental Protection Agency (EPA) standards (40 CFR Part 192), the tailings and contaminated materials are covered with 3 ft (0.9 m) of compacted earth (radon/infiltration barrier) to inhibit the emanation of radon and the infiltration of water. The topslope and sideslopes of the disposal cell are covered with a 0.5-ft (0.2-m)-thick layer of sand and gravel and a 1-ft (0.3-m)-thick layer of rock to protect the radon/infiltration barrier from erosion. These layers also protect against penetration by animals and prevent human intrusion.

The stabilized disposal cell covers approximately 5 acres (ac) (2 hectares [ha]) and is approximately 530 by 450 ft (160 by 140 m) along the sides. After remedial action, the area of the existing tailings pile was backfilled, graded to

promote surface drainage, and revegetated. All other areas disturbed at the site by remedial action have been backfilled and graded to promote surface drainage.

1.2 LICENSING PROCESS

The NRC has developed regulations (10 CFR §40.27) issuing a general license for the long-term care of DOE UMTRA Project (Title I) disposal sites, including the Green River disposal site. The license is available only to the DOE (or any successor federal agency designated by the President of the United States) and has no termination date. The purpose of this general license is to ensure that the UMTRA Project disposal sites will be cared for in a manner that protects public health and safety and the environment. The license takes effect at a site after the NRC concurs that remedial action is complete at that site (i.e., accepts the site-specific completion report and certification summary) and formally accepts a site-specific LTSP that meets the requirements of 10 CFR §40.27. The site-specific completion report documents the site as-built conditions. The DOE prepares a certification summary memorandum certifying satisfaction of approved remedial action plan (RAP) provisions and compliance with EPA standards. The DOE compiles the final completion report, final audit report, and certification summary into the certification report and submits it to the NRC for concurrence (DOE, 1993). Because the Green River processing site uranium mill tailings were stabilized on the site, the site will be licensed in two steps: surface remediation and ground water compliance.

The DOE will conduct long-term surveillance activities at the Green River disposal site unless the President of the United States designates another federal agency to perform these activities. The DOE UMTRA Project Office will conduct interim surveillance activities at the disposal site until the NRC issues Phase I of the license. At that time, the long-term surveillance and maintenance activities will be transferred to the DOE Grand Junction Office (GJO).

1.3 ACQUISITION

The state of Utah acquired 103.5 ac (42 ha) of land from Umetco Minerals Corporation. The final disposal site is located within the boundaries of the state-owned land. The fee simple title obtained from Umetco conveys all reservations of oil, gas, and mineral rights owned or leased. The area encompassed by the final site boundaries is 25.27 ac (10.2 ha).

Attachment 2 contains land ownership documentation. It includes two legal land descriptions: the final site boundary, which defines the area transferred to the United States of America, and the boundary of the state-owned land. Both boundaries are labeled on the disposal site map in Plate 1.

The title documentation is included in the Green River permanent site file and in Attachment 2. The DOE, or another federal agency that the President of the United States may designate, has perpetual custody of the Green River disposal site and the permanent right of entry to undertake any monitoring, maintenance,

and emergency measures necessary to protect public health and safety and the environment.

The NRC and the state of Utah concurred with the DOE's RAP (DOE, 1991 and 1998) under the requirements of the final EPA standards in 40 CFR Part 192 (Attachment 1). The remedial actions were described and evaluated in an environmental assessment (EA) (DOE, 1988) prepared by the DOE. Ground water compliance activities (under 40 CFR 192 (Subpart B)) at the processing site will be implemented at a later date.

The NRC has concurred with the completion of surface remedial action (Attachment 1).

1.4 LONG-TERM SURVEILLANCE PLAN

This document describes the long-term surveillance program to be implemented at the Green River disposal site to ensure that the disposal cell continues to perform as designed. The plan is based on the DOE's *Guidance for Implementing the UMTRA Project Long-term Surveillance Program* (DOE, 1992a).

This LTSP meets the requirements of 10 CFR §40.27 by addressing the following:

- Site description and ownership.
- Description of final site conditions.
- Site inspection procedures and personnel.
- Custodial maintenance and corrective action programs.
- Record keeping and reporting.
- Quality assurance monitoring activities.
- Emergency response.

2.0 FINAL SITE CONDITIONS

2.1 SITE HISTORY

The uranium processing mill at the Green River site was built in 1957 by Union Carbide Corporation. The mill operated from March 1958 through January 1961. During that time, the uranium mill processed 183,000 tons (166,018 tonnes) of ore averaging 0.29 percent uranium oxide, producing an ore concentrate that was shipped by railroad to the company's processing plant in Rifle, Colorado (DOE, 1988). Tailings were moved and stabilized within the processing site boundaries.

2.2 FINAL SITE CONDITIONS

2.2.1 Description and location of the disposal site area

The Green River disposal site is located in Grand County, Utah, 1 mile (mi) (1.6 kilometers [km]) southeast of the city of Green River and 0.5 mi (0.8 km) south of U.S. Highway 6&50 (U.S. 6&50) (Figure 2.1). The disposal site is in the Gunnison Valley; this valley is bordered on the north by the Book Cliffs and on the south by the San Rafael Valley. The area contains cliffs, mesas, and the Gray Canyon of the Green River.

The area's climate is arid, with an average annual precipitation of 6.2 inches (160 millimeters [mm]) for the period 1951 through 1980. Average temperatures at the site vary from 23 degrees Fahrenheit ($^{\circ}$ F) (-5 degrees Celsius [$^{\circ}$ C]) in January to 78 $^{\circ}$ F (26 $^{\circ}$ C) in July. Vegetation in the immediate site area consists of species common to the arid desert environment (e.g., greasewood, saltbush, rabbitbrush, Indian ricegrass, and galleta grass). The elevation above mean sea level (MSL) at the site varies from 4064 ft (1239 m) along the northern boundary to 4144 ft (1263 m) along the southern boundary.

A portion of the disposal site is in the 100-year and 500-year floodplains of Brown's Wash, an intermittent tributary of the Green River that flows southward and discharges into the Colorado River 60 air mi (97 km) south of the city of Green River. The disposal site is bordered by a mainline track of the Denver and Rio Grande Western Railroad on the north and Interstate 70 (I-70) on the south. The mill buildings and a water tower were decontaminated and left intact at the uranium processing site. No historical or cultural resources or any threatened and endangered species were affected by the remedial actions at the disposal site.

2.2.2 Disposal site access and security

The route from Green River, Utah, to the access gate at the south end of the site is as follows:

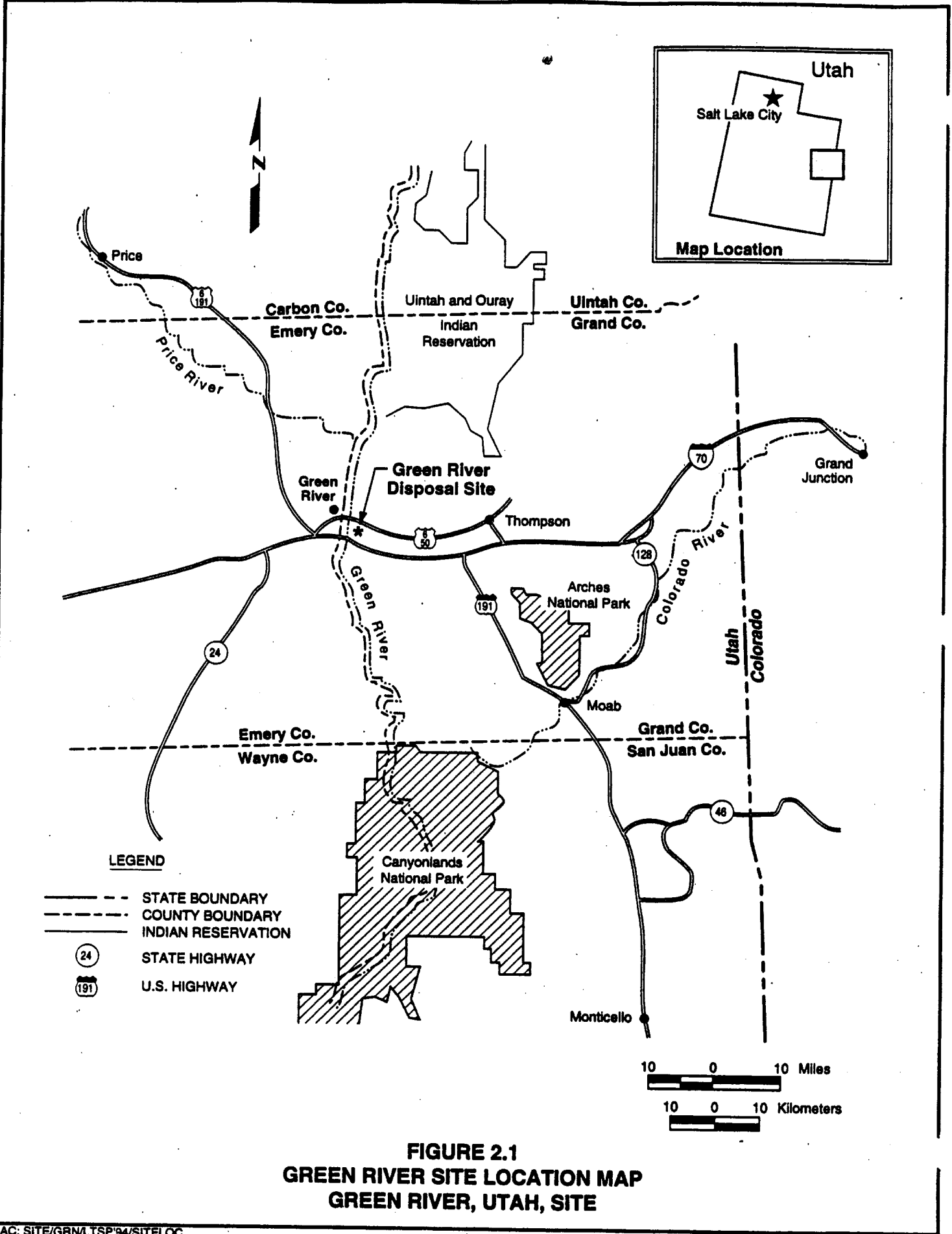

FIGURE 2.1
GREEN RIVER SITE LOCATION MAP
GREEN RIVER, UTAH, SITE

Mileage	Route
0.0	East end of the State Highway 19 bridge spanning the Green River. Proceed east on State Highway 19.
1.0	Highway overpass crosses Brown's Wash.
1.2	Highway overpass crosses Denver and Rio Grande Western Railroad tracks.
1.8	Highway overpass crosses Interstate 70 and U.S. Highways 6 and 191.
1.9	Junction; turn right onto frontage road that heads westward. (Beginning of property owned by DOA.)
2.8	Junction; turn right and proceed through underpass below Interstate 70.
3.0	Turn right off road. (End of property owned by DOA.)

The site was acquired through a land patent from the state. Access to the site is covered under a permit issued by the U.S. Department of the Army (DOA). Attachment 2 contains the recorded data of these acquisitions and the locations of subject files.

Disposal site keys are maintained by the DOE UMTRA Project Manager; the TAC UMTRA Project Manager; and the GJO Supervisory, General Engineer (Table 2.1).

Table 2.1 Green River disposal site access key holders

Title and current contact	Telephone	Address
DOE UMTRA Project Manager	(505) 845-4022	U.S. Department of Energy Albuquerque Operations Office ERD/UMTRA P.O. Box 5400 Albuquerque, NM 87185-5400
TAC UMTRA Project Manager	(505) 888-1300	Jacobs Engineering Group 2155 Louisiana NE Suite 10,000 Albuquerque, NM 87111
Supervisory, General Engineer, GJO	(970) 248-6006	2597 B 3/4 Road Grand Junction, CO 81503

The state of Utah maintains a fence surrounding an area that includes the disposal site. In addition, there is a woven wire security fence around the disposal cell.

2.2.3 Disposal cell design

The stabilized disposal cell was constructed primarily below the existing ground surface; it contains 382,000 yd³ (291,000 m³) of compacted tailings. The dimensions of the disposal cell are approximately 530 ft (160 m) by 450 ft (140 m), including the 20-ft (6-m)-wide toe apron (Figure 2.2).

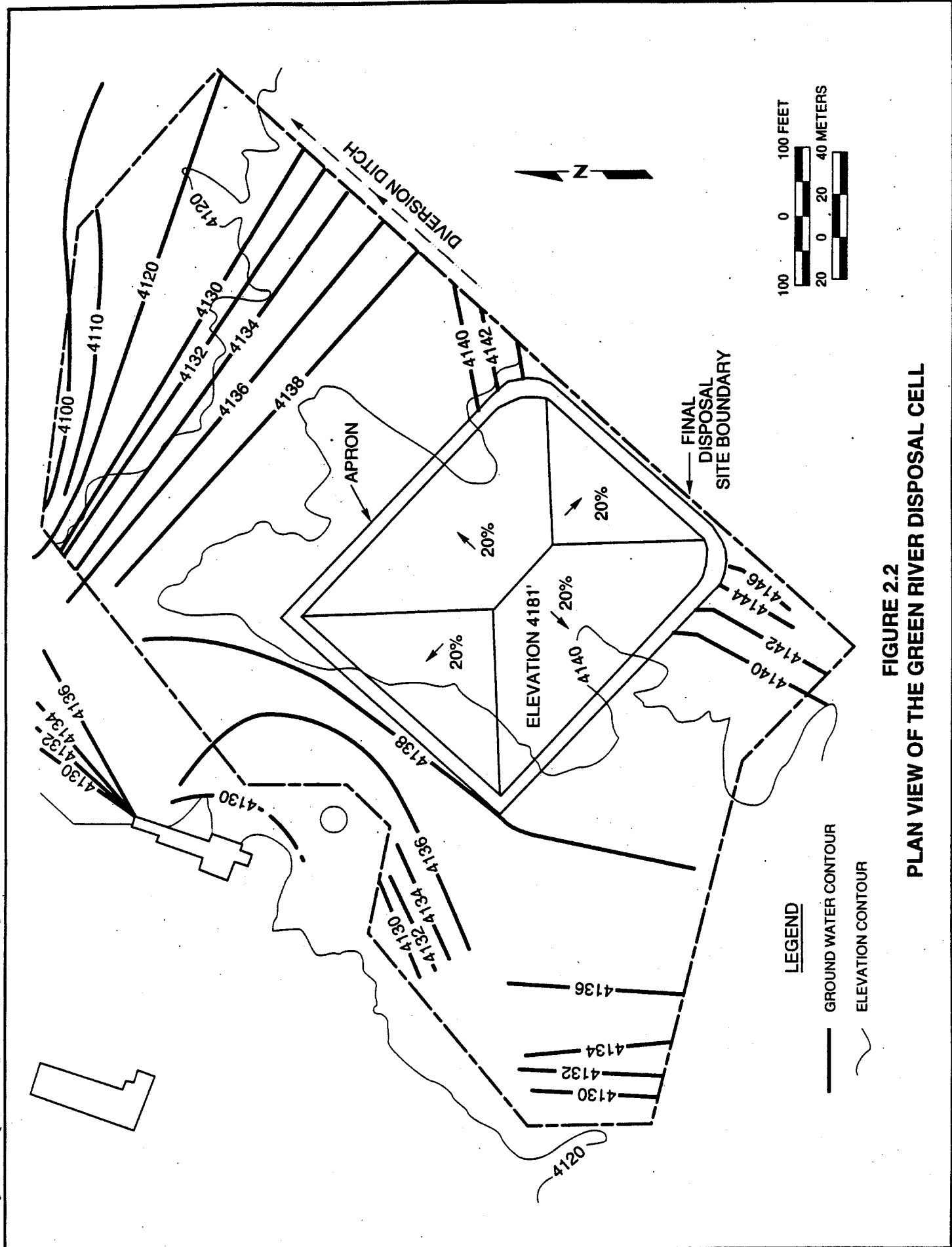

**FIGURE 2.2
PLAN VIEW OF THE GREEN RIVER DISPOSAL CELL**

Contaminated materials were placed on a 6-ft (2-m)-thick layer of compacted clean fill, then covered with a silty clay material (radon/infiltration barrier). The disposal cell was capped with large-diameter rock that prevents wind and water erosion of the radon/infiltration barrier and underlying contaminated material. Slopes of the disposal cell are 5 horizontal to 1 vertical (20 percent), and the maximum elevation of the cell is 4181 ft (1274 m) above MSL.

The location of the disposal cell was selected for protection against erosion from Brown's Wash and undercutting of the disposal cell by gully formation. The excavation for the below-grade portion of the disposal cell extended into bedrock of the Dakota and Cedar Mountain Formations (maximum depth of 43 ft [13 m]). Contaminated material was placed and compacted on top of a 6-ft (2-m)-thick layer of select fill at the bottom of the excavation (Figure 2.3).

The infiltration/radon barrier was covered by an erosion protection layer designed to protect the disposal cell from runoff, flooding, and the encroachment of gullies. The uppermost portion of the erosion protection layer is a layer of Type A riprap 12 inches (300 mm) thick (Figures 2.3 and 2.4). The median diameter (D_{50}) rock size for Type A riprap is 2 inches (50 mm). A 6-inch (150-mm)-thick bedding layer was placed between the riprap and the infiltration/radon barrier to prevent migration of the infiltration/radon barrier into the riprap. A buried apron consisting of Type B riprap a minimum of 36 inches (910 mm) thick was placed below grade around the toe of the cell. The D_{50} rock size for Type B riprap is 18 inches (460 mm). A 12-inch (300-mm)-thick layer of Type A riprap and a 6-inch (150-mm)-thick layer of bedding material was constructed between the infiltration/radon barrier and Type B riprap to prevent migration of the infiltration/radon barrier material into the Type B riprap (Figure 2.3). Riprap toe protection extends about 20 ft (6 m) on the surface from the disposal cell toe to reduce erosion of the ground surface adjacent to the disposal cell. Existing gullies near the disposal cell were regraded and filled to minimize erosion potential and the formation of new gullies.

The 36-in (910-mm)-thick infiltration/radon barrier was placed over the contaminated materials. This barrier was constructed of compacted silty clay and was designed to 1) protect ground water by minimizing infiltration, and 2) reduce radon flux from the disposal cell to less than 20 picocuries per square meter per second. Six percent bentonite by weight was mixed into the radon barrier material to ensure that the compacted infiltration/radon barrier has a saturated hydraulic conductivity of less than 2×10^{-8} centimeters per second. Twenty-one inches (530 mm) of the infiltration/radon barrier are below the maximum projected frost depth of 39 inches (990 mm) (DOE, 1991) at the toe of the sideslopes.

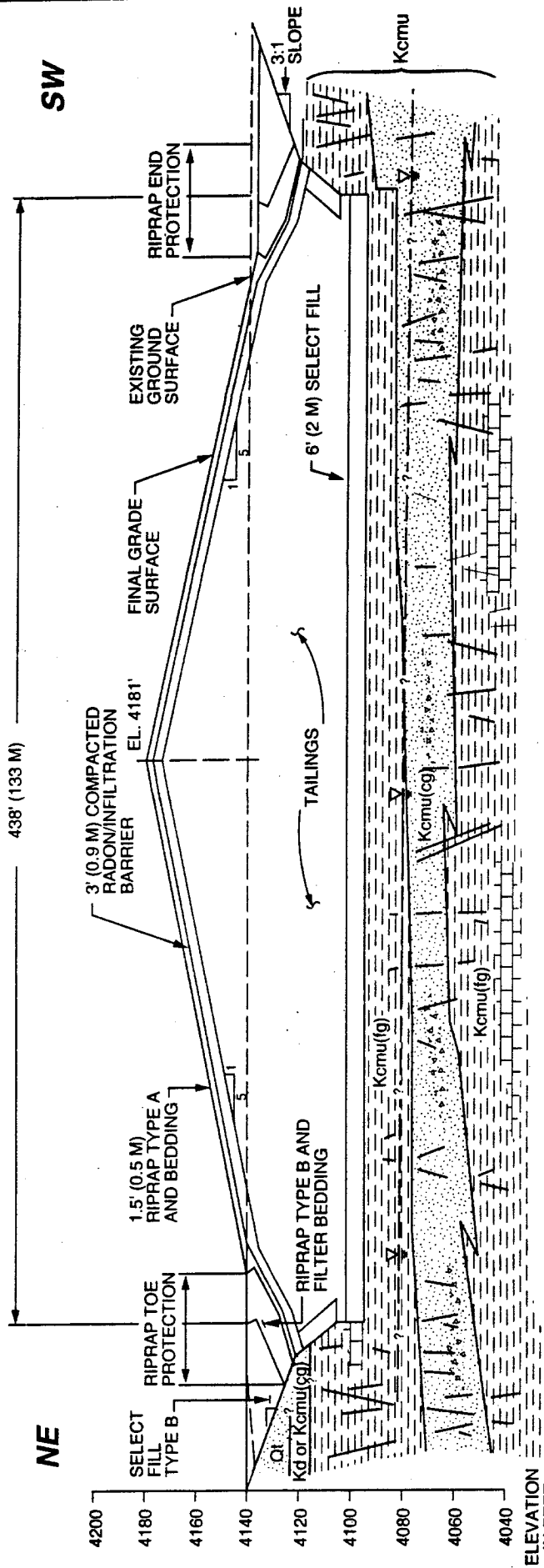

REF: DOE, 1991

LEGEND

FORMATION	MATERIAL	ROCK TYPE
Qt	TERRACE ALLUVIUM	SOILS
Kd	DAKOTA SANDSTONE	
Kcmu(fg)	CEDAR MOUNTAIN FORMATION - UNNAMED MEMBER (FINE-GRAINED MIDDLE HYDROSTRATIGRAPHIC UNIT)	SANDSTONE OR SILTSTONE
Kcmu(cg)	CEDAR MOUNTAIN FORMATION - UNNAMED MEMBER (COARSE-GRAINED MIDDLE HYDROSTRATIGRAPHIC UNIT)	SHALE OR MUDSTONE
		LIMESTONE
		CONGLOMERATE
	FRACTURES	
	POTENTIOMETRIC SURFACE	

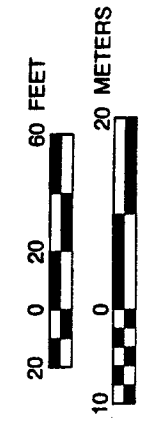
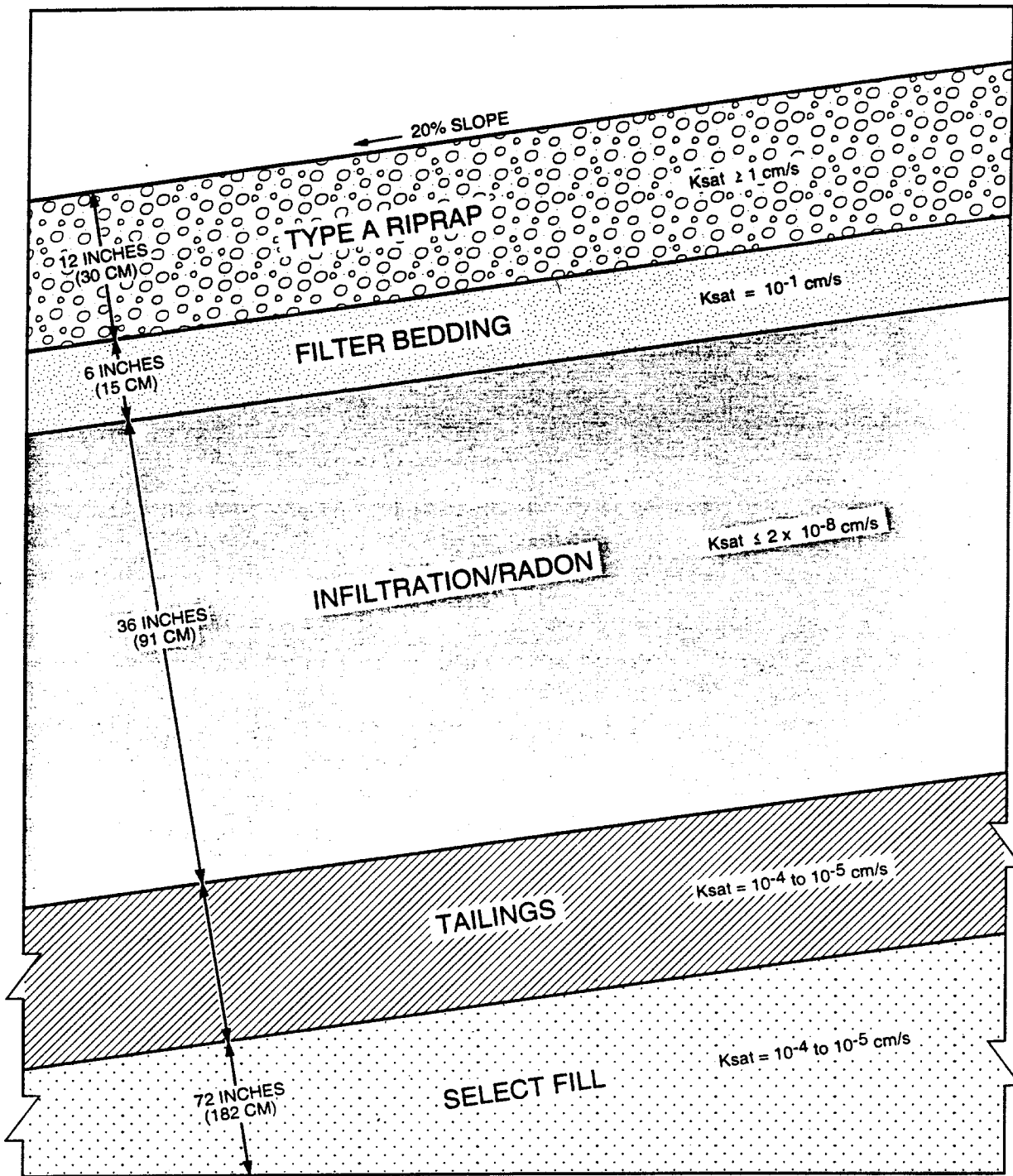

FIGURE 2.3
DIAGRAMMATIC CROSS SECTION OF DISPOSAL CELL AND FOUNDATION
GREEN RIVER, UTAH, DISPOSAL SITE



SCHEMATIC - NOT TO SCALE

LEGEND

K_{sat} SATURATED HYDRAULIC CONDUCTIVITY
 cm/s CENTIMETERS PER SECOND

**FIGURE 2.4
 DISPOSAL CELL COVER SYSTEM
 GREEN RIVER, UTAH, DISPOSAL SITE**

The specifications for placement of materials were prepared to minimize and control the use of water. The 20-percent slopes, in conjunction with the filter bedding layer, will cause most excess surface water to run off the disposal cell, thus minimizing the potential for precipitation to infiltrate into contaminated material.

The surface conditions of the disposal cell will be monitored during annual inspections to determine whether the disposal cell and erosion protection measures are performing as designed. Guidelines to be followed when inspecting the disposal cell and criteria for corrective actions or repairs are as follows:

- **Crest** - Observations will be made in all directions of any features that are anomalous or unexpected and that may require a closer inspection. Inspectors will walk around the edge and along diagonal transects of the crest. Additional transects, at approximate 50-yard (yd) (46-m) intervals, will be walked along the sideslopes. The inspectors will search for evidence of any differential settling, subsidence, or cracks. The rock cover will be examined for evidence of rapid deterioration. Individual rocks will be examined for excessive fracturing, oxidation, or other signs of deterioration. The inspectors will also note whether rock and other cover material has been removed or displaced.
- **Gullies, rills, ditches, swales** - The inspectors will walk along the entire length of any ditches or man-made swale in the immediate vicinity of the disposal site to determine whether the channels have been functioning, and can be expected to continue to function, as designed. The channels and sideslopes of ditches and swales will be examined for evidence of erosion or sedimentation, slides, or incipient erosion channels, debris, growing vegetation, or burrowing animals.

The designated disposal site and the area surrounding the site will be surveyed carefully to determine whether deep or severe gullies and widespread rills are developing.

Measures for initiating corrective action or repair to engineering features at the Green River disposal site are as follows:

- Erosion of, or gully or rill formation in, underlying cover layers caused by missing or displaced riprap.
- Obvious deterioration of erosion protection rock (for example, fragmentation of large-diameter rock).
- Development of rills on the designated disposal site. The severity of the problem will be determined by the soil type (where rills are reported) and the size of the area affected.

- Development of gullies within the disposal site boundary or adjacent to site boundaries that could warrant concern, based on the inspectors' professional judgment.
- Undercutting of the soil around the disposal cell toe apron.

3.0 SITE DRAWINGS AND PHOTOGRAPHS

At the completion of remedial action, disposal site as-built conditions were documented with as-built drawings, baseline photographs, and aerial photographs (MK-F, 1991). This information will be used to illustrate baseline conditions against which future conditions at the disposal site can be compared. Photographs taken during site inspections will provide continuing documentation of changing conditions at the disposal site.

3.1 DISPOSAL SITE MAP AND DRAWINGS

A site atlas has been prepared that includes a disposal site vicinity map and a disposal site map (Plates 1 and 2). This site atlas will be updated, as necessary, after each site inspection. All drawings, maps, and photographs will be archived in the UMTRA Project Document Control Center (UPDCC). These maps, drawings, and photographs may be further modified by the GJO, as necessary, and the GJO will be responsible for maintaining and archiving these maps, drawings, and photographs after the Green River permanent site file is transferred to the GJO. An index of the Green River permanent site file is provided in Attachment 3.

3.1.1 Disposal site vicinity map

The disposal site vicinity map (Plate 1) encompasses a 3.0-mi (4.8-km) radius and includes the following information:

- The scale (1 inch equals 1000 ft).
- County boundaries.
- Disposal site boundary and state-owned legal boundary.
- Longitude and latitude and state plane coordinates; section, township, range.
- Primary drainage systems (Green River and Brown's Wash).
- Roads and buildings.

The disposal site vicinity map will be updated, as necessary, after each scheduled site inspection. The new map will include the revision number and the year of revision. All site maps and periodic site inspection maps will become part of the Green River permanent site file.

3.1.2 Disposal site map

The Green River disposal site map, including topographic features for the Green River disposal site, is included as Plate 2. The map identifies the following site features:

- The scale (1 inch equals 200 ft).
- The disposal site and an area of 0.25 mi (0.40 km) around the site perimeter.

- The contour interval (10 ft).
- The disposal site property boundary, fences, gates, and access roads.
- The outline of the toe base and crest of the disposal cell.
- Immediately adjacent geomorphic features that represent dynamic processes (Green River and Brown's Wash).
- Disposal site monitor wells.
- Other ground water monitor wells and access roads to them.
- Surveying control point.
- Permanent site surveillance features (e.g., monuments, markers, signs, and water tower).
- Site coordinate system.

When the disposal site map is updated, the revised map will include the year of revision and the revision number.

The Green River disposal site map will serve as the base map for the site inspection map. A new, separate inspection map will be prepared after each inspection. Each site inspection map will indicate the year of the inspection and the type of inspection. All site maps and site inspection maps will become part of the Green River permanent site file.

3.1.3 Disposal site as-built drawings

After remedial action was completed at the Green River disposal site, as-built drawings were made to illustrate the final disposal cell construction and final disposal site conditions. These drawings were used to prepare the disposal site map and will be stored in the Green River permanent site file. These drawings will be used to document changes in physical site conditions or changes to the disposal cell over time for developing corrective action plans, if required.

3.2 SITE BASELINE PHOTOGRAPHS

Two sets of baseline photographs will be placed in the Green River permanent site file. One set of photographs was taken during the remedial action to illustrate implementation of the final design and site construction methods. These photographs may provide useful construction details if corrective action or repairs become necessary. The other set of baseline photographs was taken at the end of construction to document as-built conditions.

3.3 SITE AERIAL PHOTOGRAPHS

After construction activities were completed at the disposal site, aerial photographs were taken in the spring of 1990. These photographs were used to prepare the topographic map and provide a permanent record of as-built site conditions. These aerial photographs are useful as a baseline for comparing any changes in site conditions over time. The need for new aerial photographs will be assessed at regular 5-year intervals, unless unusual conditions require more frequent assessment. Unless site conditions require otherwise, the area photographed will include the disposal site and the area 0.25 mi (0.40 km) outside the site boundary. A summary of specifications for aerial photographs at the Green River disposal site is provided in Table 3.1. More detailed guidance is provided in the *Guidance for Implementing the UMTRA Project Long-term Surveillance Program* (DOE, 1992a).

3.4 SITE INSPECTION PHOTOGRAPHS

Photographs will be taken during site inspections to document conditions of the disposal cell and disposal site. The photographs will provide a continuous record for monitoring changing conditions over time. They can be compared with the baseline photographs to determine whether the integrity of the site has been affected. Those features for which photographic documentation would be routinely required will be determined in conjunction with the preparation of the site inspection checklist.

Each photograph will be recorded individually on the photo log form (Attachment 4). An appropriate description of the feature photographed, including the azimuth (if necessary), will be entered on the log form. Copies of the photographs and the photo logs will be included in annual inspection reports.

Whenever possible, a photograph should include a reference point such as a survey monument, boundary monument, site marker, or monitor well. For large-scale features such as drainage ditches or disposal cell slopes, a north arrow and a scale will be included for reference.

For specific areas where the photograph is used to monitor changes over time, the distance from the feature and the azimuth will be recorded. All subsequent photographs will be taken from the same orientation to provide a more accurate picture of changing conditions. The magnetic declination of the compass should be corrected for true north. This information will also be provided on the site inspection checklist and photo log.

Table 3.1 Aerial photography specifications for the Green River disposal site

Area to be photographed	Final disposal site plus a minimum of 0.25 mi (0.40 km) beyond site boundaries unless site conditions require otherwise.
Products to be delivered	One set of vertical color, infrared stereo contact prints, 9-inch (230 mm), scale 1 inch = 200 ft (1 mm = 240 m); double weight, glossy, not trimmed. One index map, scale 1 inch = 200 ft (1 mm = 240 m); flight lines and frame numbers will be provided. One set of two each of low and high oblique photographs (and negatives) in natural color, 8- x 10-inch (200- x 250-mm); or 9- x 9-inch (230- x 230-mm) contact prints.
Flight date	To be determined upon the acceptance of this LTSP.
Camera	Precision, 9- x 9-inch (230- x 230-mm) format for vertical photos. A 35-millimeter (single lens reflex) or larger format camera for oblique photos is acceptable.
Film	Eastman-Kodak Aerochrome Infrared 2443, or its equivalent, for vertical photos. Eastman-Kodak Ektacolor, or its equivalent, for oblique photos.
Filter	Wratten Nos. 12 or 15 for infrared photos. Skylight filter for color photos.
Flight line coverage	60 percent end overlap; 30 percent average side overlap.
Ground control	Control stations will be second order, Class 1, for horizontal control and third order for vertical control (standard U.S. Geological Survey map accuracy specifications).

All site inspection photographs taken and all corresponding photo log forms will be maintained in the Green River permanent site file.

Features to be photographed

The following disposal site features should be documented with photographs during every scheduled inspection at the Green River disposal site:

- Permanent site surveillance features.
- Disposal cell crest lines - both along the crest and at right angles to the crest.
- The disposal cell (top, sides, apron, and surrounding areas). Sufficient photographs should be taken to record the cell's condition. Panoramic sequences of photographs from selected vantage points may be used for this purpose.
- Off-site features that may affect the site in the future.
- Diversion channels or other drainage features.
- Vegetation.
- Areas of eolian sedimentation or erosion.
- Erosion north of the water tower.
- Rill erosion on the northern hillslope.
- Erosion near the southern perimeter signs.

Any new or potential problem areas identified during a site inspection will be well documented with photographs. Photographs will also be taken to provide a record of developing trends and to allow inspectors to make reasonable decisions concerning additional inspections, custodial maintenance or repairs, or corrective actions.

4.0 PERMANENT SITE SURVEILLANCE FEATURES

Survey and boundary monuments, site markers, and entrance and perimeter signs will be the permanent surveillance and maintenance features at the Green River disposal site. Eight boundary monuments and three survey monuments define the 11 corners of the legal boundaries of the irregularly shaped permanent disposal site. Eighteen perimeter (warning) signs were placed at spaced intervals around the disposal site so that one or more signs will be visible in daylight to a person approaching from any direction. One of the perimeter signs and one site marker were placed at the official entrance to the disposal site at the southernmost corner. The other site marker was placed near the center of the crest of the disposal cell.

The construction and emplacement of the site surveillance features are described below and are in accordance with the specifications delineated in the DOE's *Guidance for Implementing the UMTRA Project Long-term Surveillance Program* (DOE, 1992a).

4.1 SURVEY MONUMENTS

The three survey monuments (Figure 4.1), Berntsen RT-1 metal markers, were set into the top of a truncated cone of reinforced (precast) concrete that was set in concrete with the dimensions shown in Figure 4.1. The depth of the hole is a minimum of 18 inches (460 mm) below frost line, for a total depth of 57 inches (1400 mm), or to bedrock. Four reinforcing bars will allow a monument to be easily located with a metal detector should the monument become buried.

The survey monuments establish permanent horizontal control based on the project grid system and are referenced to the U.S. Geological Survey (USGS) triangulation station (station name: Boyd). The station is about 2 mi (3 km) east of Green River at the Green River Test Complex on White Sands Missile Range property.

4.2 BOUNDARY MONUMENTS

Berntsen federal aluminum survey monuments, Model A-1, were used for the eight boundary monuments (Figure 4.2). Ceramic magnets epoxied in the cap and base are vertically oriented so that the monuments can be found easily with a metal detector if they become covered. The monuments are 4 ft (1.2 m) long and extend at least 10 inches (250 mm) above ground surface (Figure 4.2).

4.3 SITE MARKERS

Two unpolished granite site markers constructed with the dimensions shown in Figures 4.3 and 4.4 identify the Green River disposal site, the general location of the stabilized disposal cell (tailings), the date of closure (September 15, 1989), the dry tonnage of tailings (501,000), and the curies of radioactivity (30 curies of radium-226) (Figure 4.5).

BERNTSEN RT - 1 MARKER

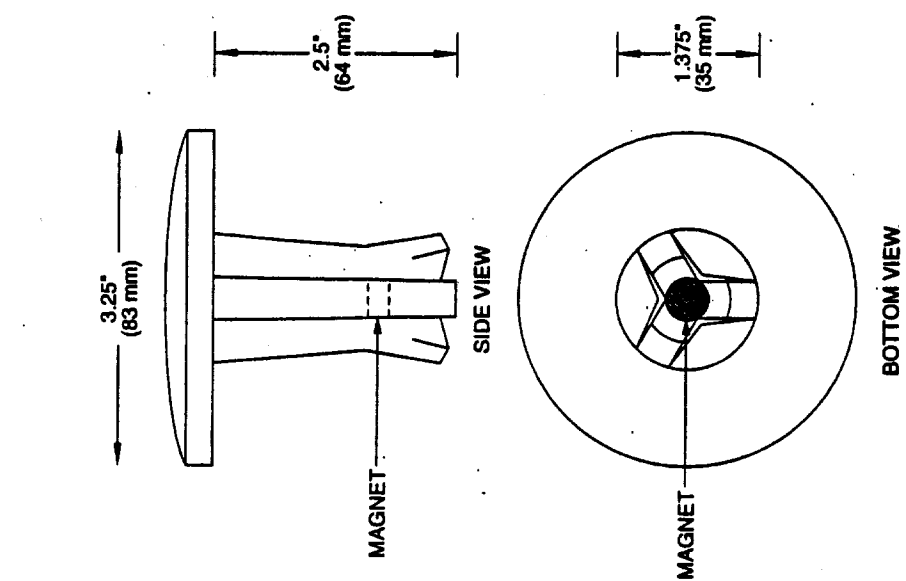

SCHEMATIC - NOT TO SCALE

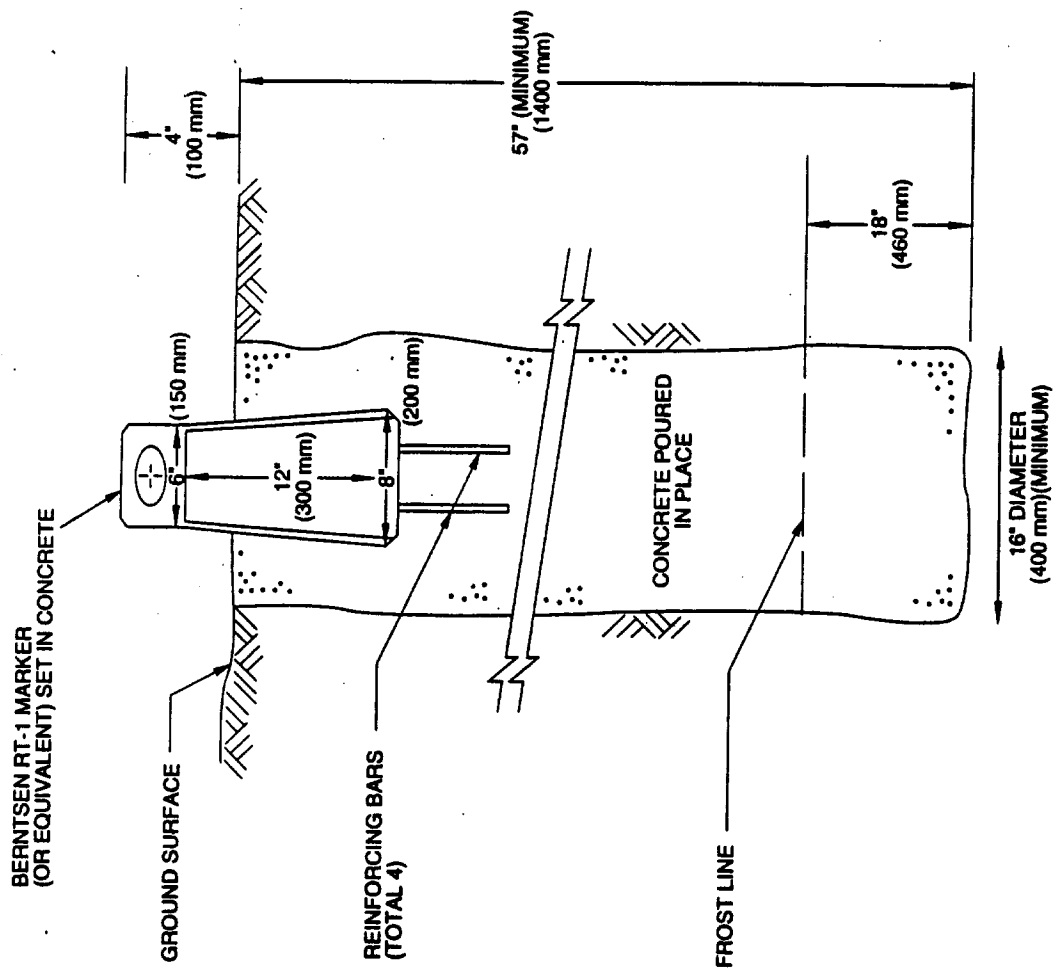

SCHEMATIC - NOT TO SCALE

FIGURE 4.1
SURVEY MONUMENT
GREEN RIVER, UTAH, DISPOSAL SITE

BERNTSEN FEDERAL ALUMINUM SURVEY MONUMENT, MODEL A-1, STANDARD LOGO CAP

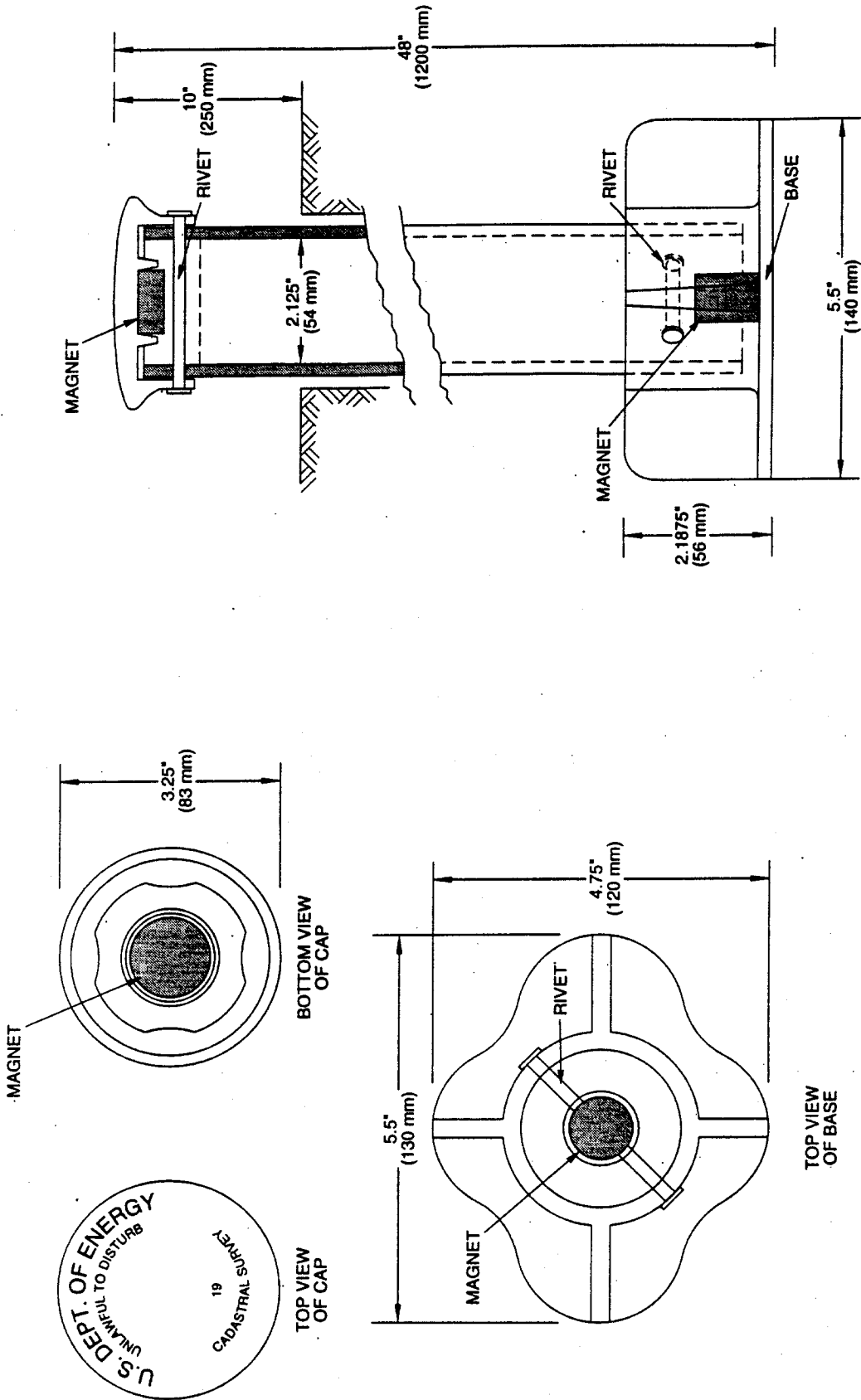

SCHEMATIC - NOT TO SCALE

FIGURE 4.2
BOUNDARY MONUMENT
GREEN RIVER, UTAH, DISPOSAL SITE

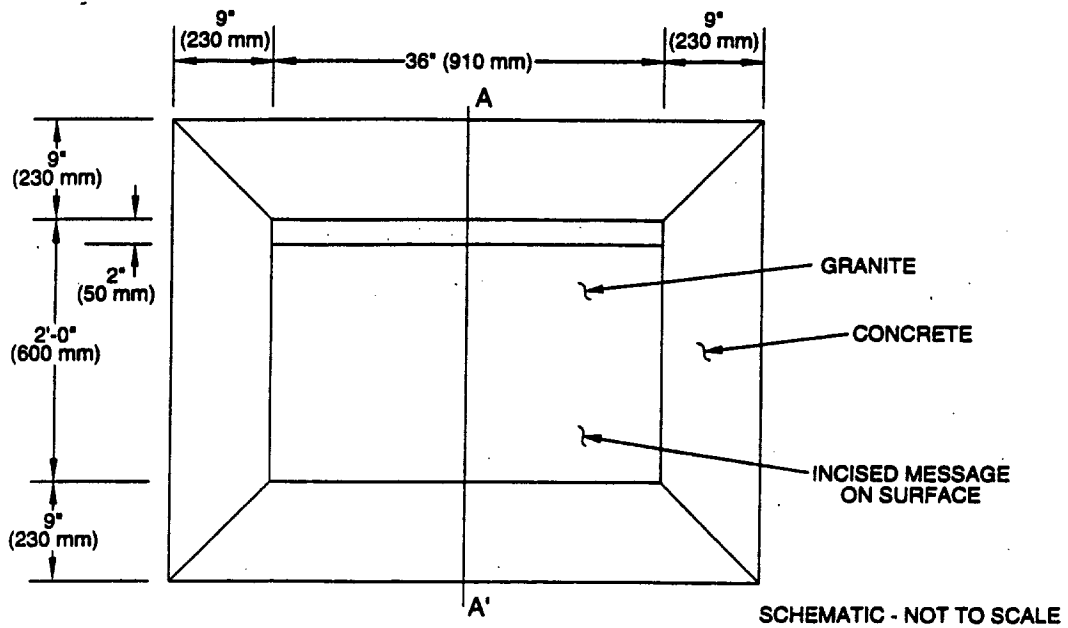

PLAN VIEW (SECTION A-A')

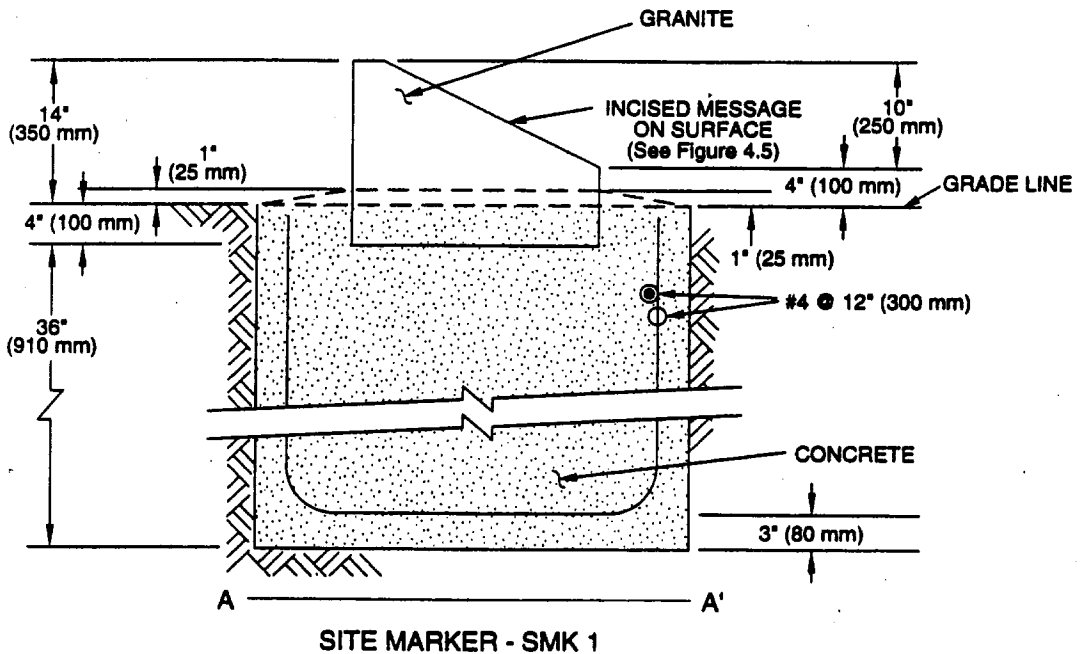
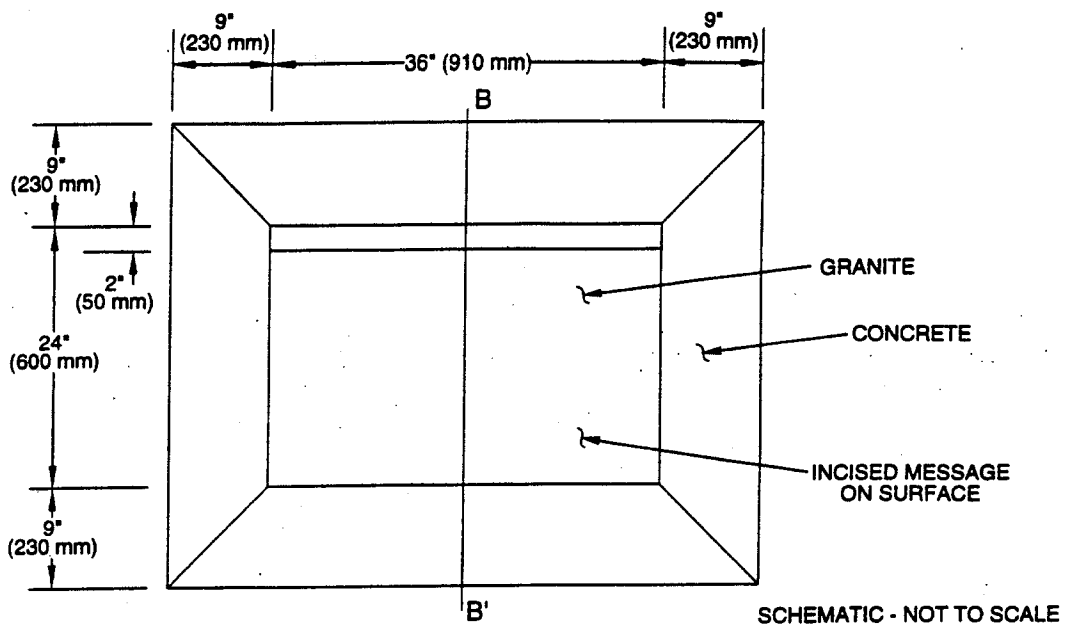
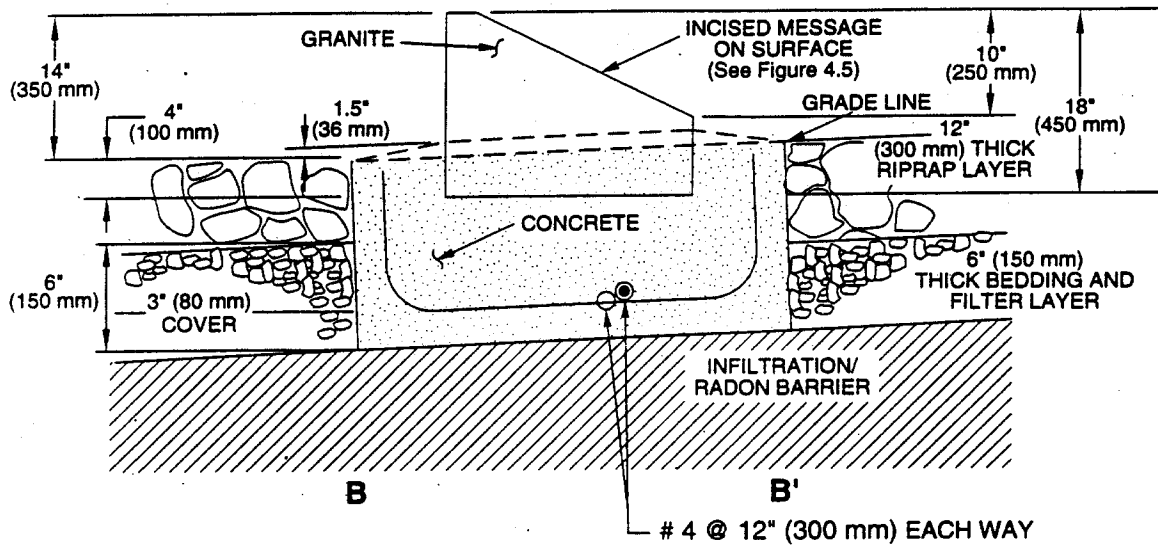

FIGURE 4.3
ENTRANCE SITE MARKER (SMK 1)
AT THE GREEN RIVER, UTAH, DISPOSAL SITE



PLAN VIEW (SECTION B-B')



SITE MARKER - SMK 2

SCHEMATIC - NOT TO SCALE

SIDE VIEW

FIGURE 4.4
SITE MARKER (SMK 2) AT CREST OF DISPOSAL CELL
GREEN RIVER, UTAH, DISPOSAL SITE

GREEN RIVER, UTAH

DATE OF CLOSURE: SEPTEMBER 15, 1989
DRY TONS OF TAILINGS: 501,000
RADIOACTIVITY: 30 CURIES, RA-226

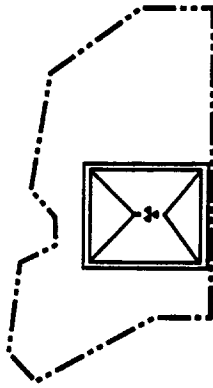

NOTE: MINIMUM DEPTH OF
INCISING TO BE 0.25"
(6.4 mm)

INCISED MESSAGE

FIGURE 4.5
SITE MARKER INCISED MESSAGE
GREEN RIVER, UTAH, DISPOSAL SITE

Site marker SMK-1 near the site entrance (Figure 4.3) was set in a bed of reinforced concrete that extends 3 ft (1 m) below ground surface. Site marker SMK-2 at the crest of the disposal cell (Figure 4.4) was set in a bed of reinforced concrete that extends to the top of the radon barrier. Site marker SMK-2 was excavated and set carefully to minimize disturbance of the surrounding riprap and underlying material.

4.4 ENTRANCE AND PERIMETER SIGNS

Eighteen perimeter signs mounted on steel posts were placed at intervals around the site. These signs display the international symbol indicating the presence of radioactive materials. They also state that the disposal site is government property, that it contains uranium mill tailings, and that trespassing is forbidden (Figure 4.6). The perimeter sign at the site entrance (Figure 4.7) also displays the name of the site and the names and telephone numbers of the DOE and the state of Utah Department of Health, Bureau of Radiation Control. The sign will require updating whenever these telephone numbers change.

The signs were constructed according to the dimensions and specifications shown in Figures 4.6 and 4.7. The tops of the signs are 70 inches (180 mm) above ground surface; the posts were embedded a minimum of 38 inches (970 mm) below ground surface into a concrete footing (minimum 1 ft [0.3 m] diameter).

4.5 SETTLEMENT PLATES

The total long-term settlement of material in the disposal cell is expected to be very small because the materials were compacted during placement. Settlement of the bedrock foundation will be negligible. Therefore, the potential hazards of settlement, including differential settlement-induced cracking of the infiltration/radon barrier, are considered acceptably small, and settlement plates are not required.

4.6 ADDITIONAL SITE SURVEILLANCE FEATURES

Because the main channel of Brown's Wash is not expected to migrate toward the disposal cell, and all existing gullies in the vicinity of the site were filled and graded, additional site surveillance features such as erosion control markers are not required. Where erosion, channel migration, slope retreat, or other slope-modifying processes are active, appropriate measurements, photographs, and notes should be taken to establish the approximate rate and extent of erosion or slope failure.

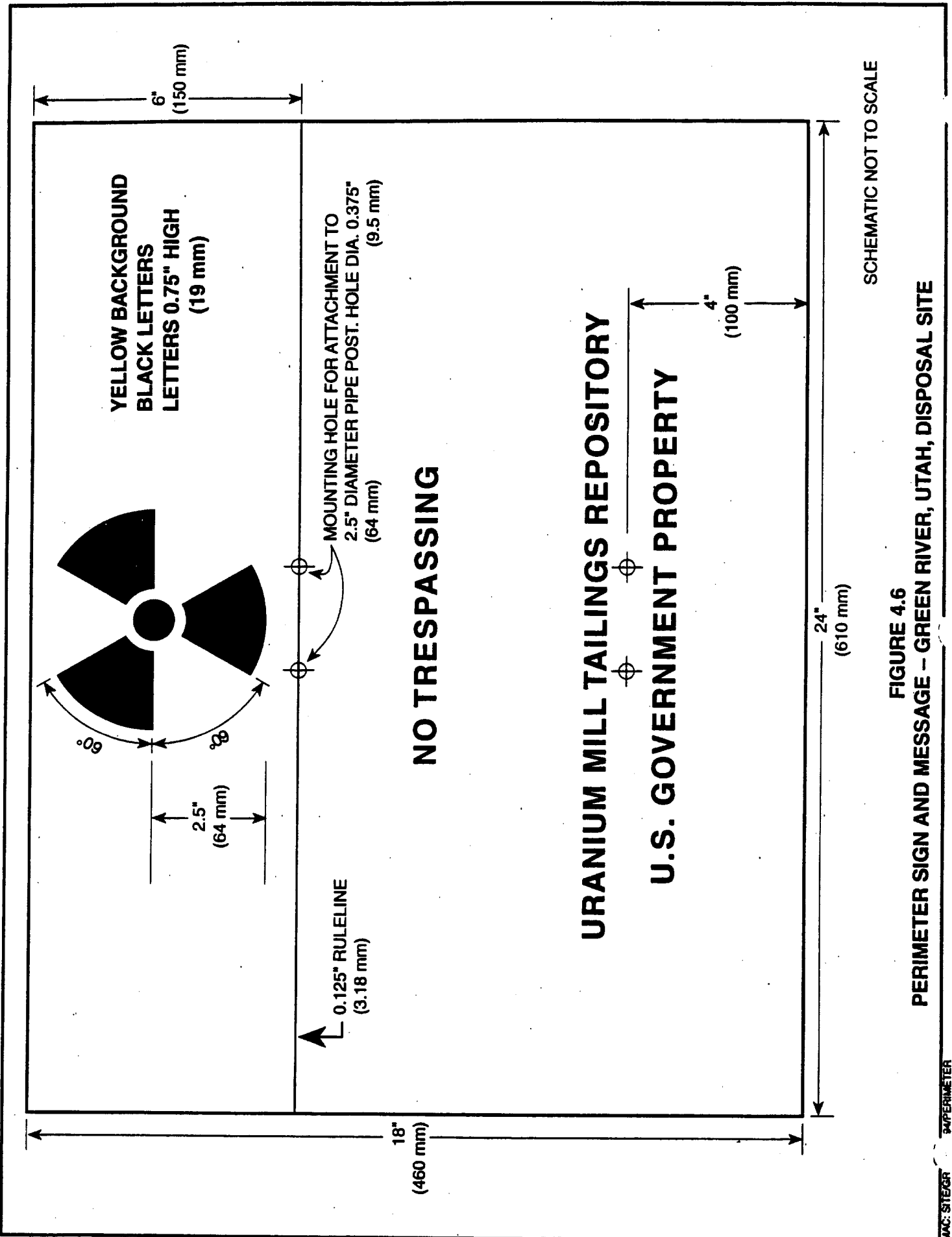

FIGURE 4.6
PERIMETER SIGN AND MESSAGE - GREEN RIVER, UTAH, DISPOSAL SITE

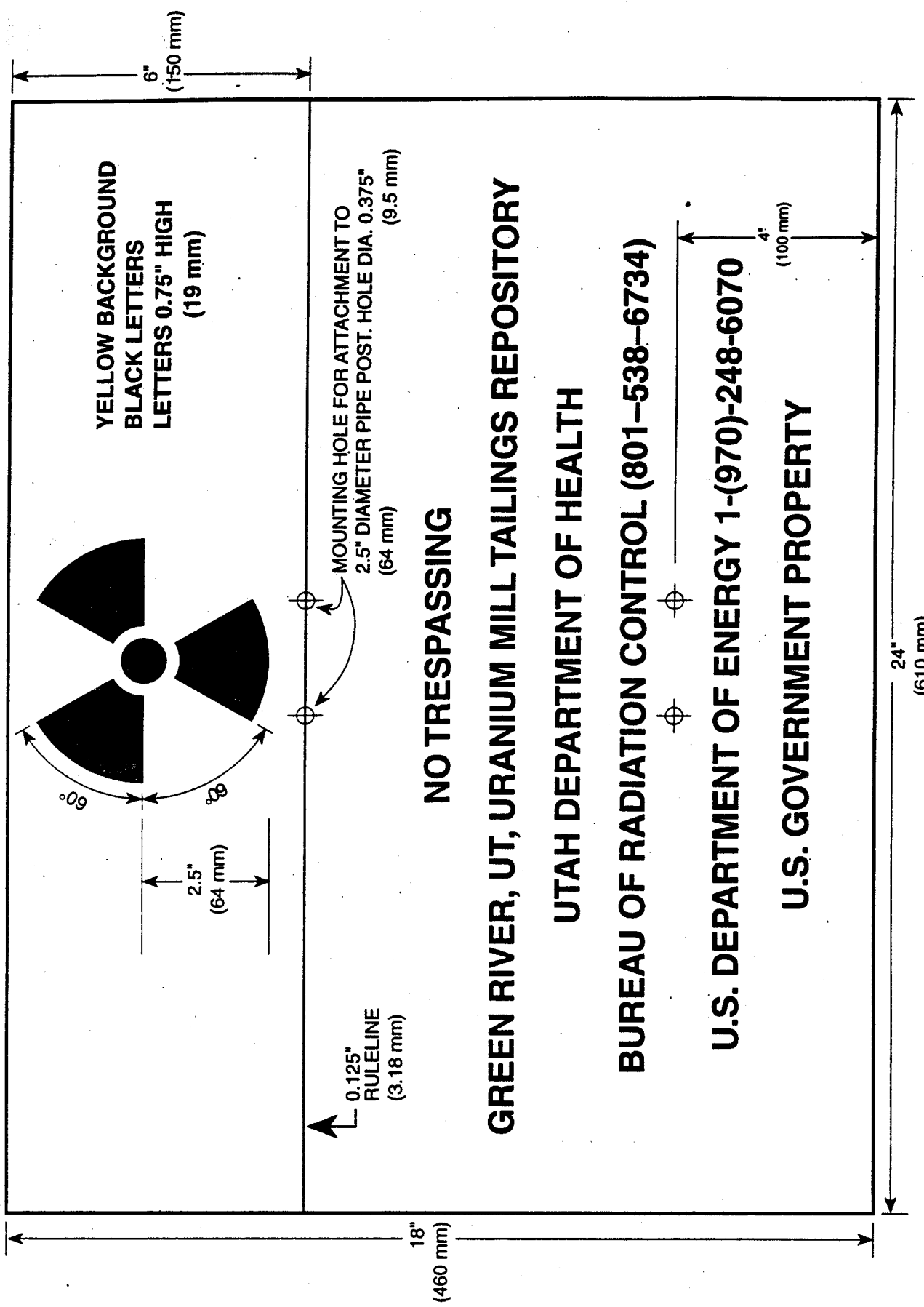

FIGURE 4.7
ENTRANCE SIGN AND MESSAGE - GREEN RIVER, UTAH, DISPOSAL SITE

4.7 REFERENCE POSTS

Because permanent features are unobstructed, reference posts were not required at this site and therefore were not installed.

5.0 GROUND WATER MONITORING

5.1 GROUND WATER CHARACTERIZATION

The DOE has characterized the hydrogeologic units, aquifer hydraulic and transport properties, tailings materials, and geochemical conditions at the Green River disposal site. This information is summarized below, with details provided in the RAP (DOE, 1991), and Modification No. 2 to the RAP (DOE, 1998).

5.1.1 Hydrogeologic setting

Three distinct hydrostratigraphic units are defined beneath the Green River site within 200 ft (60 m) of the ground surface (Figures 5.1 and 5.2). In descending order these units are the Quaternary alluvial deposits along Brown's Wash, the unnamed upper member of the Cretaceous Cedar Mountain Formation, and the underlying Buckhorn Member of the same formation. These units are described as follows:

- The Brown's Wash alluvium is the top hydrostratigraphic unit and consists of a mixture of silt, sand, gravel, and some small cobbles. Ground water in this unit is locally perched by the dense, well-cemented sandstone conglomerate of the Dakota Sandstone and the shale and limestone of the Cedar Mountain Formation (where these bedrock units are not fractured). Directly beneath the former tailings pile, a paleochannel of Brown's Wash has eroded away the Dakota Sandstone, and the Brown's Wash alluvium directly overlies shale of the Cedar Mountain Formation.
- The unnamed member of the Cedar Mountain Formation is the middle hydrostratigraphic unit. This unit consists primarily of complexly interbedded sandstone, siltstone, claystone, shale, and limestone. The sandstone/siltstone/conglomerate facies is referred to as the coarse-grained middle unit and the limestone/shale facies is referred to as the fine-grained middle unit. The unnamed member ranges in thickness from 130 to 160 ft (40 to 50 m). Ground water occurs under confined and semiconfined conditions primarily in a sandstone/siltstone/conglomerate zone of limited areal extent that is bounded above and below by finer-grained materials (limestone/shale). This zone has an approximate maximum thickness of 40 ft (12 m) in the disposal site area. Depth to ground water in this zone is approximately 60 ft (20 m) beneath the ground surface. Ground water in this unit generally flows to the northwest (Figure 5.3).
- The Buckhorn Member of the Cedar Mountain Formation is the bottom hydrostratigraphic unit. This unit consists primarily of sandstone with minor interbeds of mudstone and shale. The top of this unit is encountered at approximately 160 ft (50 m) beneath the ground surface. The thickness of this unit is not determined in this area. Jurassic-age sedimentary rocks lie beneath the bottom hydrostratigraphic unit.

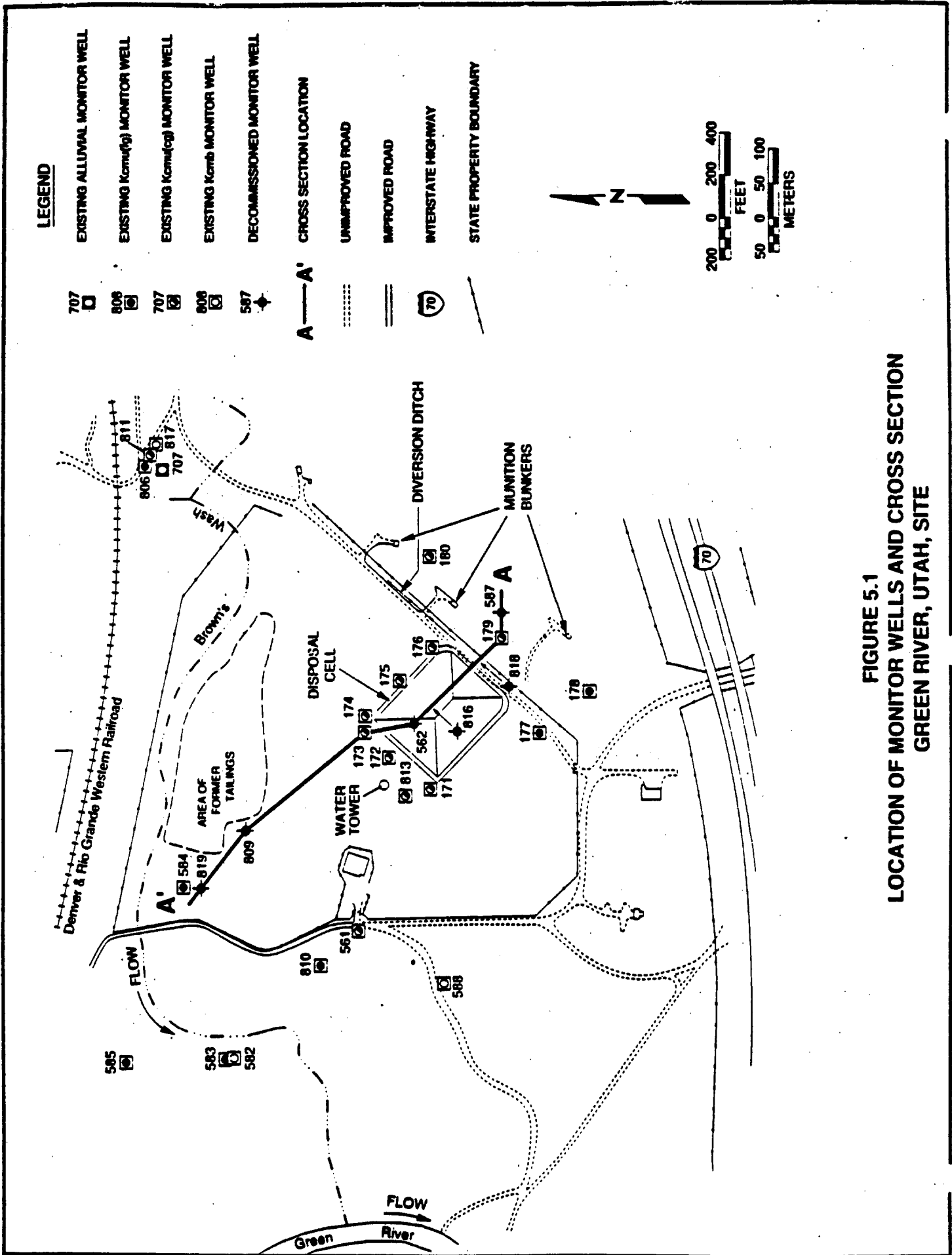
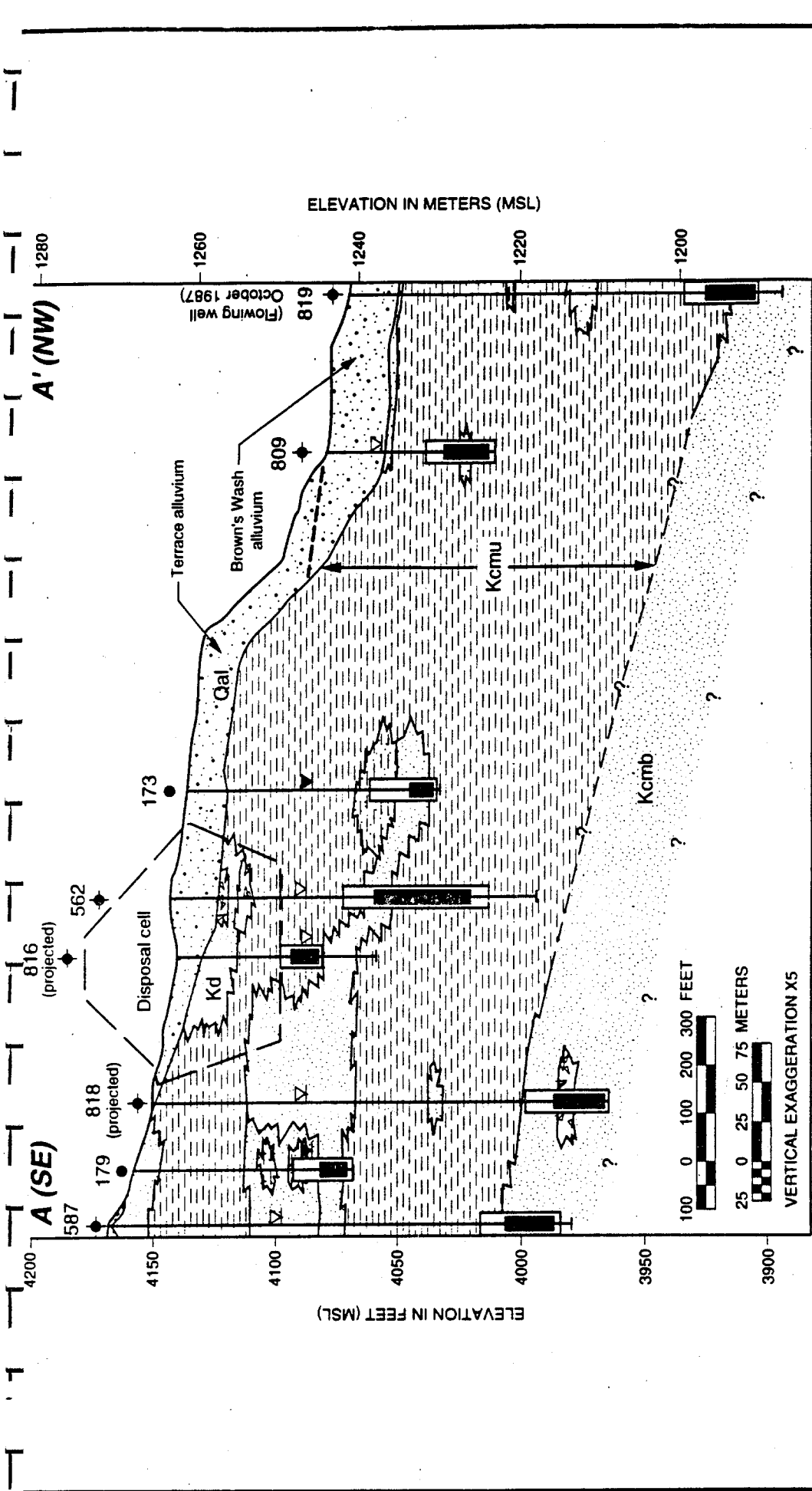

FIGURE 5.1
LOCATION OF MONITOR WELLS AND CROSS SECTION
GREEN RIVER, UTAH, SITE



LEGEND

	Brown's Wash and terrace alluvium		Qal	Alluvium	Quaternary
	Conglomerate		Kd	Dakota Sandstone	
	Sandstone		Kcmu	Cedar Mountain Formation, unnamed member	Cretaceous
	Siltstone		Kcmb	Cedar Mountain Formation, Buckhorn Member	
	Shale/claystone/mudstone with occasional limestone interbeds				

	Monitor well	● 173	Disposal site monitor well
	Ground water elevation	◆ 562	Decommissioned monitor well
	Filter pack	▽	October 1987 ground water elevation
	Well screen	▼	June 1994 ground water elevation
	Total depth		

NOTE: SEE FIGURE 5.1 FOR CROSS-SECTION LOCATION.

FIGURE 5.2
HYDROGEOLOGIC CROSS SECTION A-A' - GREEN RIVER, UTAH, SITE

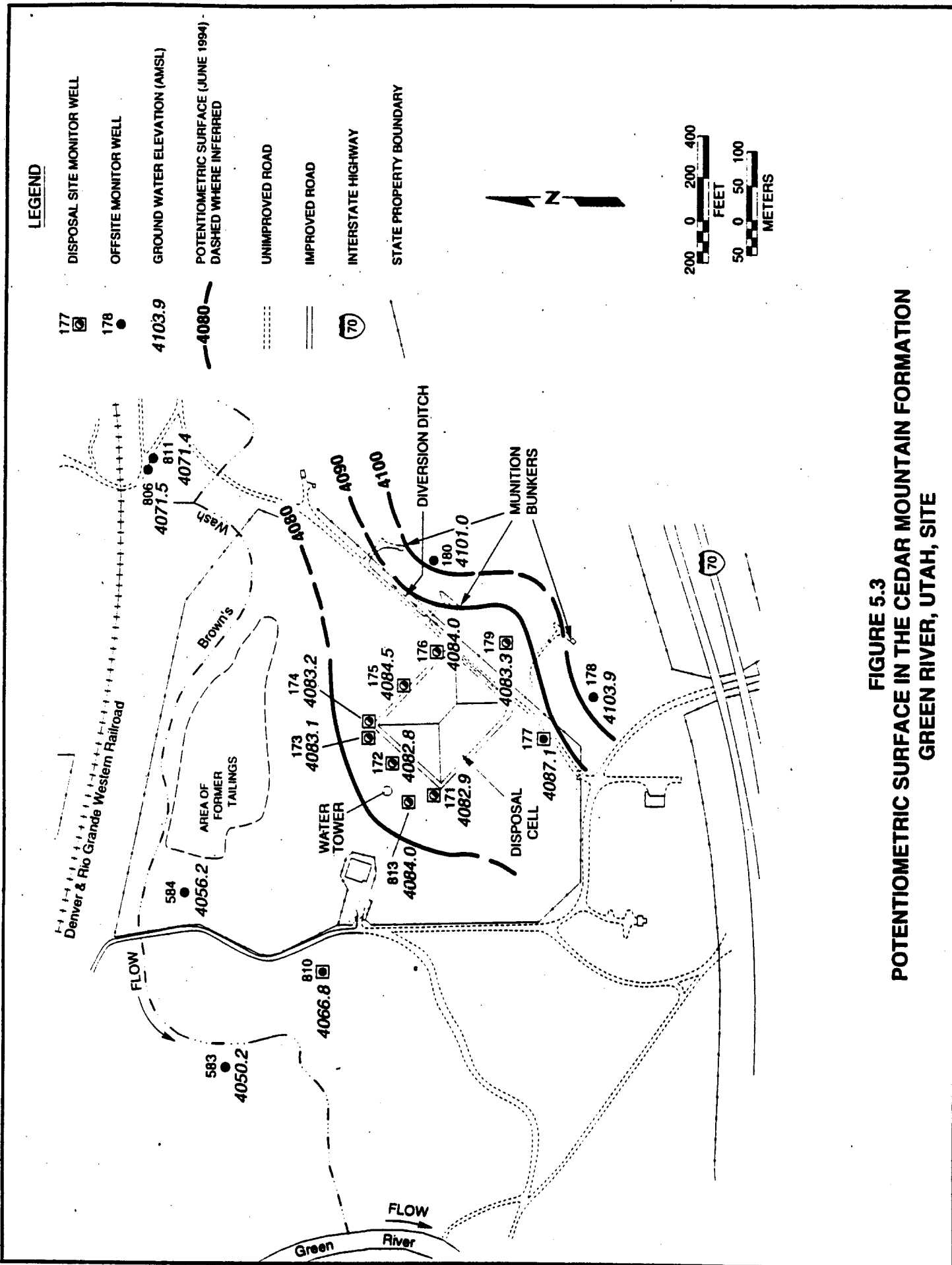

FIGURE 5.3
POTENTIOMETRIC SURFACE IN THE CEDAR MOUNTAIN FORMATION
GREEN RIVER, UTAH, SITE

5.1.2 Ground water quality

Ground water conditions in the vicinity of the Green River site are summarized below, with emphasis on the Cedar Mountain Formation (uppermost aquifer). Additional information on assessment of ground water quality at the disposal site is provided in Appendix E of Modification No. 2 to the RAP (DOE, 1998). Updated ground water quality data by location are included in Table SI.4 in the Supplemental Information attached to Appendix E of Modification No. 2 of the RAP (DOE, 1998).

Background ground water quality is defined as the quality of water if uranium milling activities had not taken place. The background ground water quality in the unnamed member and in the Buckhorn Member of the Cedar Mountain Formation is characterized by total dissolved solids (TDS) and concentrations of chloride and sulfate that exceed national primary and secondary drinking water regulations (40 CFR Parts 141 and 143). Concentrations of molybdenum, nitrate, and selenium exceed the EPA maximum concentration limits (MCL) in 40 CFR Part 192. Elevated concentrations of these constituents in ground water vary, and may represent the influence of natural sources, or other man-made sources not related to uranium processing activities.

5.1.3 Extent of contamination

Water quality data collected from monitor wells from 1986 to 1988, prior to surface remediation, indicate that uranium processing-related contamination occurs in ground water in the uppermost aquifer in the vicinity of the present disposal cell. Work began on the disposal cell in September 1988 and continued through December 1989.

Nitrate and uranium are likely to be naturally present in ground water in small concentrations. However, the association of these two constituents at the levels observed, for example in monitor well 562 (173 mg/L nitrate and 0.079 mg/L uranium), could not be due to natural processes and indicates contamination from uranium processing-related activities. Contamination related to uranium processing is present in the unnamed member of the Cedar Mountain Formation in the disposal cell area and beneath the alluvium in Brown's Wash in the former tailings pile area. Monitor wells completed in the Buckhorn Member of the Cedar Mountain Formation do not appear to be impacted by uranium processing-related activities.

Elevated concentrations of nitrate in ground water in several of the wells downgradient from the disposal cell may be accounted for by transient drainage, sources unrelated to uranium processing activities, or the "harvest water leaching hypothesis." The "harvest water leaching hypothesis" can be explained as follows: 1) high concentrations of nitrate may be present in the vadose zone beneath and downgradient from the disposal cell; 2) water from precipitation running off the disposal cell cover collects in the toe drain along the northwest side of the cell; 3) this water will then infiltrate into the vadose zone, mobilizing nitrate, which then migrates down to the water table and into the ground water.

5.2 GROUND WATER MONITORING PROGRAM

Pursuant to 40 CFR §192.03, and in accordance with the NRC regulations in 10 CFR §40.27(b)(2), a ground water monitoring plan shall be implemented, to be carried out over a period of time commencing upon completion of remedial actions taken to comply with the standards in 40 CFR §192.02, and of a duration which is adequate to demonstrate that future performance of the system of disposal can reasonably be expected to be in accordance with the design requirements of 40 CFR §192.02(c). This plan and the length of the monitoring period shall be modified to incorporate any corrective actions required under 40 CFR §192.04.

5.2.1 Previous ground water monitoring

Remedial action at the Green River site was completed in 1989. A preliminary monitoring program was initiated in 1990 to demonstrate the adequacy of the disposal cell to protect ground water. This program was based on the proposed EPA ground water protection standards that were in effect at that time (52 FR 36000 [1987]). Compliance with the standards included identification of hazardous constituents present in the residual radioactive material (RRM), establishing concentration limits for these constituents, and designating a point of compliance (POC) hydraulically downgradient from the disposal cell.

The concentration limits originally proposed for the disposal site were based on concentrations measured in ground water samples from 16 monitor wells screened in the Cedar Mountain Formation and located near the disposal cell (Figure 5.1). It was thought at the time that the large differences observed between wells, with respect to constituent concentrations, represented naturally occurring variations of the ground water chemistry within the Cedar Mountain Formation. However, recent geochemical and statistical evaluation of the ground water quality data indicates the ground water in the disposal cell vicinity was impacted by uranium processing activities that took place at the site. The strongest evidence for the presence of preexisting, processing-related contamination is indicated by two former monitor wells (562 and 816) that were in the same area of the present disposal cell, and another monitor well (807) crossgradient from the disposal cell (Figure 5.1). In the baseline risk assessment (DOE, 1994a), concentrations of several constituents associated with uranium processing (including nitrate and uranium) were determined to be elevated above background levels prior to disposal cell construction. Pre-construction water quality data from the site are provided as a supplement to Appendix E of Modification No. 2 to the RAP (DOE, 1998) (Tables SI.3 and SI.4).

The presence of preexisting contamination in the disposal cell vicinity complicates the assessment of disposal cell performance because the hazardous constituents identified in the RRM are also present in the ground water downgradient from the disposal cell. In addition, changes in concentration levels unrelated to disposal cell performance may occur at the disposal site as a result of migration of the preexisting contamination.

5.2.2 Post-closure ground water monitoring

The DOE plans to continue post-closure monitoring of ground water in the uppermost aquifer downgradient from the disposal cell. Four POC wells (171, 172, 173, and 813) have been designated, which most clearly represent the intersection of a vertical plane with the uppermost aquifer underlying the site, located at the hydraulically downgradient limit of the disposal area (40 CFR § 192.02(c)(4)) (Figure 5.1 and Table SI.1 in Appendix E of Modification No. 2 to the RAP [DOE, 1998]). Ground water samples will be collected from the POC wells on a quarterly basis for a minimum of three years (until 2001), and analyzed for the hazardous constituents listed in Table 5.1. Ground water levels will be measured on a continual basis with data loggers and pressure transducers in POC wells 171 and 173 during the three-year monitoring period. In addition, water levels will be measured in another well completely removed and uninfluenced by the disposal cell watershed by the same method. This information will be compared to local daily precipitation data collected from the meteorological station in the town of Green River. To ensure that the relationship between precipitation and ground water elevations is properly evaluated, appropriate meteorological equipment will be installed at the Green River site.

Table 5.1 Proposed concentration limits for POC wells, Green River, Utah, site

Monitor Well	Nitrate (mg/L)	Uranium (mg/L)	Sulfate (mg/L)
171	MCL	MCL	3334
172	102	0.067	4985
173	MCL	MCL	4000
813	MCL	0.069	4440

After the three year period, the need for further monitoring will be evaluated jointly between the DOE, the NRC, and the state of Utah. The DOE expects that contaminant levels will decrease to levels that existed prior to the construction of the disposal cell. If at the end of three years, the contaminant levels are not at, or trending to, pre-construction levels, a physical investigation will be conducted to determine if one or more of the potential failure scenarios listed in Section 5.3 have occurred. The cause of the increased concentrations of nitrate in ground water in the POC monitor wells, which may be accounted for by the "harvest water leaching hypothesis" (discussed in Section 5.1.3), will be tested by the ground water monitoring investigation.

For quality assurance/quality control purposes, the state of Utah Division of Radiation Control (DRC) will have the option to collect split ground water samples periodically during the three-year quarterly monitoring investigation. After the DRC has received the DOE letter notification of the scheduled sampling event, the DRC will provide the DOE with advanced notice whether or not they will collect split samples for that event.

5.3 CORRECTIVE ACTION PLAN

Pursuant to 40 CFR §192.04, the DOE will define alternative corrective actions that could be implemented to bring the site into compliance if an inspection of the cell indicates the disposal cell is not functioning properly. Also, if concentrations of hazardous constituents in ground water in the uppermost aquifer statistically exceed the established concentration limits after additional confirmation sampling, a physical investigation of the disposal cell would be undertaken to determine if one or more of the potential failure scenarios described in Table 5.2 have occurred. Although it is not possible to propose specific detailed corrective action plans, potential failure scenarios for the Green River disposal site and corrective actions are summarized in Table 5.2.

Table 5.2 Corrective action plan summary for the Green River, Utah, site

Potential failure scenario	Corrective action
Contaminated seepage emerges in artificially induced springs below the pile.	Modify cover to eliminate excess infiltration.
Radon barrier cracks due to desiccation.	Replace filter layer with lower permeability layer.
Siltation of erosion protection layer.	No action needed unless it increases infiltration or induces vegetation.
Vegetation threatens integrity of cover.	Add biointrusion layer.
Biointrusion by animals.	Modify rock cover.
Erosion of cover.	Not a realistic failure scenario (pile is designed for PMP and PMF events).
Concentration limits of indicator parameters in ground water exceeded.	Additional ground water sampling and characterization to evaluate potential of disposal cell impact on uppermost aquifer. If the "harvest water leaching hypothesis" (discussed in Section 5.1.3 above) is accepted for elevated concentrations of nitrate in ground water following evaluation of the three-year quarterly monitoring investigation, an engineering remedy may be implemented by the DOE under Subpart B of 40 CFR Part 192.

PMP - probable maximum precipitation
PMF - probable maximum flood

The Green River disposal cell was constructed of natural materials and the radon/infiltration barrier is adequately protected from disruption by animals, plants, wind, and water. The disposal cell incorporates standard safety factors on all design components and is expected to perform for a period greater than the mandated design life of 1000 years with minimal maintenance.

EPA standards require that a corrective action program to restore the disposal cell to design requirements must be implemented within 18 months if initial cell performance is not in compliance with the EPA ground water protection standards (40 CFR §192.04). The NRC regulations in Appendix A of 10 CFR Part 40 specify that the DOE will notify the NRC before implementing any significant action that may be required. The DOE will prepare and submit a corrective action plan to the NRC for review and approval. A copy of this plan also will be transmitted to the state of Utah. The corrective action plan may include indirect monitoring to demonstrate the effectiveness of the corrective action. The DOE will implement corrective action when NRC approval has been granted.

In preparing a corrective action plan, an update of the risk assessment may be performed to evaluate the potential impact to nearby populations or the environment. If the risk assessment demonstrates no potential harm to human health and the environment, the recommended corrective action may consist of "no action" except continued inspection of the disposal cell.

5.4 DATA VALIDATION AND QUALITY ASSURANCE

The UMTRA Project has established SOPs for monitor well installation and development, water and soil sampling, sample preservation and transport, field procedures, chain of custody samples for laboratory analysis, acquisition protocols, and validating and managing analytical data. All aspects of ground water monitoring are conducted in accordance with these procedures, which are updated regularly to reflect changes in industry standards, best management practices, and DOE and EPA guidance. The quality assurance procedures are consistent with the Resource Conservation and Recovery Act (RCRA) ground water monitoring technical enforcement guidance document (EPA, 1986) and the long-term surveillance and maintenance program QA plan (DOE, 1996b).

5.5 REPORTING

The DOE maintains and updates specific records and reports required to document long-term surveillance program activities at the Green River UMTRA Project site. The DOE will submit an annual report to the NRC documenting the results of the LTSP, as required by 10 CFR 27, Appendix A, Criterion 12. The DOE will keep all relevant and required records at an appropriate location. These documents will be available for review by the NRC and the public.

6.0 SITE INSPECTIONS

The three types of site inspections are as follows:

- Annual or scheduled site inspections.
- Follow-up inspections.
- Contingency inspections.

Each site inspection must be documented by a report on the findings of the inspection. Copies of the report must be forwarded to the NRC, the state of Utah, and the Green River permanent site file. Annual or scheduled site inspection reports are to be completed and filed within 90 days after the last annual (or scheduled) site inspection in that calendar year. Follow-up and contingency inspection reports are to be completed and filed within 60 days after the inspection.

6.1 INSPECTION FREQUENCY

The Green River disposal site will be inspected annually for the first 5 years following licensing. At the end of the 5-year period, the GJO will evaluate the need to continue conducting annual inspections. The recommendation will be based on an evaluation of the annual reports and any other reports that have been filed due to the need for maintenance or unscheduled events. If it is determined that inspections are required less frequently, the GJO will modify the LTSP and submit it to the NRC for acceptance. The state of Utah will also receive copies for review. Subsequent inspections would be considered scheduled site inspections.

6.2 INSPECTION TEAM

The inspection team will consist of a chief inspector and one or more assistants. The chief inspector will be a geotechnical engineer, a civil engineer, or an engineering geologist knowledgeable in the processes that could adversely affect the site (e.g., identifying geomorphic agents of change). Where necessary, the team will include additional technical experts appropriate to the problems under investigation.

6.3 PREPARATION FOR INSPECTION

Before conducting an inspection, inspectors will complete the following tasks:

- Review the final LTSP, the Green River permanent site file, previous site inspection report(s) and site inspection map(s), and any maintenance or corrective action reports.
- Prepare a site inspection checklist based on previous inspections or repairs; incorporate any modifications that may be needed.

- Verify and update the names and telephone numbers of all parties with whom access or notification agreements have been executed.
- Verify the DOE 24-hour telephone number and appropriate agency telephone numbers and contacts. Arrange to change the entrance sign as needed.
- Schedule the site inspection.
- Notify the state of Utah and the NRC that an inspection will be conducted. Determine whether any local or state concerns need to be addressed during the site inspection.
- Assemble the equipment needed to conduct the inspection.

6.4 SITE INSPECTION AND INSPECTION CHECKLIST

The site inspection will cover the disposal site area, the disposal cell, and the immediate off-site areas. All site inspection activities and observations are to be recorded and described using the as-built drawings, initial site inspection checklist (Attachment 5), site inspection map, a field notebook, and photographs. Observations and photographic stations should be recorded on the field maps. After the inspection is complete, these maps are to be drafted and retained in the Green River permanent site file.

The initial site inspection checklist (Attachment 5) is a guideline for the inspectors during their inspection. At the completion of each inspection, the checklist will be revised to include new information or to delete items that are no longer pertinent. Revisions to the checklist will be documented in the inspection report.

A photographic record of the site inspection must be maintained. Site conditions are to be documented by ground photographs to provide a record of developing trends and to enable the DOE to evaluate the need for and extent of future activities. Any site feature or condition that requires the inspectors to make a written comment, explanation, or description will be photographed, if possible. A site inspection photo log will be used to record the photographs (Attachment 4). All features will be photographed and recorded as specified in Section 3.4. The number of photographs, the view angles, and the lenses used are up to the judgment of the inspectors, as long as sufficient photographs are taken for agency review.

Off-site areas

The area within 0.25 mi (0.40 km) of the disposal site perimeter will be surveyed for the following:

- Evidence of land use changes indicating increased human activity that could increase the probability of intrusion onto the site.
- New roads or paths, changes in vegetation patterns, or relevant geomorphic features (e.g., stream channels or gullies) that could initiate site-threatening erosion.

On-site areas

The most effective way to inspect the Green River disposal site area and disposal cell is with a series of well-planned traverses around the entire perimeter of the disposal site and along the base of the disposal cell, diversion channels, sideslopes, and crest of the disposal cell. The number of traverses along the sideslopes will be determined by the height of the disposal cell. As a rule of thumb, the sideslope traverses should be spaced at 50-yd (46-m) intervals. The traverses across the crest of the disposal cell should be diagonal to the long axis of the crest. At a minimum, the disposal site perimeter and site area traverses should be selected to observe damage or disturbance to the following features:

- Site perimeter roads.
- Fences, gates, and locks.
- Permanent site surveillance features.
- Ground water monitor wells and other monitoring points.
- Other instrumentation or surveillance features.

Traverses along the engineered components (diversion ditches, cell sideslopes, cell crest, and cover) should be walked along their complete length and examined for evidence of the following:

- Structural instability due to differential settlement, subsidence, cracking, sliding, or creep.
- Erosion as evidenced by the development of rills or gullies.
- Sedimentation or debris.
- Rapid deterioration of rock caused by weathering or erosion.
- Removal of rock or other disposal cell material.
- Seepage.
- Intrusion (inadvertent or deliberate) by humans or burrowing animals.
- Vandalism.

- Development of trails from human or animal activity.
- Volunteer plant growth, especially on the disposal cell or in the diversion channels.

6.4.1 Modifying processes

Modifications of the disposal cell due to natural processes will be noted and recorded by the inspection team. Changes in the disposal cell will likely occur on the lower sections of the sideslope and around the toe apron.

Specific problems that can occur on the Green River disposal cell are as follows:

The formation of gullies near the disposal cell.

- The loss of soil due to sheet erosion around the toe apron or undercutting of the disposal cell apron.
- Plant growth on the disposal cell sideslopes.
- Migration of the main channel of the off-site diversion ditch (located immediately south of the disposal cell).
- Removal of erosion protection rock or other cover material.
- Void spaces in rock layers filling with fine-grained material carried by wind or water.

6.4.2 Vegetation

The area around the tailings embankment is graded to the north so that runoff will flow toward Brown's Wash. Graded areas were reseeded with drought-tolerant plants. Observations in 1991 indicated that the revegetation effort was a failure in that very little growth of seeded species was observed. There was, however, a dense growth of Russian thistle with an estimated vegetative cover of 24 percent (DOE, 1992b). It is expected that native species will slowly reinvade this disturbed ground over a period of a few years and that Russian thistle will remain the dominant species for years.

Only one plant was observed growing on the disposal cell in 1991; it is assumed that the rate of plant invasion of the cell will be very slow given the nature of the rock cover (DOE 1992c). Plant growth on the disposal cell, if any, will be described in the annual inspection reports.

6.5 SITE INSPECTION MAP

A new site inspection map will be prepared following each scheduled inspection using the disposal site map (Plate 2) as a base. The site inspection map will include the following:

- Inspection traverses.
- Photograph locations.
- Locations and descriptions of new, anomalous, or unexpected features.
- Features identified during previous inspections for observation or monitoring.
- Date of inspection.

6.6 REPORTING REQUIREMENTS

Upon completion of the field inspection, Section D of the initial site inspection checklist (Attachment 5) must be completed and the certification statement signed. Overlays for the as-built drawings or revised drawings should be developed, noting any potential problems or other site conditions that may require future attention. The revised drawings should be labeled with the type of site inspection and the date the site inspection was performed.

All photographs must be logged on a site inspection photo log (Attachment 4). A separate photo log should be completed for each roll of film exposed, with an entry made for each photograph. The completed photo logs are to be attached to the inspection checklist.

A site inspection report with the following information will be completed after every routine site inspection:

- Narrative of site inspection, results, conclusions, and recommendations.
- Site inspection checklist and any relevant supporting documentation.
- Site inspection map and other drawings, maps, or figures, as required.
- Inspection photographs and photo log sheet (Attachment 4).
- Recommendations for additional follow-up inspections, repair, or custodial maintenance, if required.
- Follow-up or contingency inspection reports, if required.
- Custodial maintenance or repair report and certification, if required.
- Inspection certification.
- Ground water monitoring data and analyses, if applicable.

Appendix A, Criterion 12 of 10 CFR Part 40 requires that the DOE submit the results of all routine site inspections to the NRC within 90 days of the last UMTRA Project site inspection for that calendar year. A copy of all site inspection reports will be maintained in the Green River permanent site file. A copy of the inspection report will also be sent to the state of Utah.

7.0 UNSCHEDULED INSPECTIONS

Unscheduled inspections arise from reports or information indicating that site integrity has been or may be compromised. The need for an unscheduled inspection may be triggered by any of the following:

- Findings from an annual or scheduled site inspection.
- Other site visits, such as for ground water sampling, special studies, corrective action, or other DOE activities.
- Reports from law enforcement agencies or the public.
- Reports from the Earthquake Early Warning Service or the National Weather Service (NWS).

7.1 FOLLOW-UP INSPECTIONS

Follow-up inspections are unscheduled inspections conducted to investigate and quantify specific site problems detected during a scheduled inspection, ground water sampling event, special study, or other DOE activity. They assess whether processes currently active on or near the site pose any future threat to the site if left unchecked and evaluate the need for custodial maintenance, repair, or corrective action.

Follow-up inspections should be made by technical specialists in the discipline appropriate to the problem that has been identified. For example, if erosion is the problem, the inspector(s) should be knowledgeable in evaluating erosion processes (such as a soils scientist or geomorphologist). If settlement or sliding is the problem, a geotechnical engineer would be the appropriate inspector.

The first step of the follow-up procedure is an on-site visit to determine the need for definitive tests or studies. Additional visits may be scheduled if more data are needed to draw conclusions and recommend corrective action.

After the follow-up inspection, the DOE will analyze the information gathered; assess the situation; prepare an inspection report describing the site conditions; and, if necessary, outline recommendations for further action. If maintenance, repair, or corrective action is warranted, the DOE will notify the NRC, the state of Utah, and adjacent residents as specified in Section 9.0.

7.2 CONTINGENCY INSPECTIONS

Contingency inspections are unscheduled inspections ordered by the DOE when it receives information indicating that site integrity has been or may be threatened. Examples of events that could trigger contingency inspections include reports of severe vandalism, intrusion by humans or livestock, severe rainstorms or floods, or unusual events such as tornadoes or earthquakes.

An assessment of each unusual event must be submitted to the NRC within 60 days of an initial report that damage or disruption has occurred at the disposal site (10 CFR Part 40). The state of Utah will receive a copy of this report. At a minimum, this report must include the following:

- A description of the problem.
- A preliminary assessment of the maintenance, repair, or corrective action required.
- Conclusions and recommendations.
- Assessment data, including field and inspection data, and photographs.
- Field inspector names and qualifications.

A copy of the report and all other data and documentation will be maintained in the Green River permanent site file. The annual report to the NRC will also include the results of these contingency inspection reports. If appropriate, the annual (or scheduled) Green River site inspection report will also contain the results of these inspections.

8.0 CUSTODIAL MAINTENANCE OR REPAIR

Custodial maintenance will be performed as needed at the Green River disposal site. In general, the decision to conduct maintenance or repair will be based on the results of annual, follow-up, or contingency inspections.

8.1 PLANNED MAINTENANCE

No routine maintenance is planned for the Green River disposal site.

8.2 UNSCHEDULED MAINTENANCE OR REPAIR

Unscheduled custodial maintenance activities that may be required at the Green River disposal site include the following:

- Repair the gate.
- Replace the entrance sign or perimeter warning signs.
- Reestablish survey control and boundary monuments.
- Make repairs due to animal burrows on the disposal cell.
- Remove volunteer plant growth on the disposal cell or in the diversion channels.

For these types of custodial actions, the GJO will prepare a purchase order that contains a statement of work (SOW) authorizing the repair. This SOW will include contractor qualifications.

If problems are identified that may affect the integrity of the disposal cell or compliance with 40 CFR 192, the NRC must approve any recommended, unscheduled action in advance. The action will be treated as a corrective action (Section 9.0).

8.3 CERTIFICATION AND REPORTING REQUIREMENTS

The following information on unscheduled maintenance or repair must be provided in the site inspection report and included in the annual report to the NRC:

- Summary of work required.
- Work order, purchase order, or SOW.
- Contractor qualifications, if applicable.
- Contractor documentation of completion of work.
- DOE certification of completion of work.

After the work is completed, the contractor must submit verification of the completed work in a written report if the action is considered significant. The DOE will inspect the site, as necessary, and review the report before certifying that all work is complete in accordance with all required specifications. Copies

of all records, documentation, and certifications will be included in the Green River permanent site file. Copies of all relevant documentation will be included in the annual report to the NRC and will also be transmitted to the state of Utah.

9.0 CORRECTIVE ACTION

If natural or unforeseen events threaten the stability of the disposal cell, a corrective action could include temporary emergency measures. In addition, the DOE would evaluate the factors that caused the problem to ensure that recurrence is minimized or avoided.

When a potential problem has been identified, the DOE will notify the NRC and the state of Utah and submit an inspection/preliminary assessment report to the NRC for review within 60 days. The preliminary assessment report will evaluate the problem and recommend the next step (e.g., immediate action or continued evaluation). After the NRC has reviewed the report and recommendations, the DOE will develop a corrective action plan for NRC approval. The DOE may combine the inspection and recommendation in one report, depending on the severity of the problem. Once the NRC approves the corrective action, the DOE will implement the plan. Figure 9.1 illustrates the general sequence of events in the corrective action process. Figure 9.2 identifies the key elements in the corrective action process.

NRC regulations do not stipulate a time frame for implementing corrective action. However, the EPA ground water regulations (40 CFR §192.04) require that a corrective action program be placed into operation no later than 18 months after an exceedance is confirmed at a disposal cell. Assessing the extent of the problem and developing a corrective action plan will not be considered initiation of the corrective action program. Section 9.0 of the UMTRA Project LTSP guidance document (DOE, 1992a) contains details on corrective action.

9.1 PROBLEM IDENTIFICATION

Site inspections by qualified inspectors and custodial maintenance are designed to identify problems at the developmental stage, eliminating the need for corrective action. However, extreme natural events, vandalism, or unanticipated events may create the need for additional data or evaluative monitoring to assess whether uncorrected problems would threaten disposal site integrity. An on-site inspection/preliminary assessment would include, but would not be limited to, the following:

- Quantifying the nature and extent of the problem.
- Reevaluating the engineering design parameters germane to the problem.
- Establishing a data collection and/or evaluative monitoring program to
- Quantify the magnitude of the problem.

9.2 CERTIFICATION AND REPORTING REQUIREMENTS

The DOE will prepare progress reports on each corrective action while it is under way or under evaluation. The NRC will be given a copy of each report, or the

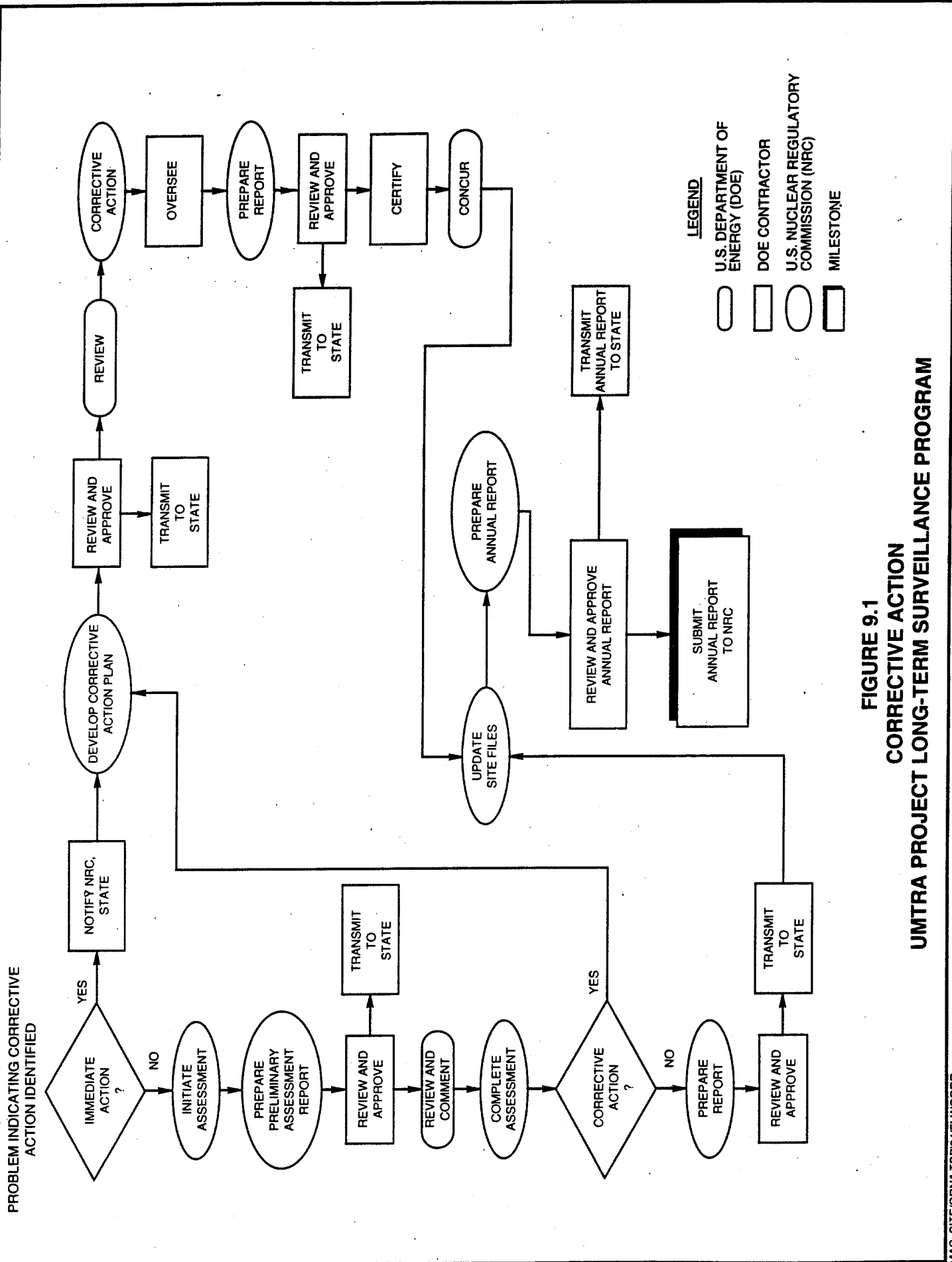

LEGEND

- U.S. DEPARTMENT OF ENERGY (DOE)
- DOE CONTRACTOR
- U.S. NUCLEAR REGULATORY COMMISSION (NRC)
- MILESTONE

FIGURE 9.1
CORRECTIVE ACTION
UMTRA PROJECT LONG-TERM SURVEILLANCE PROGRAM

NEED FOR CORRECTIVE ACTION IDENTIFIED

- DOCUMENT AND REPORT PROBLEM TO NRC, STATE, AND TRIBES
- EVALUATE PROBLEM AND PROPOSE A SOLUTION
- DEVELOP CORRECTIVE ACTION PLAN AND NOTIFY NRC, STATE
- SELECT CONTRACTOR TO PERFORM CORRECTIVE ACTION
- ESTABLISH CONTRACTUAL CONDITIONS FOR PERFORMING CORRECTIVE ACTION AND GUARANTEE CORRECTIVE ACTION WILL BE PERFORMED IN ACCORDANCE WITH CONTRACTUAL AGREEMENTS AND DESIGN SPECIFICATIONS

IMPLEMENTATION

- MONITOR PROGRESS OF CORRECTIVE ACTION
- VERIFY COMPLETION OF CORRECTIVE ACTION

CERTIFICATION

- VERIFY CORRECTIVE ACTION AS DESIGNED CORRECTS THE PROBLEM
- ENSURE RECURRENCE OF PROBLEM IS MINIMIZED OR AVOIDED
- CERTIFY COMPLETION OF CORRECTIVE ACTION IN ACCORDANCE WITH 40 CFR PART 192 (1994)
- SUBMIT CERTIFICATION REPORT TO NRC

FROM DOE, 1992a

FIGURE 9.2
KEY ELEMENTS IN THE CORRECTIVE ACTION PROCESS

report will be attached to the annual report. The NRC will be informed of all potential problems and solutions. All reports will be provided to the state of Utah.

After corrective action is complete, all work completed will be certified in accordance with EPA standards. The NRC will review this certification. A copy of the DOE certification statement will become part of the Green River permanent site file, as will all reports, data, and documentation generated during the corrective action.

10.0 RECORD KEEPING AND REPORTING REQUIREMENTS

The DOE will maintain the Green River permanent site file containing all information needed to prepare for and conduct site surveillance. Carefully compiled, complete, accurate reports of site surveillance activities will be maintained in accordance with archival procedures established in 41 CFR Part 101 and 36 CFR Parts 1220-1238 (Subchapter B - Records Management).

As required by 10 CFR 40.27, the DOE will provide an annual report to the NRC documenting the results of the long-term surveillance program. Copies of the annual report will be provided to the state of Utah and will be added to the Green River permanent site file. The annual reports and supporting documentation in the permanent site files will accomplish the following:

- Document the history of disposal site performance.
- Demonstrate to the NRC that license provisions were met.
- Provide the DOE and the NRC with the information necessary to forecast future disposal site surveillance and monitoring needs.
- Provide information to the public to demonstrate that site integrity has been maintained.

10.1 RECORDS

The GJO will maintain the Green River permanent site file in Grand Junction, Colorado. All original deeds, custody agreements, and other property documents will be maintained in the DOE Facilities and Property Management Division, Albuquerque, New Mexico. Copies of these documents also will be maintained in GJO files.

Surveillance and maintenance documentation maintained at the GJO will exist as a record collection separate from the UPDCC. As such, the records will be handled in accordance with DOE Order 1324.2A, *Records Disposition*, to ensure proper handling, scheduling, and disposition of documents.

- All information will be available for NRC and public review. The Green River permanent site file will include the following:
 - Licensing documentation.
 - The site-specific LTSP.
 - Disposal site legal description, title, custody documentation and cooperative agreements.

- Interagency agreements, authorizations, and access agreements.
- Notification requests with the USGS, the Emery County Sheriff's Office, and the Grand County Sheriff's Department.
- Documentation of rights of entry.
- The Green River EA and finding of no significant impact.
- The disposal site characterization report and/or processing site characterization report.
- The final RAP and final design for construction.
- Pertinent design and construction documents and drawings.
- The site certification report (certification summary, completion report, and final audit report).
- As-built drawings.
- The site atlas (vicinity, topographic, and base maps).
- Baseline and aerial photographs.
- Ground water monitoring reports and records.
- Additional monitoring reports and records.
- Monitor well permits and well abandonment records.
- Annual reports to the NRC.
- Annual inspection reports and records.
- Follow-up or contingency inspection preliminary assessments, reports, and records.
- Custodial maintenance or repair reports and records.
- Corrective action plans, reports, and records.
- The QA program plan.

An index of the Green River permanent site file is provided in Attachment 3. The GJO will update the Green River permanent site file, as necessary, after the annual disposal site inspections are complete. Original UMTRA Project

records and files will be archived with the DOE GJO Grand Junction, Colorado.

10.2 REPORTS

The GJO will provide an annual report to the NRC, documenting the results of the annual site inspections and any other activities conducted in conjunction with the long-term surveillance program. Criterion 12 to Appendix A of 10 CFR Part 40 requires that the report be submitted within 90 days after the date of the last UMTRA Project site inspection for that calendar year.

The GJO also will submit reports to the NRC documenting follow-up or contingency inspections and any corrective action plans. If any unusual damage or disruption is discovered, Criterion 12 to Appendix A of 10 CFR Part 40 requires that all preliminary inspection reports be submitted within 60 days of the discovery.

The results of the ground water monitoring program will be reported annually to the NRC.

11.0 EMERGENCY NOTIFICATION AND REPORTING

The Green River disposal cell was designed to comply with 40 CFR Part 192 with minimum maintenance and oversight for a period of 1000 years, or at least 200 years. However, unforeseen events could create problems that may affect the disposal cell's ability to remain in compliance with 40 CFR Part 192. Therefore, the DOE has requested notification from state and federal agencies of discoveries or reports of any purposeful intrusion or damage at the disposal site as well as the occurrence of earthquakes, tornadoes, or floods in the disposal site area.

11.1 AGENCY AGREEMENTS

The DOE has negotiated formal agreements with the Grand County Sheriff's Department and the Emery County Sheriff's Office to notify the DOE when purposeful intrusion or damage is discovered. The DOE has also arranged for the USGS National Earthquake Information Center to notify the DOE in the event of an earthquake, in the disposal site area (Attachment 6). These agreements will be updated as needed.

In accordance with the agreements, the UMTRA Project Office will be the designated facility contact until the Green River disposal site is brought under the general license. After that, the designated facility contact will be the GJO.

Response letters from all of the agencies will be kept in the Green River permanent site file. Contact lists and telephone numbers for all agencies with whom the DOE has entered into agreements will be updated annually, in conjunction with the site inspection, for inclusion in the disposal site inspection report.

To further solidify written agreements with these agencies, the DOE GJO will periodically contact these agencies to update them about the location of and concerns for the Green River disposal site.

11.2 UNUSUAL OCCURRENCES

The DOE has requested that the GJO be notified of any unusual occurrences in the disposal site area that may affect surface or subsurface stability. The Grand County Sheriff's Department and the Emery County Sheriff's Office have agreed to notify the GJO if anything out of the ordinary (e.g., human intrusion, fire) is observed by the staff or reported to the office (Attachment 6).

11.3 EARTHQUAKES

The DOE subscribes to the USGS Early Warning Service for notification when an earthquake is of sufficient magnitude to threaten a disposal site. This service provides data on the magnitude of the event and the location of the epicenter.

The USGS National Earthquake Information Center will notify the GJO if a seismic event(s) occurs that fits any of the following descriptions:

- Any earthquake of magnitude 3.0 or greater, within 0.3 degree (about 20 mi [30 km]) of the site.
- Any earthquake of magnitude 5.0 or greater, within 1.0 degree (about 70 mi [110 km]) of the site.

12.0 QUALITY ASSURANCE

The GJO is responsible for developing QA procedures specific to the UMTRA Project long-term surveillance program. The GJO QA Program Plan (DOE, 1996b) specifies the following requirements:

- Program planning.
- Program activities, including inspections, site maintenance, corrective action, and emergency response.
- Monitoring, if required.
- Personnel qualifications and training.
- Program surveillance and audits.
- Analytical QA.
- Analytical data validation.

All site inspections, monitoring data, records, photographs, maps, and other information related to the long-term surveillance program for the Green River disposal site are subject to formal and unannounced audits by the DOE UMTRA Project Office or the NRC. Specific QA criteria have already been developed for aerial photographs (DOE, 1996b).

13.0 PERSONNEL HEALTH AND SAFETY

DOE Order 5480.1B, *Environmental Safety and Health Program for DOE Operations*, establishes personnel health and safety procedures for all DOE operations. After a disposal site is licensed and transferred to the GJO, it will be responsible for health and safety procedures for GJO personnel and subcontractors. The GJO will determine health and safety requirements for its personnel in accordance with applicable orders and federal regulations. Because the disposal cell was constructed to control radium-226 and radon-222 releases from the RRM to within regulatory standards 40 CFR §192.02(a), radiation exposure tracking and dosimetry badges will not be needed.

13.1 HEALTH AND SAFETY

13.1.1 Unusual hazards and specific safety concerns

The mill site was used to process ores and assemble rocket components. Some of the potential hazards arising from these activities include solvents, degreasers, acids, and bases. Located at the old mill site are abandoned buildings that may be structurally unsound; therefore, employees should stay clear of them as much as possible. The disposal cell does not appear to pose a significant radiological hazard; however, the disposal cell is covered with loose, jagged cobblestone, and injuries may result from slipping, falling, or tripping on the cell cover. Other possible hazards associated with the Green River disposal site include a small, intermittent stream that runs nearby; electric power lines (345 kilovolts) crossing the disposal site; possible buried utility lines; and a buried propane pipeline and tank at the mill site.

13.1.2 Emergency medical and law enforcement

Local emergency medical and law enforcement agencies have been briefed on the scope of work at the Green River disposal site during the long-term surveillance and maintenance phase. The following 24-hour emergency number is pertinent:

Fire:	(801) 564-8111
Ambulance:	(801) 564-8111 (helicopter available)
Police/sheriff:	(801) 564-8111

The nearest hospital with an emergency room is in Moab, Utah, 60 mi (100 km) south from Green River. Green River has a clinic staffed by nurses that is located at 110 S. Medical Street.

13.2 REPORTABLE INCIDENTS

The inspection team should be briefed by the GJO health and safety officer on potential site hazards and other requirements prior to site inspections or visits.

In accordance with DOE Order 5000.3B, any accident, injury, or environmental event (e.g., tornado, flood, etc.) occurring during the site inspection is a reportable

incident. The condition or event will be reported to the GJO facility manager or designated contact within 8 hours of the occurrence. The GJO facility manager's 24-hour telephone number for reporting an incident is (970) 248-6070.

14.0 REFERENCES

- Brookins, D.G., 1988. *Eh-pH Diagrams for Geochemistry*: Springer-Verlag, Heidelberg, 176 p.
- DOE (Department of Energy), 1998. *Modification No. 2 to the Remedial Action Plan and Site Design for Stabilization of the Inactive Uranium Mill Tailings Site at Green River, Utah*, March 1998, DOE/AL/62350-050510.GRNO, DOE UMTRA Project, DOE Environmental Restoration Division, Albuquerque, New Mexico.
- DOE (Department of Energy), 1996a. *Guidance for Implementing the Long-Term Surveillance Program for UMTRA Project Title I Disposal Sites*, February 1996, DOE/AL/62350-189, Rev. 0, DOE UMTRA Project, DOE Environmental Restoration Division, Albuquerque, New Mexico.
- DOE (U.S. Department of Energy), 1996b. *Long-Term Surveillance and Maintenance Program, Quality Assurance Program Plan, AC-2152, Rev. 0*, prepared by MACTEC Environmental Restoration Services, for the U.S. Department of Energy, Grand Junction Office, Grand Junction, Colorado.
- DOE (Department of Energy), 1994. *Baseline Risk Assessment of Ground Water Contamination at the Uranium Mill Tailings Site Near Green River, Utah*, September 1994, DOE/AL/62350-116, Rev. 0, DOE UMTRA Project, DOE Environmental Restoration Division, Albuquerque, New Mexico.
- DOE (U.S. Department of Energy), 1993. *Licensing Plan for UMTRA Project Disposal Sites*, final, September 1993, DOE/AL/62350-9F, prepared by the U.S. Department of Energy, UMTRA Project Office, Albuquerque Operations Office, Albuquerque, New Mexico.
- DOE (U.S. Department of Energy), 1992a. *Guidance for Implementing the UMTRA Project Long-term Surveillance Program*, UMTRA-DOE/AL-350125.0000, Rev. 1, prepared by the U.S. Department of Energy, UMTRA Project Office, Albuquerque Operations Office, Albuquerque, New Mexico.
- DOE (U.S. Department of Energy), 1992b. *Vegetation Growth Patterns on Six Rock-Covered UMTRA Project Disposal Cells*, UMTRA-DOE/AL-400677.0000, February 1992, prepared by the U.S. Department of Energy, UMTRA Project Office, Albuquerque Operations Office, Albuquerque, New Mexico.
- DOE (U.S. Department of Energy), 1992c. *1991 Annual Prelicensing Inspection of the Green River, Utah, UMTRA Project Disposal Site*, DOE/ID/12584-98, prepared by the U.S. Department of Energy, UMTRA Project Office, Albuquerque Operations Office, Albuquerque, New Mexico.
- DOE (U.S. Department of Energy), 1991. *Remedial Action Plan and Site Conceptual Design for Stabilization of the Inactive Uranium Mill Tailings Site at Green River, Utah*, UMTRA-DOE/AL-050510.GRNO, prepared by the U.S. Department of Energy, UMTRA Project Office, Albuquerque Operations Office, Albuquerque, New Mexico.

- DOE (U.S. Department of Energy), 1990. *Requirements for Quality Control of Analytical Data*, DOE/HWP-65/R1, Hazardous Waste Remedial Actions Program/Oak Ridge Operations Office, Oak Ridge, Tennessee.
- DOE (U.S. Department of Energy), 1989. *Regulatory Alternatives for Groundwater Compliance for the DOE's UMTRA Project*, "Alternate Concentration Limits, Supplemental Standards, and Institutional Controls for the Department of Energy's UMTRA Project," UMTRA-DOE/AL-400659.0000, March 1989, prepared by the U.S. Department of Energy, UMTRA Project Office, Albuquerque Operations Office, Albuquerque, New Mexico.
- DOE (U.S. Department of Energy), 1988. *Environmental Assessment of Remedial Action at the Green River Uranium Mill Tailings Site, Green River, Utah*, DOE/EA-0343, prepared by the U.S. Department of Energy, UMTRA Project Office, Albuquerque Operations Office, Albuquerque, New Mexico.
- EPA (U.S. Environmental Protection Agency), 1991. *Groundwater Protection Standards*, SAR 1166, Document GWSTDI.WP5, Office of Radiation Programs, Washington, D.C.
- EPA (U.S. Environmental Protection Agency), 1989. *Statistical Analysis of Groundwater Monitoring Data at RCRA Facilities - Interim Final Guidance*, EPA/530-SW-89-026, Washington, D.C.
- EPA (U.S. Environmental Protection Agency), 1988a. *Guidance on Remedial Actions for Contaminated Ground Water at Superfund Sites*, EPA/540/G-88-003, OSWER Directive 9283.1-2, Washington, D.C.
- EPA (U.S. Environmental Protection Agency), 1988b. *Statement of Work for Organic Analysis*, Contract Laboratory Program, Statement of Work No. 288, Washington, D.C.
- EPA (U.S. Environmental Protection Agency), 1986. *RCRA Groundwater Monitoring Technical Enforcement Guidance Document (TEGD)*, OSWER Directive 9950.1, Washington, D.C.
- JEG (Jacobs Engineering Group Inc.), 1993. *UMTRA Technical Assistance Contractor Quality Assurance Program Plan*, DOE/AL/62350-56, Rev. 4, prepared by Jacobs Engineering Group Inc., Albuquerque, New Mexico, for the U.S. Department of Energy, UMTRA Project Office, Albuquerque Operations Office, Albuquerque, New Mexico.
- JEG (Jacobs Engineering Group Inc.), n.d. *Albuquerque Operations Manual*, standard operating procedures, prepared by Jacobs Engineering Group Inc., Albuquerque, New Mexico, for the U.S. Department of Energy, UMTRA Project Office, Albuquerque Operations Office, Albuquerque, New Mexico.
- Krauskopf, K.B., 1979. *Introduction to Geochemistry*: McGraw-Hill, New York, 617 p.

- Laronne, J.B., and Shen, H.W., 1982. "Temporal and spatial variations of solute pickup during runoff generation in saline hillslopes": in Singh, V.P., ed., *International Symposium on Rainfall Runoff Modeling: Modeling Components of the Hydrologic Cycle*, Water Resource Publication, Littleton, CO.
- MK-F (MK-Ferguson), 1991. *Green River, Utah, Final Completion Report*, prepared by MK-Ferguson for the U.S. Department of Energy, UMTRA Project Office, Albuquerque Operations Office, Albuquerque, New Mexico.
- NRC (U.S. Nuclear Regulatory Commission), 1990. *Final Technical Evaluation Report for the Proposed Remedial Action at the Green River Tailings Site, Green River, Utah*, Washington, D.C.
- Shacklette, H.T., Boerngen, J.G., and Keith, J.R., 1974. *Selenium, Fluorine, and Arsenic in Surficial Materials of the Conterminous United States*: U.S. Geological Survey Circular 692, Washington, D.C., 14 p.
- Stokes, W.L., 1944. *Morrison Formation and Related Deposits in and Adjacent to the Colorado Plateau*: Bulletin of the Geological Society of America, v. 55, p 951-992.
- Young, R.G., Million, I, and Hausen, D.M., 1960. *Geology of the Green River Mining District, Emery and Grand Counties, Utah*: U.S. Atomic Energy Commission Report RME-98 (revised), 89 p.

DOE ORDERS

- Order 1324.2A, *Records Disposition*, April 9, 1992, U.S. Department of Energy, Office of Information Resources Management, Washington, D.C.
- Order 5000.3B, *Occurrence Reporting and Processing of Operations Information*, February 22, 1993, U.S. Department of Energy, Albuquerque Operations Office, Albuquerque, New Mexico.
- Order 5400.1, *General Environmental Protection Program*, June 29, 1990, U.S. Department of Energy, Environmental Protection Division, Office of Environment, Safety and Health, Washington, D.C.
- Order 5480.1B, *Environment, Safety and Health (ES&H) Program for DOE Operations*, September 1986, U.S. Department of Energy, Safety Programs Division, Washington, D.C.
- Order 5700.6C, *Quality Assurance*, August 21, 1991, U.S. Department of Energy, Office of Nuclear Energy and Office of Environment, Safety, and Health, Washington, D.C.

FEDERAL REGISTER

52 FR 36000, "Standards for Remedial Actions at Inactive Uranium Processing Sites; Proposed Rule," September 24, 1987.

55 FR 45591, "Custody and Long-Term Care of Uranium and Thorium Mill Tailings Disposal Sites," October 30, 1990.

UNITED STATES CODE

42 USC §7901 et seq., *Uranium Mill Tailings Radiation Control Act*, November 8, 1978.

U.S. CODE OF FEDERAL REGULATIONS

10 CFR Part 40, *Domestic Licensing of Source Material*, U.S. Nuclear Regulatory Commission.

36 CFR Parts 1220-1238, *National Archives and Records*, Subchapter B - Records Management, National Archives and Records Administration.

40 CFR Part 141 National Primary Drinking Water Regulations.

40 CFR Part 143. *National Secondary Drinking Water Regulations*.

40 CFR Part 192, *Health and Environmental Protection Standards for Uranium and Thorium Mill Tailings*, U.S. Environmental Protection Agency.

40 CFR Part 264, *Standards for Owners and Operators of Hazardous Waste Treatment, Storage, and Disposal Facilities*, U.S. Environmental Protection Agency.

41 CFR Part 101, *Federal Property Management Regulations*, General Services Administration.

15.0 LIST OF CONTRIBUTORS

The following individuals contributed to the preparation of this LTSP.

Name	Contribution
J. McBee	Site manager, document review
S. Cox	Site manager, document review
P. Martinez	Real estate specialist
J. Lommler	Engineering, ground water hydrology
D. Heydenburg	Ground water hydrology
L. LaVigne	Project Secretary

ATTACHMENT 1

NRC CONCURRENCE AND LICENSING DOCUMENTATION

U.S. DEPARTMENT OF ENERGY
CERTIFICATION SUMMARY
for the
Green River, Utah, Disposal Site

The Uranium Mill Tailings Remedial Action Project Manager and the Contracting Officer for the U.S. Department of Energy certify that the Green River, Utah, remedial action is complete. Surface contamination at the mill site has been placed in a disposal cell on site. The remedial action meets all the design criteria and technical specifications contained in the approved Remedial Action Plan, as required under Public Law 95-604. This certification applies to the surface remediation. The groundwater restoration activities associated with existing contamination at the mill site will be completed separately. The undersigned request that the U.S. Nuclear Regulatory Commission concur in this certification.

Melanie J. Thomas

Melanie J. Thomas
Contracting Officer
Programs and R&D Branch
Contracts and Procurement Division

DATE: April 1, 1992

Albert R. Chernoff

Albert R. Chernoff
Project Manager
Uranium Mill Tailings Remedial
Action Project Office

DATE: 3/23/92

The Chief, Uranium Recovery Branch, Division of Low-Level Waste Management and Decommissioning, U.S. Nuclear Regulatory Commission hereby concurs with the U.S. Department of Energy's completion of surface remedial action at the Green River, Utah, combined processing and disposal site.

John J. Surmeier

Mr. John J. Surmeier
Chief, Uranium Recovery Branch
Division of Low-Level Waste
Management and Decommissioning
U.S. Nuclear Regulatory Commission

DATE: July 16, 1992

U.S. Department of Energy
Agreement No. DE-FC04-81AL16257
Appendix B (Remedial Action Plan)
for Green River, Utah

SIGNATURE PAGE

THE UNITED STATES OF AMERICA
DEPARTMENT OF ENERGY

By: *Mark L. Matthews*

Mark L. Matthews
Acting Project Manager
Uranium Mill Tailings Project Office
Albuquerque Operations Office
P.O. Box 5400
Albuquerque, New Mexico 87115

Date: JAN 22 1990

STATE OF UTAH

By: *Ken Alkema*

Ken Alkema, Director
Division of Environmental
Health
Utah Department of Health

Date: JAN 22 1990

CONCURRENCE

NUCLEAR REGULATORY COMMISSION

By: *Paul H. Lohaus*

Paul H. Lohaus, Chief
Operations Branch
Division of Low Level Waste
Management & Decommissioning

Date: March 22, 1990

(See TER transmittal letter dated March 22, 1990,
for conditions of concurrence)

NRC licensing documentation
will be included when the site is licensed.

ATTACHMENT 2

SITE OWNERSHIP/CUSTODY DOCUMENTATION

REAL ESTATE DOCUMENTATION

GENERAL

The Uranium Mill Tailings Radiation Control Act of 1978 (UMTRCA), as amended, required the Secretary of Energy to permanently acquire land needed to carry out the purposes of the UMTRCA. Pursuant to the Cooperative Agreement between the state of Utah and the DOE, the state acquired the Green River site. The site was acquired by the Utah Division of Environmental Health from Umetco Minerals Corporation. Upon completion of remedial action, the state of Utah conveyed title of the site to the United States of America.

The acquisition associated with the Green River disposal site included surface and subsurface rights and all easements and rights-of-way appearing of record. The area encompassed by the final site boundary is 25.27 ac (10.2 ha).

LEGAL DESCRIPTION OF FINAL SITE BOUNDARY

A parcel of land situated in the SE1/4 SE1/4 of Section 15 and in the NE1/4 of Section 22, Township 21 South, Range 16 East of the Salt Lake Base & Meridian (SLB&M), Grand County, Utah, being described as follows:

BEGINNING AT A POINT which is S32°37'09"W 296.82 feet from the NE corner of Section 22, T21S R16E, SLB&M, (being a found 6"X6" sandstone rock) and considering the East line of the SE1/4 of Section 15, T21S, R16E, SLB&M to bear N00°00'00"E and all other bearings contained herein to be relative thereto;
thence S41°35'50"W 1166.99 feet;
thence N47°18'14"W 126.13 feet to a found 1990 31/4" aluminum cap, stamped SM-1,
thence N47°18'14"W 233.28 feet to a found 1989 31/4" aluminum cap;
thence N76°10'38"W 552.07 feet to a found 1990 31/4" aluminum cap; stamped SM-2;
thence N00°00'39"W 182.13 feet to a found 1989 31/4" aluminum cap;
thence N51°27'10"E 377.19 feet to a found 1989 31/4" aluminum cap;
thence S79°03'39"E 157.85 feet to a found 1989 31/4" aluminum cap;
thence N42°54'38"E 95.40 feet to a found 1989 31/4" aluminum cap;
thence N01°58'54"E 145.17 feet to a found 1989 31/4" aluminum cap;
thence N50°20'54"E 493.71 feet to a found 1989 31/4" aluminum cap;
thence S82°32'39"E 463.73 feet to a found 1989 31/4" aluminum cap;
thence S48°20'01"E 291.16 feet to a found 1990 31/4" aluminum cap, stamped SM-3;
thence S48°20'01"E 61.46 feet;
thence S21°02'19"W 134.50 feet to the **POINT OF BEGINNING**, containing 25.27 acres as described.

Filed: October 28, 1996 at Entry No. 438175, Book 494 on Pages 22-23, Grand County Recorder's Office, 125 E. Center Moab, Utah 84532, Grand County, Utah.

LEGAL DESCRIPTION OF STATE-OWNED PROPERTY

A parcel of land situated in parts of Sections 14, 15, and 22, Township 21 South, Range 16 East of the SLB&M, Grand County, Utah, being described as follows:

BEGINNING AT A POINT which is S32°37'09"W, 296.82 feet from the northeast corner of Section 22, T21S, R16E and running thence S41°35'50"W, 1310.46 feet; thence S90°00'00"W, 830.00 feet; thence N21°03'48"W, 1585.97 feet; thence N22°54'21"E, 770.78 feet; thence N77°45'28", 1084.67 feet; thence S82°56'32"E, 1058.02 feet; thence S9°27'44"E, 669.10 feet; thence S21°02'15"W, 696.42 feet to **POINT OF BEGINNING**.

This was established in 1988 as a "zone change request" for the project construction boundary, to Grand County, Utah (MK-F memorandum of 04 February 1988).

PERPETUAL EASEMENT

The DOE, ACE, and U.S. Department of Army are finalizing a perpetual easement agreement. Once the agreement is executed, the ACE will record the document on the DOE's behalf at the local county recorder's office. At that time, the document recordation information will be incorporated into this attachment.

REAL ESTATE FILES

Real estate correspondence and related documents are filed and maintained by the Department of Energy, Albuquerque Operations Office, P.O. Box 5400, Property Management Branch, Property and Administrative Services Division, Albuquerque, New Mexico, (505) 845-6450.

ATTACHMENT 3

GREEN RIVER PERMANENT SITE FILE INDEX

GREEN RIVER PERMANENT SITE FILE INDEX

LICENSING DOCUMENTATION

- A. Long-term surveillance plan (LTSP) (final)
- B. Prelicensing custodial care
- C. U.S. Nuclear Regulatory Commission acceptance of LTSP
- D. General license

DOCUMENTATION OF DOE TITLE/CUSTODY

- A. Documentation:
 - State
 - Federal
 - Tribal
- B. Legal description
- C. Custodial care agreements

NATIONAL ENVIRONMENTAL POLICY ACT (NEPA) DOCUMENTATION

- A. Environmental impact statement/environmental assessment
- B. Record of decision/finding of no significant impact
- C. Additional NEPA documentation
- D. Mitigation action plan

REMEDIAL ACTION DOCUMENTATION

- A. Disposal site characterization report
- B. Remedial action plan/remedial action selection report
 - Concurrence pages (signed)
- C. Draft/final technical evaluation report
- D. Final design for construction
- E. Additional design/construction documents/drawings
- F. Final closeout inspection report

G. Site certification report/package

- U.S. Department of Energy certification/summary
- Final completion report
- Final audit report
- Completion report review
- Certification pages (signed)

AS-BUILT CONSTRUCTION

- Drawings and maps

PHOTOGRAPHS

- A. Construction photographs
- B. Aerial photographs
- C. Closeout/inspection photographs
- D. Verification and orientation/initial precicensing inspection photographs

MONITORING DOCUMENTATION

- A. Active monitoring wells
- B. Location of inactive (abandoned) monitor wells
- C. Monitoring station records
- D. Monitoring reports
- E. Programmatic procedures

AGREEMENTS

- A. Interagency
- B. Individual/private

UPDCC SITE FILE INDEX

ATTACHMENT 4
SITE INSPECTION PHOTO LOG

Photographer: _____
Printed Name

Signature

ATTACHMENT 5
INITIAL SITE INSPECTION CHECKLIST

Initial Site Inspection Checklist for the Green River, Utah, Uranium Mill Tailings Disposal Site

Date of Last Inspection: _____

Reason for Last Inspection: _____

Responsible Agency: _____

Address: _____

Responsible Agency Official: _____

Inspection Start Date and Time: _____

Weather Conditions at Site: _____

Inspection Completion Date and Time: _____

Chief Inspector: _____

<i>Name</i>	<i>Title</i>	<i>Organization</i>
-------------	--------------	---------------------

Assistant Inspector(s): _____

<i>Name</i>	<i>Title</i>	<i>Organization</i>
-------------	--------------	---------------------

<i>Name</i>	<i>Title</i>	<i>Organization</i>
-------------	--------------	---------------------

A. GENERAL INSTRUCTIONS

1. All checklist items must be completed and detailed comments made to document the results of the site inspection. The completed checklist is part of the field record of the inspection. Additional pages should be used as necessary to ensure that a complete record is made. Attach the additional pages and number all pages upon completion of the inspection.
2. Inspectors are to provide an up-to-date resume or vitae for inclusion in the inspection report.
3. Any checklist line item marked by an "*" that is checked by an inspector must be fully explained or an appropriate reference to previous reports provided. The purpose of this requirement is to provide a written explanation of inspector observations and the inspector's rationale for conclusions and recommendations.

*Responsibility for site inspections assigned by DOE UMTRA Project Office, Albuquerque, to DOE Grand Junction Projects Office, November 6, 1990.

Explanations are to be placed on additional attachments and cross-referenced appropriately. Explanations, in addition to narrative, will take the form of sketches, measurements, and annotated site map overlays.

4. The site inspection is a walking inspection of the entire site, including the perimeter and sufficient transects to be able to inspect the entire surface and all features specifically described in this checklist. Every monument, site marker, sign, monitor well, and erosion control marker will be inspected.
5. A set of color print 35-mm photographs is required. For this site, the standard set consists of _____ photographs. In addition, all anomalous features or new features (such as changes in adjacent area land use) are to be photographed. A photo log entry will be made for each photograph taken.
6. Field notes taken to assist in completion of this checklist will become part of the inspection record. No form is specified; the field notes must be legible and in sufficient detail to enable review by succeeding inspectors and the responsible agency.

B. PREPARATION (TO BE COMPLETED PRIOR TO SITE VISIT)

Yes No

1. License (includes long-term surveillance plan) reviewed.
2. Site as-built plans reviewed and base map with copies of the following site atlas overlays obtained:
 - a. Adjacent off-site features and land use; fences, gates, and signs; access roads and paths.
 - b. Survey monuments, boundary markers, site markers, aerial photo ground controls, ground photo locations.
 - c. Monitor wells, site drainage, diversion channels.
 - d. Planned inspection transects and vegetation cover.
 - e. Others.

These overlays will be used to identify site features and record, as appropriate, field data.

3. Previous inspection reports reviewed.
 - a. Were anomalies or trends in modifying processes detected on previous inspections?
 - b. Was a Phase II inspection conducted?
 - c. Was custodial maintenance performed?
 - d. Was contingency repair work done as a result of the Phase II inspection?

Yes No

4. Site custodial maintenance and contingency repair records reviewed.
 - a. Has site contingency repair resulted in a change from as-built conditions?
 - b. Are reviewed as-builts available that reflect contingency repair changes?
5. If required, adjacent property entry approval obtained (attach signed access agreement).
6. Aerial photos, if taken since last inspection, reviewed. For each set, enter date taken, scale, and if interpreted.

<u>Set</u>	<u>Date</u>	<u>Scale</u>	<u>Yes</u>	<u>No</u>
1.	_____	_____	_____	_____
2.	_____	_____	_____	_____
3.	_____	_____	_____	_____

7. Were any of the following suggested by examination of aerial photographs? (If yes, give photo set date and indicate if item noted by interpreter or inspector.):
 - a. Intrusion by man?
 - b. Intrusion by animals?
 - c. Channelized erosion on slopes?
 - d. Change in area drainage?
 - e. Landslides?
 - f. Creep on slopes?
 - g. Obstruction of diversion channels?
 - h. Bank erosion of diversion channels?
 - i. Seepage?
 - j. Cracking?
 - k. Change in vegetative cover?
 - l. Displacement of fences, site markers, boundary markers, or monuments?
 - m. Change in adjacent land use?
 - n. Evidence of tailings exposure or transport?

Yes No

8. From as-builts or subsequent inspection reports, note distance and

azimuth from designated site locations, such as a monument, to adjacent off-site features that could eventually affect integrity of site.

	<u>Off-Site Feature</u>	<u>Site Monument No.</u>	<u>Distance</u>	<u>Azimuth</u>
1.	_____	_____	_____	_____
2.	_____	_____	_____	_____
3.	_____	_____	_____	_____

9. Assemble and check out the following equipment as needed to conduct inspections:

- a. Cameras, film, and miscellaneous support equipment.
- b. Binoculars.
- c. Tape measure.
- d. Optical ranging device.
- e. Brunton compass.
- f. Photo scale stick.
- g. Erasable board.
- h. Plant press, plastic bags for vegetation.
- i. Keys to locks.
- j. Bolt cutters.
- k. Hand lens.
- l. Clipboard.
- m. Others.

C. SITE INSPECTION

- 1. Adjacent off-site features (within 0.25 mi [0.4 km] of site boundary)
 - a. Have there been any changes in use of adjacent areas? (grazing, construction, agriculture)
 - b. Are there any new roads or trails?
 - c. Has there been a change in the position of nearby stream channels?
 - d. Has there been headward erosion of nearby gullies?
 - e. Are there new drainage channels?

Yes No

f. Others?

2. Access roads and paths, fences, gates, and signs. (Section _____)

- a. Is there a break in the fence?
 - b. Have any posts been damaged or their anchoring weakened?
 - c. Is there evidence of erosion or digging beneath the fence?
 - d. Does the gate show evidence of tampering or damage?
 - e. Is there any evidence of human intrusion?
 - f. Is there any evidence of large animal intrusion?
 - g. Have any signs been damaged or removed?
(Number of signs replaced: ____)
 - h. Are access roads and paths passable?
 - i. Others?
3. Monuments and other permanent features. (Section ____)
- a. Have the survey or boundary monuments been defaced or disturbed?
 - b. Have the site markers been disturbed by man or natural processes?
 - c. Do natural processes threaten the integrity of any monument or site marker?
 - d. Have aerial photo ground controls been disturbed?
 - e. Others?
4. Crest (Section ____)
- a. Is there evidence of uneven settling? (depression, scarps)
 - b. Is there cracking?
 - c. Has the outer cover layer been breached?
 - d. Is there evidence of erosion?
(1) By water? (rills, rivulets)
(2) By wind? (pedestal rocks, ripple marks)
 - e. Is the vegetation cover as described in the as-builts?
 - f. Is there evidence of animals burrowing?
 - g. Is there evidence of riprap or gravel deterioration?
 - h. Others?

Yes No

5. Slopes (Section ____)
- a. Is there evidence of gradual downslope movement (creep)?
(terraces, deflection of plants)
 - b. Is there cracking?
 - c. Can depressions or bulges on the slope be seen?

- d. Has the outer cover layer been breached?
 - e. Is there evidence of erosion?
 - (1) By water?
 - (2) By wind?
 - f. Has water runoff become channelized? (rivulets, gullies)
 - g. Is there evidence of seepage? (moisture, color, vegetation)
 - h. Has the vegetation cover changed significantly since the last inspection?
 - i. Is there evidence of animal burrowing?
 - j. Is there evidence of deterioration of riprap or gravel cover?
 - k. Others?
6. Periphery (within site boundaries) (Section ____)
- a. Is there evidence of seepage such as wet areas or localized change of vegetation?
 - b. Is there evidence of sediment transport from the tailings pile by water or wind?
 - c. Is the vegetation cover as described in the as-builts?
 - d. Is the drainage as described in the as-builts?
 - e. Others?
7. Diversion channels (Section ____)
- a. Is there evidence of bank erosion?
 - b. Has the integrity of riprap structures been disturbed by man or natural processes?
 - c. Is there evidence of channel erosion?
 - d. Is there evidence of sedimentation in the channel?
 - e. Is the vegetation pattern in the channels consistent with that shown in the as-builts?
 - f. Is the channel obstructed in any way?
- Yes No
- g. Is there any evidence that the diversion channels are not performing their function?
 - h. Others?
8. Photography (Section ____)
- a. Have all photos required by the site atlas photo overlay been taken?
 - b. Has a photo log sheet been prepared for each roll of film exposed?

- c. Number of rolls of film exposed: _____
 - d. Others?
9. Monitor wells (Section _____)
- a. Have any monitor wells been disturbed by man or natural processes?
 - b. Does any natural process threaten the integrity of any monitor well?
 - c. Are all monitor wells' label plates intact and legible?
 - d. Are all monitor wells capped and locked?
 - e. Others?

D. FIELD CONCLUSIONS

- 1. Is there an imminent hazard to the integrity of the tailings pile?
(Immediate report required)
Person _____
Agency to whom report made: _____
- 2. Are more frequent Phase I inspections required?
- 3. Are existing contingency repair actions satisfactory?
- 4. Is a Phase II inspection required?
- 5. Is a contingency report or custodial maintenance required?
- 6. Rationale for field conclusions:

E. CERTIFICATION

I have conducted a prelicensing inspection of the Green River uranium mill tailings site in accordance with the procedures of the license (includes the site surveillance and maintenance plan) as recorded on this checklist, attached sheets, field notes, photo log sheets, and photos.

Chief Inspector's Signature

Printed Name

Title

Date

ATTACHMENT 6

AGENCY NOTIFICATION AGREEMENTS



MIS/UMT/1292-0075



National Earthquake Information Center World Data Center A for Seismology

Director
(303) 236-1540
Research
(303) 236-4506

U.S. Geological Survey
Box 25046, DFC, MS-967
Denver, Colorado 80225 USA
Telex: (WUTCO) 5106014123ESL UD
FAX: (303) ~~236-1540~~
273-8460

Operations
(303) ~~236-1540~~ 273-8500
QED
(800) 358-2663

December 14, 1992

Albert R. Chernoff
UMTRA Project Manager
U.S. Department of Energy
Uranium Mill Tailings Remedial Action
Project Office
5301 Central Ave. NE, Suite 1720
Albuquerque, NM 87108

Dear Mr. Chernoff:

This letter is to confirm that the DOE Grand Junction Projects Office has been added to our notification list for earthquakes near the following sites:

Green River, UT	39.0 N	110.0 W
"Spook" site, WY	43.2 N	105.6 W
Tuba City, AZ	36.1 N	111.1 W
Shiprock, NM	36.8 N	108.7 W

We have entered the following selection criteria into our notification program:

1. Any earthquake of magnitude 3.0 or greater, within 0.3 degrees (about 20 miles) of any site shown above, or
2. Any earthquake of magnitude 5.0 or greater, within 1.0 degrees (about 70 miles) of any site shown above.

Note that these criteria are slightly different than the ones you requested, but we believe that they will still meet your needs. It was not possible to include your first criterion (any earthquake centered within a 9-mile radius of a site) for two reasons. First, this office does not work events that have magnitudes less than 2.5 on the Richter scale, unless someone has reported that the earthquake was felt. Since the Richter scale is logarithmic, earthquakes of magnitude 0 or even negative (-1.3, -2.3, etc) are possible, but with the station distribution we have it would not be possible for us to locate them. Second, the 9-mile radius, or about 0.1 degrees, is smaller than the location error which may occur for the preliminary locations we will be reporting to you. In fact, our preliminary locations which will be reported to the Grand Junction Projects Office will be reported only to the nearest tenth of a degree of latitude and longitude.

For the sites shown above, we believe that we can locate earthquakes reliably that are above a threshold of magnitude 3.0. We also suggest that if any of your personnel at any of these sites feel an earthquake, they should call our office at (303) 273-8500 and our duty geophysicists will check the event for them. Note that after normal duty hours, there is a recording on this number giving the home phone numbers of the two geophysicists on duty.

We have reduced the magnitude threshold for the last criterion from 6.2 to 5.0 and have increased the maximum radius from 40 miles to 70 miles because large earthquakes are not point sources, but can have rupture lengths of significant size. For example, the Landers, California earthquake on June 28 (magnitude 7.6) had a rupture length of more than 40 miles and the Great Alaska earthquake of 1964 (magnitude 9.2) had a rupture length of about 400 miles. The location we compute for an earthquake is the hypocenter - the place where the earthquake starts. Usually an earthquake will rupture farther in one direction than others from the hypocenter. This means that a magnitude 8 earthquake with a hypocenter 60 miles away from one of your sites may in fact have ruptured directly through the site, depending on the orientation of the fault.

If you have any questions about these criteria, please give us a call.

Sincerely,

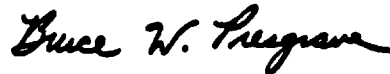

Bruce W. Presgrave
Geophysicist



Department of Energy
 Albuquerque Field Office
 P.O. Box 5400
 Albuquerque, New Mexico 87185-5400

Albert R. Chernoff
 UMTRA Project Manager
 Attention: Steve Hamp
 U.S. Department of Energy
 Uranium Mill Tailings Remedial Action
 Project Office
 5301 Central Avenue, NE, Suite 1720
 Albuquerque, New Mexico 87108

Dear Mr. Chernoff:

This letter is to concur with the U.S. Department of Energy (DOE) request for notification as set forth in the DOE's letter of September 17, 1992. As requested in your letter, this office will contact the DOE's Grand Junction Projects Office at (303) 248-6070 within eight hours of the issuance of a flash flood or tornado warning in either Emery or Grand County, Utah.

Sincerely,

William A. Auler
 Name

Title *Om/MIC*
WSK/SC
 National Weather Service Office
 337 North 2370 West
 Salt Lake City, UT 84116

cc:
 C. Jones, GJPO
 J. Virgona, GJPO
 F. Bosiljevac, UMTRA
 S. Hamp, UMTRA
 E. Artiglia, TAC



Department of Energy
Albuquerque Field Office
P.O. Box 5400
Albuquerque, New Mexico 87185-5400

Albert R. Chernoff
UMTRA Project Manager
Attention: Steve Hamp
U.S. Department of Energy
Uranium Mill Tailings Remedial Action
Project Office
5301 Central Avenue, NE, Suite 1720
Albuquerque, New Mexico 87108

Dear Mr. Chernoff:

This letter is to concur with the U.S. Department of Energy (DOE) request for notification as set forth in the DOE's letter of September 17, 1992. As requested in your letter, this office will contact the DOE's Grand Junction Projects Office if any unusual event or anomaly is observed or reported at the Green River disposal site.

Sincerely,

Name: *Lamar E. Guymon*

Title: *Sheriff*

Emery County Sheriff's Office
P.O. Box 817
Castle Dale, UT 84513

cc:
J. Virgona, GJPO
C. Jones, GJPO
F. Bosiljevac, UMTRA
S. Hamp, UMTRA
E. Artiglia, TAC



MIS/UMT/0293-0021
Department of Energy
Albuquerque Field Office
P.O. Box 5400
Albuquerque, New Mexico 87185-5400

SEP 16 1992

Albert R. Chernoff
UMTRA Project Manager
Attention: Steve Hamp
U.S. Department of Energy
Uranium Mill Tailings Remedial Action
Project Office
5301 Central Avenue, NE, Suite 1720
Albuquerque, New Mexico 87108

FEB 1993
RECEIVED

Dear Mr. Chernoff:

This letter is to concur with the U.S. Department of Energy (DOE) request for notification as set forth in the DOE's letter of September 17, 1992. As requested in your letter, this office will contact the DOE's Grand Junction Projects Office at (303) 248-6070 if any unusual event or anomaly is observed or reported at the Green River disposal site.

Sincerely,

Name: JAMES D. NYLAND, SR.

Title: SHERIFF

Grand County Sheriff's Department
125 East Center Street
Moab, Utah 84532

cc:

C. Jones, GJPO
J. Virgona, GJPO
F. Bosiljevac, UMTRA
S. Hamp, UMTRA
E. Artiglia, TAC

This plate is not available in PDF form

For more information, contact the
U.S. Department of Energy
Grand Junction Office Technical Library
2597 B $\frac{3}{4}$ Road
Grand Junction, Co 81503

970-248-6000