

Alternatives Analysis of Contaminated Groundwater Treatment Technologies Tuba City, Arizona, Disposal Site

February 2015

Prepared By: Golder Associates Inc.
44 Union Boulevard, Suite 300
Lakewood, Colorado, 80228
Project No. 1401485



U.S. DEPARTMENT OF
ENERGY

Legacy
Management

This page intentionally left blank

Contents

Abbreviations	v
Executive Summary	vii
Professional Statement and Qualifications	ix
1.0 Introduction	1
1.1 Project Background	1
1.2 Overview of Existing System	3
1.2.1 Extraction System	3
1.2.2 Treatment System	4
1.2.3 Injection System	5
1.2.4 Evaporation Pond	5
1.2.5 Ancillary Solar Systems	6
1.3 Current Treatment System Operations	6
1.4 Technical Approach to Alternatives Analysis	7
2.0 Evaluation Basis	9
2.1 Influent Design Basis	9
2.1.1 Influent Water Quantity	9
2.1.2 Influent Water Quality	9
2.2 Effluent Treatment Objectives	10
2.3 Summary of Evaluation Basis	11
3.0 Bench-Scale Treatability Study	13
3.1 Treatability Study Overview	13
3.1.1 EC Testing	13
3.1.2 RO Testing	14
3.2 Collection of Bulk Site-Water Samples	14
3.3 Bench-Scale Testing Results	14
3.3.1 EC Testing	14
3.3.2 RO Testing	15
3.3.3 Mechanical Evaporation Testing	18
3.4 Process Modeling	18
3.5 Conclusions	18
4.0 Technology Screening	19
4.1 Reverse Osmosis	19
4.2 Electrocoagulation	20
4.3 Mechanical Evaporation	21
4.4 Passive Solar Evaporation	21
4.5 Enhanced Solar Evaporation	22
4.5.1 Mechanical Sprayers	22
4.5.2 Wetted Floating Fins	22
4.5.3 Wind-Aided Intensified Evaporation	23
4.6 Ion Exchange	23
4.7 Biological Passive Treatment	24
4.8 Technology Screening Summary	25
4.8.1 Reverse Osmosis	25
4.8.2 Electrocoagulation	26
4.8.3 Mechanical Evaporation—Mechanical Vapor Recompression	31
4.8.4 Passive Solar Evaporation	31

4.8.5	Spray-Enhanced Solar Evaporation	32
4.8.6	Wetted Floating Fins	32
4.8.7	WAIV—Enhanced Solar Evaporation	32
5.0	Evaluation of Treatment Alternatives	35
5.1	RO Alternatives	35
5.1.1	Alternative 1A—RO with Pretreatment for Manganese Removal	35
5.1.2	Alternative 1B—RO with IX Softening Pretreatment	40
5.2	Electrocoagulation Alternatives	43
5.2.1	Alternative 2A—EC with RO Polishing	44
5.2.2	Alternative 2B—Standalone EC	47
5.3	Mechanical Evaporation	48
5.3.1	Alternative 3—Mechanical Vapor Recompression Evaporator	51
5.4	Passive and Enhanced Solar Evaporation Alternatives	52
5.4.1	Alternative 4A—Passive Solar Evaporation Ponds	52
5.4.2	Alternative 4B—Enhanced Solar Evaporation Ponds (WAIV)	54
5.5	Estimates of Capital and Operating Expenses	61
5.5.1	CAPEX Estimates	62
5.5.2	OPEX Estimates	63
5.5.3	Life-Cycle Costs	64
5.6	Alternatives Analysis	65
5.6.1	Matrix Criteria Alternative Analysis Results	68
5.6.1.1	Alternative 1A—RO with Manganese Pretreatment	68
5.6.1.2	Alternative 1B—RO with IX Softening Pretreatment	68
5.6.1.3	Alternative 2A—EC with Polishing RO	69
5.6.1.4	Alternative 2B—EC as a Standalone Process	70
5.6.1.5	Alternative 3—Mechanical Evaporation	71
5.6.1.6	Alternative 4A—Passive Solar Evaporation Ponds for Secondary Waste Management	72
5.6.1.7	Alternative 4B—Enhanced Solar Evaporation	73
5.6.2	Alternatives Analysis Weighted Scoring	74
6.0	Conclusions	77
7.0	Recommendations and Path Forward	79
7.1	Path Forward Groundwater Treatment with No Recovery of Treated Effluent	79
7.2	Path Forward Groundwater Treatment Maximizing Recovery of Treated Effluent	80
8.0	References	83

Figures

Figure 1. Site Location Map	2
Figure 2. Block Diagram for Alternative 1A	37
Figure 3. Flow Diagram for Alternative 1B	41
Figure 4. Block Diagram for Alternative 2A	45
Figure 5. Block Diagram for Alternative 2B	49
Figure 6. Block Diagram for Alternative 3	50
Figure 7. Block Diagram for Alternative 4A	55
Figure 8. Proposed Location of New 3-Acre Evaporation Pond	56

Figure 9. Block Diagram for Alternative 4B	57
Figure 10. Typical WAIV Process Installation.....	59

Tables

Table 1. IDB Water Quality Characterization	10
Table 2. Effluent Treatment Objectives and Required Removal Efficiencies.....	11
Table 3. Bench-Scale Treatment Results for EC Influent and Effluent Quality.....	16
Table 4. Bench-Scale Treatment Results for RO Influent, Brine, and Permeate Quality.....	17
Table 5. Technology Summary and Screening	27
Table 6. Alternative 1A RO with Pretreatment for Manganese Removal—Major Equipment List.....	39
Table 7. Alternative 1B RO with IX Softening Pretreatment—Major Equipment List	43
Table 8. Alternative 2A EC with RO Polish—Major Equipment List	47
Table 9. Alternative 2B Standalone EC—Major Equipment List	48
Table 10. Alternative 3 MVR Evaporation with IX Pretreatment—Major Equipment List.....	52
Table 11. Wind-Aided Intensified Evaporation (WAIV) Concept for Groundwater Treatment	60
Table 12. Alternative 4B Wind-Aided Intensified Evaporation (WAIV)—Major Equipment List.....	60
Table 13. Summary of Capital Expense Estimates for Groundwater Treatment Alternatives ...	63
Table 14. Summary of Operating Expense Estimates for Groundwater Treatment Alternatives	64
Table 15. Summary of 10-Year Life-Cycle Cost Analysis for Groundwater Treatment Alternatives	65
Table 16. Analysis Criteria Definitions and Assigned Weights	66
Table 17. Criteria Matrix Scoring Guidance.....	67
Table 18. Matrix Criteria Summary Analysis for Alternative 1A	68
Table 19. Matrix Criteria Summary Analysis for Alternative 1B.....	69
Table 20. Matrix Criteria Summary Analysis for Alternative 2A	70
Table 21. Matrix Criteria Summary Analysis for Alternative 2B.....	71
Table 22. Matrix Criteria Summary Analysis for Alternative 3	72
Table 23. Matrix Criteria Summary Analysis for Alternative 4A	73
Table 24. Matrix Criteria Summary Analysis for Alternative 4B.....	74
Table 25. Ranking of Alternatives, Based on Cumulative Weighted Score.....	74
Table 26. Groundwater Treatment Alternatives Evaluation Matrix	75

Attachments

Attachment A	Site Visit Report
Attachment B	IDB Technical Memorandum
Attachment C	Bench-Scale Test Plan and Bench-Scale Treatability Results Technical Memorandum

This page intentionally left blank

Abbreviations

BADCT	best available demonstrated containment technology
BCR	biochemical reactor
CAPEX	capital expense
CFR	<i>Code of Federal Regulations</i>
CIP	clean-in-place
DC	direct current
DOE	U.S. Department of Energy
EC	electrocoagulation
ft ³	cubic feet
GEMS	Geospatial Environmental Mapping System
Golder	Golder Associates Inc.
gpm	gallons per minute
Hazen	Hazen Research Inc.
HDPE	high-density polyethylene
HMI	human-machine interface
IDB	Influent Design Basis
ISR	in situ recovery
IX	ion exchange
kW	kilowatt
LM	Office of Legacy Management
mg/L	milligrams per liter
micron	1 micrometer
mil	0.001 inch
MVR	mechanical vapor recompression
NPV	net present value
O&M	operations and maintenance
OPEX	operating expense
PLC	programmable logic controller
PV	photovoltaic
RML	Radioactive Materials License
RO	reverse osmosis
SOW	Statement of Work

SPC	sulfide polishing cells
Stoller	The S.M. Stoller Corporation, a wholly owned subsidiary of Huntington Ingalls Industries
TDS	total dissolved solids
TSS	total suspended solids
UF	ultrafilter
WAIV	wind-aided intensified evaporation

Executive Summary

The U.S. Department of Energy (DOE) Office of Legacy Management (LM) is responsible for the Legacy Management Program, which includes the Tuba City, Arizona, Disposal Site (the Site). The S.M. Stoller Corporation, a wholly owned subsidiary of Huntington Ingalls Industries (Stoller), is the Legacy Management Support contractor to DOE and is responsible for operations and maintenance of the current water treatment plant at the Site. The current contaminated groundwater treatment plant consists of a mechanical vapor recompression (MVR) evaporator that was designed and installed more than a decade ago. The treatment technology is approaching its design life and is challenging and costly to operate and maintain, and many of the specialized parts essential to the evaporator process are becoming obsolete and will no longer be manufactured in the near future.

Stoller engaged Golder Associates Inc. (Golder) to provide an alternative analysis of contaminated groundwater treatment technologies for the Site. An alternative analysis of more robust alternative treatment technologies that have matured in the decade since the system was originally designed is required to provide LM managers with potential options that may improve efficiencies, reduce operating and maintenance costs, and meet similar performance objectives. This report evaluates numerous commercially available off-the-shelf technologies including (1) reverse osmosis, electrocoagulation, MVR, and solar evaporation; (2) cost estimates for the design, construction, maintenance, and operation of each technology evaluated; (3) identification of the preferred alternatives through a weighted scoring of technical and economic criteria; and (4) conclusions and recommendations for a path forward on selecting the final technology to implement at the Site.

Enhanced solar evaporation utilizing the wind-aided intensified evaporation process is the highest-rated alternative based on weighted scoring. Enhanced solar evaporation will effectively treat all contaminants, has the lowest estimated life-cycle cost, and is viable at the anticipated flow rates of 40 gallons per minute (gpm) or 100 gpm. However, enhanced solar evaporation does not allow for return of any treated effluent to the aquifer. More complex alternatives using reverse osmosis and MVR as the primary treatment technologies ranked second and third, respectively. Both of these alternatives are projected to produce a treated effluent meeting all treatment objectives, are viable at the anticipated flow rates of 40 gpm or 100 gpm, and return a relatively high recovery of 76 to 90 percent of the treated groundwater to the aquifer.

It is important to note that scoring is subjective and the difference in scores between the top three alternatives is only 10 percent. The results of this alternatives analysis identified several preferred alternatives for replacement of the water treatment system, allowing DOE to select the best technology that balances effluent quality and water-recovery efficiency with treatment cost and complexity.

This page intentionally left blank

Professional Statement and Qualifications

This report constitutes a conventional engineering approach to groundwater treatment alternatives analysis for the Tuba City, Arizona, Disposal Site. It has been developed in a manner consistent with that level of care normally exercised by environmental professionals currently practicing under similar conditions in Arizona and Colorado.

The report was written to fulfill the requirements and objectives of the SOW, subject to the assumptions and reliance on historical information described herein.

The report represents the professional opinion of its authors, and was prepared under the supervision of the following:

Kevin W. Conroy, P.E.

Kevin Conroy has more than 30 years of professional experience, and is a registered Professional Engineer in seven states. He is a Principal in Golder, and is the Water Treatment Practice Leader for the U.S. with responsibility for the strategic and technical direction of water treatment operations. Industrial water treatment services are provided in the areas of manufacturing, food and beverage, remediation, groundwater and leachate, mining, power, oil and gas, and nuclear materials production. Mr. Conroy's entire career has been spent in the field of water management and treatment. He has worked on hundreds of projects that have encompassed a variety of contaminant types including metals, inorganic compounds, high dissolved solids, oil and grease, toxic organic compounds and radionuclides. Project scope has ranged from process development through detailed design, construction and operations. Kevin served as the Lead Professional Engineer for this project, and provided senior review of this submittal.

Signature



Kevin W. Conroy, P.E.
Principal and Water Treatment Practice Leader



This page intentionally left blank

1.0 Introduction

The S.M. Stoller Corporation, a wholly owned subsidiary of Huntington Ingalls Industries (Stoller), as the Legacy Management Support Contractor to the U.S. Department of Energy (DOE) Office of Legacy Management (LM), engaged Golder Associates Inc. (Golder) to provide an alternative analysis of contaminated groundwater treatment technologies for the Tuba City, Arizona, Disposal Site (the Site). The Site location is presented in Figure 1.

This project has been performed in conformance to the Statement of Work (SOW) developed by DOE (DOE 2014). This report documents development of groundwater treatment alternatives and provides path-forward recommendations toward selection of a preferred technology to replace the existing mechanical evaporation treatment process. The technologies to be evaluated as specified in the SOW include solar evaporation, reverse osmosis (RO), electrocoagulation (EC), and one additional commercially available technology to be chosen by Golder. Based upon initial consideration of groundwater quality and effluent treatment objectives and guidance toward commercially available systems, mechanical evaporation was included in the analysis.

Site groundwater is contaminated with uranium and other metals and anions resulting from milling operations in the 1950s and 1960s. Treatment objectives are based on:

- Regulatory requirements in Title 40 *Code of Federal Regulations* (CFR) Part 192 (40 CFR 192), “Health and Environmental Protection Standards for Uranium and Thorium Mills,” Subpart A “Standards for Control of Residual Radioactive Materials from Inactive Uranium Processing Sites”; and
- Non-regulatory objectives which have been agreed to in negotiations with the Navajo Nation.

Groundwater quality and treatment objectives are described in more detail in Section 2.

The primary objective of this alternatives analysis is to identify preferred alternative(s) for replacement of the water treatment system—balancing effluent quality and water recovery efficiency with treatment cost and complexity. The preferred alternative is identified through a weighted scoring of technical and economic criteria which were provided in the SOW and further developed throughout execution of the project.

The balance of this introductory section provides an overview of historic operations and groundwater remediation effort, overview of the existing groundwater treatment plant, and Golder’s technical approach to providing an objective analysis toward identification of a preferred technology for future implementation.

1.1 Project Background

The following project background is paraphrased and condensed from the DOE Fact Sheet for the Site (DOE 2011), and the Groundwater Compliance Action Plan (DOE 1999).

The Site is within the Navajo Nation. A uranium mill was operated from 1956 through 1966, processing approximately 800,000 tons of uranium ore.

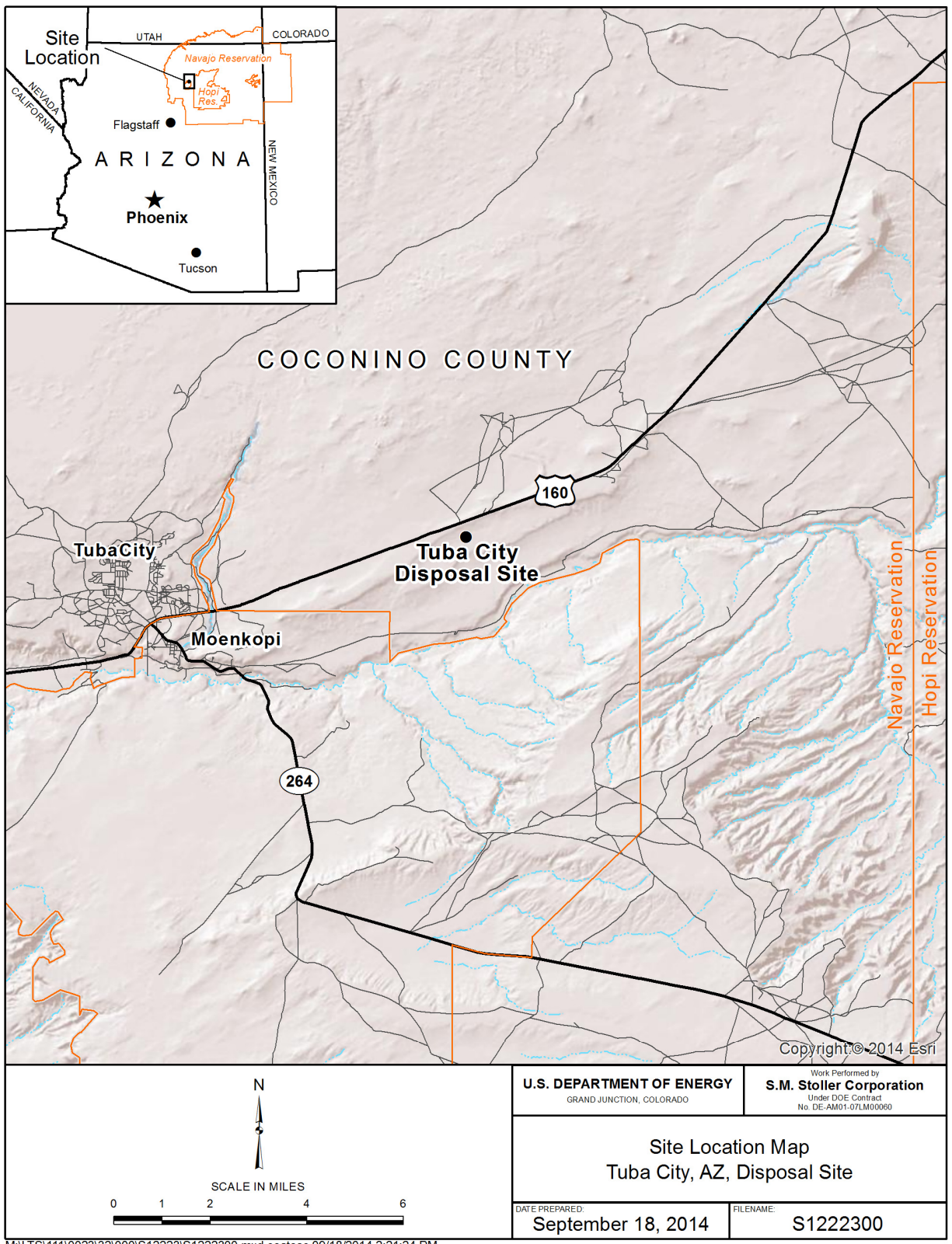

Figure 1. Site Location Map

Mill tailings were a predominantly sandy material with low-level radioactivity. Tailings were conveyed to evaporation ponds as slurry. Surface area of the ponds was 33.5 acres and an additional 250 acres were impacted by windblown tailings. DOE's surface remedial action occurred from 1988 through 1990, consolidating and stabilizing all onsite tailings piles, debris from demolished buildings, and windblown tailings in an engineered disposal cell.

The primary source of groundwater contamination is water that drained from unlined evaporation ponds and infiltrated into the subsurface. Contamination has been detected 2,500 feet hydraulically downgradient in the uppermost part of the aquifer. Contaminants exceeding regulatory standards are molybdenum, uranium, selenium, and nitrate. Restoration goals for chloride, sulfate, and total dissolved solids (TDS) were also established as stakeholder agreements, although these constituents are not regulated under 40 CFR 192.

The groundwater remediation strategy takes a "pump and treat" approach, including groundwater extraction wells, a treatment system, and infiltration of treated effluent. There are 37 extraction wells completed within the contaminated zone of the aquifer. The extraction wellfield was designed to meet objectives of extracting two pore volumes of water from the contaminated plume over a time period of 20 years, and containing the contamination to an area within the existing plume.

Extracted water is treated through ion exchange to remove hardness constituents (calcium and magnesium) and a mechanical evaporation system to remove all contaminants as required by restoration goals established in the Groundwater Compliance Action Plan (DOE, 1999). Treated effluent (condensate from the mechanical evaporator) is returned to the aquifer via an infiltration trench located hydraulically upgradient from the contaminated zone. Secondary wastes (spent ion exchange resin regenerant solution and brine from the mechanical evaporator) are conveyed to a double-lined solar evaporation pond.

1.2 Overview of Existing System

The following overview of the existing treatment system is paraphrased and condensed from the "Treatment System Description Document" (DOE 2012a), as well as 2012 and 2013 Annual Groundwater Reports (DOE 2012b), (DOE 2013) and observations made during the project kickoff site visit (Golder 2014a), which is included with this report as Attachment A.

1.2.1 Extraction System

The extraction system consists of 37 wells. Wells 1101 through 1125 are drilled to a depth of about 250 feet; the screened length in each is about 150 to 157 feet with the exception of well 1116, which is about 195 feet deep with a screened length of 103 feet.

Wells 1126 through 1133 are drilled to a depth of 110 feet and have a screened length of 50 feet. Four former monitoring wells (935, 936, 938, and 942) were converted to extraction wells, with depths ranging from 74 to 96 feet and screened lengths of 20 to 50 feet.

Extraction well pump operation is automatically controlled by the Site's programmable logic controller (PLC). Pumps are turned on and off based on the treatment plant influent feed tank level control signal. Pumps are individually protected from running dry by motor savers, which

automatically shut the pump off when groundwater level drops below the level of the pump inlet. The pump is restarted after a pre-set time interval has elapsed, allowing for recovery of groundwater to a level submerging the pump inlet. In addition to automated controls, each extraction pump can be manually operated by on/off/auto switches in the control room. The extraction system can deliver up to 120 gallons per minute (gpm) to the treatment system.

1.2.2 Treatment System

The original treatment system consisted of a seeded slurry mechanical evaporator with upstream addition of antiscalant and sulfuric acid. Antiscalant was added to minimize build-up of solids on heat-transfer surfaces. Sulfuric acid was added to convert influent carbonate to carbon dioxide to prevent formation of calcium carbonate precipitate within the evaporator. Addition of sulfuric acid was also expected to contribute to formation of calcium sulfate as the main component of the seeded slurry.

The longest continuous run of the evaporator in the first 6 months of operation was 9 consecutive days. Internal scaling and plugging forced shutdowns for cleaning. “The malfunction was caused by uncontrolled formation of calcium sulfate solids, which formed on the heat transfer surfaces, broke off, and plugged the flow channels inside the heat-transfer cartridges” (DOE 2012a). Testing performed from November 2000 through September 2001 confirmed that evaporator cartridges were becoming fouled with calcium sulfate solids, and although many operational modifications were tried, none significantly reduced the fouling tendency. A chemical cleaning regimen was developed, but the required cleaning frequency was deemed to be unacceptable, and an ion exchange (IX) softening process was added upstream from the evaporator.

The IX softening process was installed in 2002 and was designed to remove hardness constituents, primarily calcium and magnesium. Other modifications to improve operational efficiency include:

- Installation of variable frequency drives on process pumps;
- Replacement of a cast iron vacuum pump (which was severely corroded) with a stainless steel pump;
- Removal of the degassifier to eliminate a freeze hazard;
- Increasing the heat transfer area in the distillate cooler to improve energy efficiency;
- Modification to the evaporator level controls to improve reliability;
- Replacement of the vapor cooler with a larger unit to improve vapor handling capacity and energy efficiency;
- Installation of a photovoltaic (PV) array as a source of electrical power for the treatment plant; and
- Installation of a solar concentrator to preheat mechanical evaporator influent.

In its current configuration, the treatment process includes softening, acidification, mechanical evaporation, and condensation. Secondary wastes include spent IX resin regenerant solution and a highly concentrated brine stream from the mechanical evaporator.

According to operating data from June 2008 to present, the evaporation and condensation steps return an average of 87.4 percent of the influent flow as treated effluent in compliance with all regulatory and nonregulatory treatment objectives. The injection system returns condensate to the aquifer.

The IX and mechanical evaporator secondary wastes are conveyed to the solar evaporation pond. The historical (June 2008 to present) average for IX regenerant waste flow to the evaporation pond is about 5.3 percent of the treatment system influent flow. The historical average for brine waste flow from the mechanical evaporator to the evaporation pond is about 7.3 percent (Stoller 2014).

1.2.3 Injection System

The injection system consists of an infiltration tank, infiltration trench, and injection wells. Treated effluent is pumped to the infiltration tank. Water flows from the infiltration tank to the infiltration trench by gravity from an overflow standpipe within the tank at a height of about 10 feet. At this overflow level, the volume of water in the tank is maintained at 63 percent of the tank's capacity.

The infiltration trench is designed to flush treated water under the disposal cell, increasing the movement of contaminated water toward the extraction wells. Treated water is released to the trench through a buried section of perforated pipe. The perforated injection piping has a discharge capacity of 220 gpm.

Six injection wells with a combined capacity of 80 gpm are located approximately 1,500 to 2,000 feet south of the Site's southern fence boundary. Similar to the injection trench, the injection wells are designed to improve extraction efficiency in the contaminated zone and to contain the spread of contamination. The injection wells were tested and proved to be operational but have never been placed into service.

1.2.4 Evaporation Pond

Passive solar evaporation has been utilized at the Site since the inception of the groundwater remediation project. The Final Site Observational Work Plan (Mactec 1998) recommended installation of a spray-enhanced solar evaporation pond. The original design influent flow rate was 115 gpm, which required 43 acres of passive evaporation surface area. To reduce this area, spray-enhanced evaporation was recommended, which resulted in a greatly reduced passive evaporation surface area of 2 acres. However, with an objective to return treated effluent to the aquifer for remediation of the contaminant plume, designs for passive and enhanced solar evaporation (which do not produce a recoverable treated effluent stream) were not pursued.

The Site's existing pond receives secondary wastes primarily as spent IX resin regenerant solution and concentrated brine from the mechanical evaporator and provides volume for accumulation of precipitated solids over the projected 20-year life of the groundwater remediation effort. The pond has approximately 3 acres of evaporation surface area and is double-lined and equipped with sumps to collect and contain any water that seeps through the primary liner. The combined flow rate of mechanical evaporator brine and spent IX regenerant solution is approximately 10 gpm.

The evaporation pond is expected to hold all solids produced throughout the duration of groundwater remediation. Due to the presence of uranium in settled solids, the pond cannot be allowed to run dry. When the summer evaporation rate exceeds inflow of secondary waste into the pond, water can be added directly from the extraction wells. Due to treatment system maintenance and downtime, groundwater has periodically been pumped directly from the extraction wells into the evaporation pond at flow rates up to 100 gpm. The existing pond could receive a 100 gpm flow for a period of 26 to 60 days, depending upon the pond water level when direct inflow is initiated.

When groundwater remediation is complete, the pond solids will be dredged out and disposed of as low-level radioactive waste at the Grand Junction, Colorado, Disposal Site or other licensed appropriate disposal facility.

1.2.5 Ancillary Solar Systems

The solar hot water system consists of parabolic solar concentrating panels, a glycol-water heat exchanger, hot water storage tank, and circulating pumps. The system is designed to heat water to a maximum temperature of 185 °F. Heated water is used to preheat the evaporator influent, resulting in energy savings and improved process efficiency.

The PV array converts solar energy into electrical power and is tied into the Site's power system in the motor control center room. A 51-kilowatt (kW) direct current (DC) system was installed in November 2009 and later expanded in 2013 with an additional 285 kW DC system, for a total capacity of 336 kW DC. The PV system has capacity to provide about 30 to 35 percent of the Site's demand. The PV system is also connected to the local utility power grid, allowing for the sale of any excess power generated during periods of treatment system inactivity.

1.3 Current Treatment System Operations

DOE documents operations of the treatment system in annual groundwater reports. The July 2012 report (DOE 2012b) covers the time frame from April 2011 through March 2012. From April to September 2011, the treatment system was shut down for upgrades and component replacements and then was operated intermittently for a total of 64 days between September 2011 and March 2012. Approximately 9 million gallons of groundwater were extracted for treatment, at an average flow rate of about 97 gpm while the treatment system was operating. Over the course of the full reporting period, the online factor (the amount of time that the plant was operating during the reporting period) was 17.5 percent. The online factor for the operational period from September 2011 through March 2012 (after the extended shutdown for upgrades and component replacements) was about 35 percent.

The August 2013 report (DOE 2013) revealed improvement in treatment system operation, with a total of about 14 million gallons extracted for treatment. "Numerous unplanned shutdowns of the treatment system" occurred in the reporting period, with durations ranging from days to months. The online factor was reported at 31 percent. Despite the low online factors, the quality of treated effluent when the system was in operation met all treatment objectives.

While these reports do not provide details of treatment system operational problems, the low online factors occurring after a significant and lengthy planned shutdown for upgrades are indicative of the system reaching the end of its design life and the necessity for replacement.

1.4 Technical Approach to Alternatives Analysis

Golder's technical approach has been developed around the primary objectives as stated in the Request for Proposal:

- Provide independent analysis of RO, EC, mechanical evaporation, and solar evaporation;
- Provide order-of-magnitude cost estimates for design, construction, maintenance, and operation of each technology; and
- Provide path-forward recommendations toward selection of a preferred technology.

The objectives will be achieved through a combination of bench-scale treatability testing, process modeling, Golder experience with similar water treatment, and literature review.

Following this introductory section, the balance of this report includes:

- Section 2, Evaluation Basis: This section summarizes the Influent Design Basis (IDB) technical memorandum (Golder 2014b), including discussion of how the Geospatial Environmental Mapping System (GEMS) database was used in IDB development. Bounding conditions for influent water chemistry and flow, treated effluent water quality objectives, and water recovery are described.
- Section 3, Bench-Scale Treatability Study: This section presents bench-scale test strategy and results.
- Section 4, Technologies Screening: This section provides process descriptions for EC, RO, mechanical evaporation, and solar evaporation and describes the advantages and disadvantages of the technologies. The existing IX system and several innovative passive treatment technologies are also described. Complete treatment trains (pretreatment, main treatment, polishing treatment, secondary waste handling) are developed as a result of this screening step.
 - Electrocoagulation can be considered as a main treatment process, with no need for pretreatment, but it would require reverse osmosis as a polishing process to meet all treatment objectives.
 - The cost and efficiency of two RO process alternative configurations are discussed. Both RO alternatives include pretreatment to improve the RO's treated effluent recovery rate.
 - Mechanical evaporation: An alternative representing current "state of the art" technology that is more reliable and will require less pretreatment than the existing system will be evaluated.
 - Solar evaporation: The local climate is conducive to maximizing solar evaporation. Passive and enhanced solar evaporation alternatives are evaluated as main treatment alternatives and secondary waste handling (RO brine or mechanical evaporator waste volume reduction).

- Section 5, Alternatives Analysis: Descriptions of alternatives include process narratives, list of major equipment/function, block/process flow diagrams, ancillary equipment, and description of automation/labor requirements. Order-of-magnitude capital expense (CAPEX) and operating expense (OPEX) estimates are presented. Ranking criteria are defined and weighted and the treatment trains are scored to identify a preferred alternative.
- Section 6, Conclusions: Summary results of alternatives analysis, describing the alternative(s) to be carried forward for additional technical study and development of more detailed cost estimates.
- Section 7, Recommendations and Path Forward: Path-forward recommendations include high-level planning for pilot test(s) including scope, expected outcomes, cost of execution, and schedule for the preferred alternative.
- Section 8, References.

2.0 Evaluation Basis

Treatment alternatives must be developed from a common evaluation basis. The evaluation basis includes influent water quality characterization, influent water quantity, and treatment objectives, including water recovery efficiency and water quality characterization for treated effluent. The following sections provide an overview of the influent design basis (quality and quantity of groundwater to be treated), effluent treatment objectives, and resultant contaminant removal efficiencies. Development of the influent design basis was previously reported in a Technical Memorandum (Golder 2014b), which is included with this report as Attachment B.

2.1 Influent Design Basis

The IDB includes consideration of water quantity in terms of flow rate as a nominal range. Operating modes for the treatment system (batch or continuous) may be considered in development of the IDB water quantity parameters. Influent water quality characteristics must also be defined. It is important for the IDB water quality characterization to include all parameters that have treatment objectives as well as parameters that are not regulated but will affect the efficiency of various treatment processes. For example, hardness constituents (calcium and magnesium) are not regulated but will impact the selection of pretreatment processes required for efficient removal of regulated parameters in the main treatment step.

2.1.1 Influent Water Quantity

The IDB water quantity characterization represents the flow-rate flexibility that will be considered in treatment technologies analysis. Two groundwater flow scenarios are developed per the SOW, including:

- Control of plume migration and contamination “hot spots” (lower flow, but higher parameter concentrations); and
- Aquifer restoration (higher flow, lower parameter concentrations).

Continuous flow rates for these two scenarios (as presented in the SOW) are 40 gpm and 100 gpm, respectively, and will be used for treatment equipment sizing and estimation of capital, operating, and life-cycle costs.

Flexibility to operate in continuous or batch mode will also be considered. Continuous flow may be advantageous if the system can be automated for highly reliable unattended operation. A variety of batch flow scenarios, allowing for overnight shutdowns, weekend shutdowns, or both, may be advantageous if the cost of process automation is prohibitive. In order to treat the same volume of water over a time-averaged basis, the batch flow rates would be higher than continuous flow rates.

2.1.2 Influent Water Quality

The IDB water quality characterization is based on site operating data, analytical results from bulk water samples collected for bench scale treatability testing, and historical water quality data from individual monitoring and extraction wells. Comparison and analysis of these three data sets was reported in detail in the IDB Technical Memorandum (Golder 2014b) and resulted in the influent water quality characterization summarized in Table 1.

Table 1. IDB Water Quality Characterization

Parameter ^a	IDB Value
Alkalinity, Total (as CaCO ₃)	420
Ammonia, Total as N	19
Calcium	455
Chloride	100
Iron	0.178
Magnesium	183
Manganese	7.13
Molybdenum	0.218
Nitrate (as N)	577 (130)
Selenium	0.033
Silica	16.4
Sodium	260
Specific Conductance (μS/cm)	3,875
Sulfate	1,600
Total Dissolved Solids	3,550
Uranium	0.556
pH (s.u.)	7.13

Notes:

^a Units are mg/L unless otherwise noted.

Abbreviations:

CaCO₃ = calcium carbonate

μS/cm = microsiemens per centimeter

N = nitrogen

s.u. = standard units

2.2 Effluent Treatment Objectives

The Site groundwater treatment objectives, as documented in the SOW along with removal efficiencies required for compliance, are shown on Table 2. These values include federal regulatory limits from “Health and Environmental Protection Standards for Uranium and Thorium Mill Tailings” (40 CFR 192) and several site-specific effluent treatment objectives.

Table 2. Effluent Treatment Objectives and Required Removal Efficiencies

Parameter ^a	IDB Value	Treatment Objective	Required Removal (%)	Treatment Objective Source
Chloride	100	250	0%	Stakeholder agreement
Molybdenum	0.218	0.1	54%	40 CFR 192
Nitrate (as N)	572 (130)	44 (10)	92%	40 CFR 192
Selenium	0.033	0.01	70%	40 CFR 192
Sulfate	1,600	250	84%	Stakeholder agreement
Total Dissolved Solids	3,550	500	86%	Stakeholder agreement
Uranium	0.556	0.044	92%	40 CFR 192
pH (s.u.)	7.13	6.5–8.5		Stakeholder agreement

Notes:

^a Units are mg/L unless otherwise noted.

Abbreviations:

N = nitrogen

s.u. = standard units

2.3 Summary of Evaluation Basis

The IDB concentrations reflect the current groundwater state and conservatively represent the long-term groundwater condition. Parameters which require treatment include molybdenum, nitrate, selenium, sulfate, total dissolved solids, and uranium. It should be noted that the molybdenum concentrations in the influent are currently below the treatment standard; however, the more conservative molybdenum value has been used to include molybdenum for technology evaluation purposes.

There is also a treatment objective for chloride, which could potentially be exceeded through addition of chloride-containing process reagents. For example, if hydrochloric acid is added for effluent pH adjustment, the chloride concentration would be increased. So, although chloride is not present in groundwater at a concentration requiring removal, its treatment objective concentration is considered in the development of treatment alternatives.

The flow rates as specified in the SOW (40 gpm and 100 gpm) will be used for the IDB. The differences in reported parameter concentrations for the 40 gpm and 100 gpm scenarios will not impact technology screening, the development of treatment alternatives, or their capability to meet the treatment objectives. The water quality differences between the 40 gpm flow scenario and the 100 gpm flow scenario will primarily impact operations costs (chemical reagent consumption, utility power) and will be considered in alternatives cost evaluation. Flexibility for continuous and batch operation will be considered as part of the flow rate IDB. Flexibility over a range of treated effluent recovery efficiencies will also be considered.

This page intentionally left blank

3.0 Bench-Scale Treatability Study

Bench-scale treatability testing primarily focused on the EC process for treatment of the groundwater, but also provided some data on the RO system as well as complete characterization of the groundwater. The following sections provide an overview of the study objectives, execution, and results. Golder prepared a Test Plan (Golder 2014c) and Technical Memorandum (Golder 2014d) to document treatability study results, which are included with this report in Attachment C.

3.1 Treatability Study Overview

EC and RO processes were evaluated through bench-scale testing. Testing was conducted at Hazen Research Inc. (Hazen) in Golden, Colorado, with Golder staff present during testing. Hazen routinely provides industrial research-and-development support for clients in the mineral, chemical, energy, and environmental fields. Hazen holds a Radioactive Materials License (RML), which facilitated expeditious shipping, receiving, testing, and eventually disposal of the bulk water samples from the Site and met Stoller's requirement that testing be performed at a facility that held an RML. Hazen provided two to three lab technicians for execution of the EC and RO trials. Hazen's project manager also witnessed and assisted with the test work.

Powell Water Systems supplied a bench-scale EC unit and provided technical oversight during the EC testing. A single membrane bench-scale RO unit with a new DOW BW30-2540 brackish water membrane was used for RO testing.

Objectives included:

- Development of an influent evaluation-basis water quality characterization. Samples collected simultaneously with the bulk sample (utilized for bench trials) were analyzed for contaminants of concern and other parameters that may impact the treatment efficiency of the technologies under evaluation.
- Determination of the water quality characteristics of RO treated effluent (permeate) and RO brine (reject) streams at a target permeate recovery rate of 70 percent.
- Determination of the water quality achievable through use of EC as a primary treatment process.

3.1.1 EC Testing

The EC testing included the following parameters:

- Reaction times—from 1 minute to 10 minutes.
- Blade types—all iron, all aluminum, and "50/50" combination.
- Influent pH—pH as received, a lower initial pH (5), and a higher initial pH (9).
- Co-treatment reagents—phosphate was added to promote precipitation of ammonia and zinc was added to promote the precipitation of sulfate.

3.1.2 RO Testing

The RO test approach was to operate the RO unit in a recycle mode to achieve a permeate recovery of 70 percent and to develop water quality characterizations for RO permeate and brine streams. It is important to note that the permeate quality characterization from a single run using a new membrane is representative of best-case conditions. Changes in permeate quality over time as the membrane ages and goes through cleaning cycles cannot be projected in a short-duration bench test. No further bench testing is recommended. Should additional test data be required to develop an RO treatment alternative, a long-term pilot study would be required.

3.2 Collection of Bulk Site-Water Samples

Two bulk groundwater shipments were made to Hazen to support two rounds of EC testing and one round of RO testing. Upon receipt of the first bulk shipment (100 gallons shipped in two polydrums) at Hazen, samples were submitted for analysis to provide a baseline water chemistry prior to testing and to establish the representativeness of the sample through comparison with site historical groundwater quality data. Analytical results showed unusually high concentrations of TDS, sodium, and chloride. The cause of these high levels was investigated. It was determined that the sample was drawn at the plant headworks sample port, which should have provided a representative blend of inflows from all extraction wells. However, the extraction well pumps were not operating at the time of sample collection. The sample port was receiving backflow from the Feed Tank and a cross-connection with ion exchange sodium chloride regenerant solution due to a malfunctioning check valve. The elevated concentrations were discussed with the EC subject matter expert, Mr. Scott Powell (Powell Water Systems), and the decision was made to continue with the EC testing. Mr. Powell's opinion was that the high TDS was essentially comprised of "spectator ions," which would not adversely affect the treatment efficiency or the validity of results for contaminants of concern.

RO testing could not be performed with the first bulk sample, as the high TDS was expected to have a significant impact on RO operation and removal efficiency for contaminants of concern. A second 100-gallon bulk sample was collected and shipped to Hazen. The drums were sampled and analytical results showed all parameters to be within an acceptable range when compared to Site historical groundwater data. The second bulk sample was deemed suitable for RO bench-scale testing, a second round EC of trials for validation of EC results from the first bulk sample, and for new trials focusing on removal of nitrogen species and sulfate.

3.3 Bench-Scale Testing Results

Bench-scale treatability testing results were documented in a Technical Memorandum (Golder 2014d), which is included with this report as Attachment C. A summary of significant results is provided in the following sections.

3.3.1 EC Testing

General observations regarding the treated water quality at various EC trial conditions include:

- All of the target metals of concern (molybdenum, uranium, and selenium) are removed to concentrations in compliance with their treatment objectives by the EC treatment with iron blades.
- A reaction chamber retention time of 3 minutes provided optimal removal of contaminants.

- No advantage was observed in trials for influent pH adjustment or for trials involving use of aluminum blades in the EC reaction chamber.
- TDS, chloride, and sulfate removal were not achieved by any of the treatment conditions.
- Some nitrate conversion to ammonia was apparent from decreased concentration of nitrate and increased concentration of ammonia in the EC-treated effluent.
- Effluent pH was higher than influent pH for all trials.
- Removal of parameters that may cause fouling or scaling issues with RO or evaporation treatment such as manganese, silica, and hardness (calcium and magnesium) was achieved.

Round one EC results were used as a guide for the second round of EC testing. No additional trials utilizing aluminum blades were planned, as they did not perform as well as iron blades and increases in aluminum concentration in treated effluent were observed. Influent pH adjustment was not considered further as the pH increase and decrease trials did not effectively change the treatment efficiency.

The second round of EC testing was focused on longer retention times, evaluation of co-treatment reagents for removal of nitrogen species and sulfate, and on verification of first round results using the bulk sample that was representative of site groundwater quality. The second bulk sample had a TDS concentration of approximately 3,400 milligrams per liter (mg/L). This TDS value and all other individual parameter concentrations were reasonably close to their historic average values. Other general observations regarding the second round of EC testing include:

- All metals treatment objectives were achieved at a 3-minute reaction time.
- The treatment objective for nitrate was only met at a 10-minute retention time. Measurements of reaction chamber temperature and pH during the 10-minute retention time trial were indicative of nitrate conversion to ammonia and ammonia release in gaseous form.
- The phosphate addition trials did not show improved removal of nitrogen species.
- TDS and sulfate removal in compliance with treatment objectives were not achieved in any trials. Test conditions 2ECT-13 and 2ECT-14 were included to evaluate the potential for sulfate removal through addition of co-treatment reagents (zinc and lead). Neither trial showed an increase in sulfate removal efficiency.
- Longer reaction times result in a greater generation of secondary waste volume (sludge).

Summary results of EC trials are provided in Table 3. The Technical Memorandum documenting treatability testing results (Golder 2014d) is provided in Attachment C. EC-treated effluent data for all trials in both rounds of EC testing are included with this Technical Memorandum.

3.3.2 RO Testing

A single-membrane bench-scale RO unit was used in RO testing. Brine was recycled until a permeate recovery of 70 percent was achieved. Approximately 50 gallons from the second bulk sample was treated to produce 35 gallons of permeate and 15 gallons of brine. The analytical results for the second bulk sample along with the RO permeate and brine are shown on Table 4.

Table 3. Bench-Scale Treatment Results for EC Influent and Effluent Quality

Parameter ^a	EC Influent ^b	EC Effluent				Treatment Objectives
		1 min. RT ^c	3 min. RT	5 min. RT	10 min. RT	
Bicarbonate (as CaCO ₃)	360	180	9.5	20	5	
Carbonate (as CaCO ₃)	20	20	51	100	36	
Alkalinity (as CaCO ₃)	360	180	61	110	47	
pH (s.u.)	7.19	7.99	9.32	9.39	9.24	6.5–8.5
Conductivity (µS/cm)	3,780	3,590	3,330	3,190	3,240	
TDS	3,400	3,400	2,800	2,600	2,700	500
TSS	20	20	20	20	20	
Fluoride	0.5	0.5	0.5	0.5	0.5	
Chloride ^d	100	100	100	110	140	250
Nitrate (as N)	440 (100)	440 (100)	422 (96)	194 (44)	4.4 (1)	44 (10)
Ammonia (as N)	17	20	32	63	29	
Phosphorus	0.062	0.05	0.05	0.05	0.05	
Sulfate	1,600	1,600	1,500	1,500	1,700	250
Aluminum	0.05	0.05	0.05	0.05	0.05	
Arsenic	0.055	0.002	0.002	0.002	0.002	
Barium	0.037	0.031	0.052	0.072	0.16	
Calcium	480	410	390	350	440	
Iron	0.71	0.1	0.38	0.56	1.6	
Lead	0.0005	0.0005	0.0005	0.0005	0.0005	
Magnesium	180	170	130	83	17	
Manganese	6.5	1.5	0.75	0.54	0.53	
Molybdenum	0.079	0.06	0.0081	0.0038	0.001	0.1
Potassium ^d	9.3	9.4	10	11	15	
Selenium	0.029	0.027	0.0018	0.0013	0.001	0.01
Sodium ^d	280	280	300	320	430	
Strontium	4.1	3.6	3.9	3.5	4.8	
Uranium	0.55	0.4	0.00013	0.00035	0.0001	0.044
Zinc	0.037	0.02	0.02	0.02	0.02	
Silica	15	10	0.17	0.098	0.13	

Notes:

^a Units are mg/L unless otherwise noted.

^b EC Influent water quality was taken from the bulk drum sample drawn immediately before initiation of EC trials on June 3, 2014.

^c Results are reported for trials run with 1-, 3-, 5-, and 10-minute retention times (RT). Iron blades were used in the reaction chamber. Initial pH values for all trials were “as received.”

^d Concentrations of chloride, potassium and sodium increase with retention time. This trend is attributed to ions released from the iron blades in the reaction chamber.

Abbreviations:

CaCO₃ = calcium carbonate

µS/cm = microsiemens per centimeter

N = nitrogen

s.u. = standard units

TSS = total suspended solids

The RO permeate was a high-quality effluent, as indicated by its TDS concentration of 150 mg/L. It met treatment objectives for all parameters with the exception of nitrate and pH. The nitrate result was not unexpected as it is well established that nitrate rejection by RO is typically not as effective as for other ions. RO permeate typically has a lower-than-neutral pH and requires adjustment into neutral range prior to discharge. As shown in Table 4, the RO permeate pH value from Site water is 6 and would require addition of base to raise the pH into the treatment objective range of 6.5 to 8.5. RO permeate pH values approaching the regulatory definition of hazardous are not expected.

Table 4. Bench-Scale Treatment Results for RO Influent, Brine, and Permeate Quality

Parameter ^a	RO Influent	RO Brine	RO Permeate	Treatment Objectives
Total Alkalinity (as CaCO ₃)	350	990	6	
pH (s.u.)	7.2	7.63	5.58	6.5–8.5
Conductivity (µS/cm)	3,890	8,860	170.1	
TDS	3,400	10,000	150	500
TSS	<20	<20	<20	
Fluoride	<0.2	<0.5	<0.1	
Chloride	100	280	3.3	250
Nitrate (as N)	440 (100)	1,144 (260)	66 (15)	44 (10)
Ammonia (as N)	19	42	6	
Phosphorus	0.059	0.58	<0.05	
Sulfate	1,600	4,500	4.3	250
Aluminum	<0.05	<0.05	0.058	
Arsenic	0.052	0.17	<0.002	
Barium	0.039	0.11	0.0013	
Calcium	460	1,200	4.1	
Iron	<0.1	<0.1	<0.1	
Magnesium	170	480	1.3	
Manganese	6.2	18	0.051	
Molybdenum	0.076	0.24	0.001	0.1
Potassium	8.7	23	1.1	
Selenium	0.027	0.078	<0.001	0.01
Sodium	260	720	18	
Strontium	4	11	0.035	
Uranium	0.51	1.4	0.00095	0.044
Silica	15	40	0.33	

Notes:

^a Units are mg/L unless otherwise noted.

Abbreviations:

CaCO₃ = calcium carbonate

µS/cm = microsiemens per centimeter

N = nitrogen

s.u. = standard units

TSS = total suspended solids

Long-term RO performance cannot be reliably tested in a short-duration bench-scale run. Contaminant rejection gradually declines over time as a function of membrane age and frequency of cleaning cycles required, and can only be projected in a pilot study with a duration covering several cleaning cycles. Therefore, the objectives for bench-scale testing of RO were limited: to provide an indication of upper-bound permeate water quality and to establish a benchmark value for permeate recovery efficiency (volume of treated effluent relative to influent flow rate). As noted above, the RO permeate met all treatment objectives with the exception of nitrate and pH, and a permeate recovery of 70 percent was obtained by running the first-pass brine stream through the unit a second time.

3.3.3 Mechanical Evaporation Testing

Performance of boildown testing was considered as a bench-scale method for determination of evaporation process parameters. Some suppliers of mechanical evaporation equipment perform boildown tests in support of conceptual design and budgetary quotations. Due to the requirement that bench-scale test work had to be performed in a facility holding an RML, supplier testing was not possible. Golder obtained a boildown procedure and received a quote from Hazen for the work. However, the consensus opinion developed through contact with multiple suppliers was that the groundwater quality characterization provided an adequate basis for concept development and budgetary cost estimation so that results of a boildown were not needed.

3.4 Process Modeling

Conceptual designs and prediction of treatment efficiencies for RO and IX unit operations were modelled by equipment suppliers in development of their budgetary cost estimates. Calculations for conceptual design and cost estimation of passive evaporation ponds, based on local climate data, were performed by Golder. Modeling results for RO and IX and passive solar evaporation design calculations are discussed in Section 5.

3.5 Conclusions

The objectives for bench-scale treatability testing were met.

- Baseline water quality data was obtained through analysis of the bulk water samples and was shown to be consistent with operational data presented in the SOW (DOE 2014) and with historical data in the GEMS database (DOE undated).
- The treated effluent from RO testing met all treatment objectives with the exception of nitrate and pH. A treated effluent recovery efficiency of 70 percent was achieved by two-pass treatment of RO brine. Prediction of long-term performance of an RO process would require a longer duration test to observe membrane cleaning and replacement cycles. However, the bench-scale analytical results for RO permeate (treated effluent) and brine water quality support the viability of RO for further development of treatment alternatives.
- The treated effluent from EC testing met all treatment objectives with the exception of nitrate, sulfate, and TDS. Treated effluent recovery efficiency was not measured, but it is reasonable to assume that a typical EC recovery of greater than 90 percent can be achieved. The concentration of total suspended solids (TSS) in EC-treated effluent was measured to provide an indication of the volume and mass of metal-oxide and -hydroxide solids (sludge) produced as EC secondary waste. The viability of EC for further development of treatment alternatives was supported by bench-scale test results.

4.0 Technology Screening

Descriptions of RO, EC, and evaporative (mechanical and solar) technologies and the existing ion exchange pretreatment unit are provided in the following sections. Advantages and disadvantages of each technology are summarized and retain/reject screening recommendations are presented. The decision to retain technologies includes consideration of whether the technologies are appropriately applied as pretreatment, main treatment, effluent polishing (post-treatment), or as a method of handling secondary wastes. Innovative passive treatment technologies are also described, although these technologies do not meet the SOW requirement for analysis of “off-the-shelf” commercially available treatment processes. The primary outcome of technology screening is the assembly of complete process trains as treatment alternatives.

4.1 Reverse Osmosis

RO treatment is a high-pressure filtration process that utilizes a series of semipermeable membranes to reject most dissolved ions in a concentrated brine waste stream while producing a nearly demineralized permeate as the treated effluent stream. The volume of the brine stream is typically in the range of 25 to 50 percent of the influent stream volume, but can be as low as 5 to 15 percent of the influent stream volume, depending on influent water chemistry and level of pretreatment. Permeate recovery as a percentage of influent flow can range from 50 to 95 percent depending on influent water quality and whether multiple stages of RO membranes are used.

RO is a relatively nonselective process (treating almost all anions and cations equally) and typically provides a treated effluent stream with 95 to 99 percent removal of influent constituent concentrations. Certain constituents may have a lower rejection rate and may require polishing treatment to meet effluent targets. Ion exchange or subsequent RO stages are frequently used as polishing processes. Nitrate, present in site groundwater at elevated concentrations, is one of the few constituents that exhibit a lower RO rejection efficiency. Typical rejection of nitrate in the range of 60 to 80 percent is obtained with brackish water membranes. The rejection efficiency for all contaminants will decrease with cleaning cycles, and membrane replacement will eventually be required to maintain the quality and recovery of treated effluent.

Pretreatment may be required to remove organic compounds, scaling compounds, or suspended solids which can cause membrane fouling. Antiscalant and pH adjustment components are often also included with an RO system. The Site’s groundwater will require pretreatment to reduce the manganese concentration. Most membrane manufacturers recommend an influent manganese concentration of less than 1 mg/L. Removal of hardness constituents (calcium and magnesium) is not required, but will allow for a higher RO permeate recovery.

RO treatment has limited flexibility with regard to influent water chemistry and flow rate variations. The impact of changes in influent water quality concentrations could have a major impact on the operations reducing permeate recovery and the membrane life. RO throughput turn-up/turn-down flexibility is about ± 25 percent. Should a wider flow-rate range be required, RO flexibility to changing influent flow rates can be improved through installation of parallel treatment units. For example, two parallel RO units with capacities of 50 gpm and 100 gpm would provide for processing of:

- 50 ± 12.5 gpm through turn-up/turn-down operation of the 50 gpm unit alone;
- 100 ± 25 gpm through turn-up/turn-down operation of the 100 gpm unit alone; or
- 150 ± 37.5 gpm through turn-up/turn-down operation of both units simultaneously.

If parallel installation of RO units is necessary to achieve the desired level of flow-rate flexibility, it is important to note that membranes which are taken out of service when one of the parallel units is idled must be properly maintained. Maintenance would include a permeate flush of the membranes for relatively brief shutdowns (2 days or less) or a more rigorous cleaning and storage routine for shutdowns of longer duration.

RO systems are frequently equipped with a clean-in-place (CIP) skid including a cleaning tank and recirculating pump, allowing for membrane cleaning without the need for disassembly of the treatment process unit. The need for a cleaning cycle is indicated by a drop in permeate recovery. Cleaning cycles can be run automatically with the only operator involvement being the initiation of the cleaning routine. CIP cleaning waste solutions can be recycled and reused but will eventually require disposal. Spent CIP cleaning solutions can be disposed in the existing evaporation pond, and will not affect the waste profile from a regulatory point of view.

A typical custom or pre-engineered RO system will be skid mounted and will include the membranes, high pressure feed pump, a pretreatment cartridge filter for TSS removal, and CIP components. Cleaning will degrade the membranes over time and they require replacement on a nonroutine basis.

4.2 Electrocoagulation

Electrocoagulation is the process of destabilizing suspended, emulsified, or dissolved contaminants in an aqueous medium by introducing an electrical current into the medium. The electrical current provides the electromotive force to drive the chemical reactions. When reactions are driven or forced, the elements or compound will approach the most stable state. Generally, this stable state is a solid that is less colloidal, less emulsifiable, or less soluble than the element or compound at equilibrium values. As this occurs, the contaminants form hydrophobic entities, such as precipitates or phase separations, which can easily be removed by a number of secondary separation techniques (Powell undated).

Chemical addition is generally not required and the sludge volumes produced are typically lower than for conventional chemical precipitation/coprecipitation. Separation and management of EC solids are similar to that required for a chemical precipitation system and may consist of clarification, media filtration, or membrane filtration. The EC process is optimized on a site-specific basis by selection of reaction chamber electrode materials (iron, aluminum, titanium, graphite), control of applied amperage, reaction time, and influent pH. EC reaction times are

typically shorter than conventional coagulation or precipitation systems. EC treatment is more flexible with regard to changes in influent water quality and flow rates relative to most competing technologies. The capital cost of the equipment is higher than conventional chemical precipitation, but the operating costs may be lower due to minimal chemical cost and reduced sludge production.

Primary components of an electrocoagulation system are a reaction tank and clarifier. Other process equipment may include feed pumps, prefilters, break tanks, and transfer pumps. Ancillary equipment may include sludge-handling equipment (sludge settling tanks, mechanical dewatering equipment).

4.3 Mechanical Evaporation

The Site currently utilizes a mechanical vapor recompression (MVR) evaporator. The MVR evaporator is a highly energy-efficient evaporation system exploiting mechanical engineering principals of the heat pump. The water vapor (steam) produced by evaporation is recompressed to increase the pressure and therefore the temperature of the steam. The compressed steam is used to heat the influent water prior to being condensed and discharged as treated effluent. In comparison to an evaporator without vapor recompression and preheat processes, the MVR evaporator can be up to 10 times more energy efficient. Due to this intensive heat recovery, the make-up steam consumption for an MVR evaporator is nearly zero and is typically required only for startup.

MVR condensate is virtually contaminant free, while MVR brine will contain virtually the entire contaminant load in a discharge volume of 5 to 10 percent relative to influent flow. Evaporator cleaning frequency and pretreatment requirements will affect the efficiency of treated water recovery.

While the Site's MVR evaporator has been difficult to operate, it is important to note that significant improvements in this technology have been made in the past 15 years and the operational challenges experienced at the Site are not typical of MVR installations.

The equipment that typically comes standard with supply of an MVR evaporator includes preheater (heat exchanger), main evaporator unit, a vapor compressor (or turbofan), a condenser, associated pumps (feed and discharge), and tanks (feed and effluent storage). Ancillary equipment may include influent pH adjustment and antiscalant addition components.

4.4 Passive Solar Evaporation

Solar evaporation ponds are used extensively in industrial settings to reduce water volumes and to manage sludge resulting from treatment or industrial processes. Evaporation efficiency is governed by climatic conditions, influent flow rate, and to a lesser extent, water chemistry. Evaporation ponds are typically sized on an assumption of zero change in water storage on an annual basis. Ions in solution reach higher concentrations as water leaves the pond through the evaporative process and precipitates form in the pond. Steady-state water chemistry in the pond may be at or near saturation for many minerals species. The effective evaporation rate decreases as constituent concentrations increase, which is taken into account in design. Year-round climatic conditions, boundary layer effects at the interface between the pond's water surface and the

atmosphere, influent water chemistry, and available surface area are the primary input parameters for evaporation pond design.

Site water chemistry and sludge characteristics indicate that pond design should follow guidelines of “best available demonstrated containment technology” (BADCT) for process solution ponds (ADEQ undated). BADCT pond design is prescriptive with regard to number of pond liners, types of liners, and leak detection. BADCT guidance recommends installation of an 80-mil (0.080 inch) high-density polyethylene (HDPE) upper liner and 60-mil (0.060 inch) HDPE lower liner, separated by a spacer that transmits water that penetrates the upper liner to a leak detection sump. The leaked water is then pumped back to the pond and volumes recorded. This typical containment design is very similar to the Site’s existing evaporation pond.

Pretreatment of pond influent is not necessary unless there are constituents present, which would require control under air emissions regulations (e.g., volatile organic compounds). Evaporation ponds can serve as the primary treatment system for contaminated water or for management of secondary waste streams from other water treatment processes.

Maintenance is fairly routine (e.g., liner inspection, pump maintenance, freeboard inspection, sampling). In routine operation of a typical evaporation pond, sludge removal is periodically required in order to maintain optimal capacity and operation. Removal of sludge by vacuum truck is recommended to minimize the potential for liner damage. For the Tuba City site, the existing pond was sized for storage of all process-generated sludge until closure of the groundwater remediation project. Sludge will be removed once, at closure.

4.5 Enhanced Solar Evaporation

The rate of evaporation is dependent upon the interface of the pond water surface and the ambient atmosphere. Enhanced solar evaporation techniques rely on increasing the boundary layer interface between water and air, without increasing the physical footprint of the pond. Examples of enhanced solar evaporation systems include mechanical sprayers, wetted floating fins, influent distribution on the pond apron, and wind-aided intensified evaporation.

4.5.1 Mechanical Sprayers

Mechanical sprayers (i.e. Minetek water cannons) increase the air-water interface by spraying water droplets or mist above the pond. Sprayers may be installed in the pond or on the perimeter berm. Automated on/off controls are frequently included to prevent wind-borne overspray. While higher evaporation efficiency rates can be achieved relative to passive solar evaporation, drawbacks include drift and deposition of contaminants beyond the pond, high power use for pumping, and the need to “over-design” the spray system to account for occurrence of automatic shutdowns due to prevailing wind speed or direction.

4.5.2 Wetted Floating Fins

The use of wetted floating fins has been experimentally demonstrated to improve the evaporation rate achievable in comparison with passive solar ponds (Hoque et al. 2010). Floating aluminum fins, covered with a fabric capable of wicking water from the pond surface, are used to increase the effective evaporative surface area. The effects of fin surface area, spacing, type of wicking

fabric, wind speed, and orientation of fins relative to wind direction were studied, and a 24 percent increase in the evaporation rate was documented (Hoque et al. 2010). The experimental work was performed using tap water on a laboratory scale in a wind tunnel. Variables evaluated included water temperature, relative humidity, fin dimensions, orientation with respect to wind direction, and spacing between fins. Although an optimum set of conditions was determined, the laboratory study cannot be correlated directly to actual operation in ambient climatic conditions. High TDS concentrations inhibit evaporation rates, so the reported increase is a best-case scenario for this enhancement technology. Wetted floating fin equipment, while relatively simple to design and fabricate, is not currently commercially available.

4.5.3 Wind-Aided Intensified Evaporation

Wind-aided intensified evaporation units (commercialized as WAIV technology) use a bank of suspended textile sheets, with the influent flow being distributed from the top. Evaporation rate is increased by wind action on the wetted areas of the sheets. Water that does not evaporate while in contact with the sheets is conveyed to the evaporation pond. This system is a relatively low-maintenance enhancement and is most efficient if used in an area with low humidity and steady winds.

Sheets must be cleaned on a weekly to biweekly basis. Depending upon water chemistry, sheets could be cleaned with a sodium chloride solution, similar to the Site's current ion exchange regenerant solution. If acid cleaning is required, the equipment supplier recommends using a 1 percent sulfamic or citric acid solution. The useable lifespan of the sheets is 5 to 7 years (Golder 2014e). Sheets could then be disposed of as a process waste.

4.6 Ion Exchange

IX involves sorption of ionic species from the treated flow on to a fixed resin bed. Ions which are relatively innocuous to water quality are simultaneously released from the resin into the treated flow. Different resins are used for sorption of cationic and anionic species. If both cations and anions are to be removed, resins can be loaded in a single column as a mixed bed, or in separate columns for sequential process steps. IX is commonly used as a water-softening process, removing calcium and magnesium through exchange with sodium ions.

When the IX resin sorption capacity is fully expended, regenerant solution is introduced, which removes all of the sorbed ions in a highly concentrated, small-volume waste stream. Regenerant volume is typically less than 5 percent of the treated flow.

IX is not viable as a main treatment process for the following reasons:

- Because of the exchange process, the TDS concentration in IX effluent may not be significantly reduced.
- Innocuous constituents in groundwater may be preferentially removed, while contaminants of concern pass through with low removal efficiency.
- Specialty resins (ion-selective) could be used to target removal of the contaminants of concern. However, specialty resins can be prohibitively expensive.

IX is viable as either a pretreatment (softening) or polishing process. IX is currently used on the Site as a softening pretreatment to prevent scale formation in the mechanical evaporator. It could also be applicable as a polishing process to remove any constituents that are not fully removed to their treatment objective concentrations in a main (RO, EC, mechanical evaporation) process.

The Site's existing IX system utilizes two columns in a parallel flow configuration. Each column provides 30 cubic feet (ft³) of resin bed volume. A softening resin is used, primarily targeting removal of calcium and magnesium. When operating at 100 gpm, a column is regenerated every 4 to 6 hours, producing approximately 5 gpm of spent regenerant that is disposed in the evaporation pond. Regenerant salt consumption is approximately 50,000 pounds every 2 weeks or 3,600 pounds per day at 100 gpm.

Ion exchange process modeling indicates that the existing system is undersized by approximately 50 percent, which results in the high frequency for resin regeneration. Conceptually, a two-column system designed for one column in operation and one in standby, with an online resin bed volume of 130 ft³, would allow for once-per-day resin regeneration of one column and a 75 percent reduction in regenerant salt use. The reduction in regenerant use is based on regenerating only when the resin in one column is approaching saturation, rather than regenerating on a timed cycle. Design and installation of a new softening system will be preferable to continued use of the existing system in process alternatives which require a softening step.

4.7 Biological Passive Treatment

Biological passive treatment refers to treatment technologies that can be implemented with minimal operations and maintenance (O&M) requirements and typically involve aerobic or anaerobic biological reactions to bind or degrade contaminants. While potentially applicable to treatment of most of the Site's groundwater contaminants, passive treatment does not meet the SOW requirements for technology selection of being available as an "off-the-shelf" product. Development of a passive treatment system for the Site would require extensive bench- and pilot-scale testing and such a system may not be capable of producing a treated effluent in compliance with all treatment objectives. Discussion of passive treatment is limited to presentation in this technology screening section, with the objective of considering innovative methods for future implementation on the Tuba City Site or other legacy sites.

A well-established passive system should function for a period of years with only periodic monitoring and oversight. The low O&M requirements make passive technologies a favorable option on sites with limited power or difficult access. Passive treatment has become a conventional process in the past 10 years at mining sites, particularly closed mines, and other remote locations.

Typical types of passive treatment systems include the following:

- **Biochemical Reactor (BCR):** BCRs rely on naturally occurring biological, chemical, and physical removal mechanisms. Removal of all metals of concern in the groundwater is well proven. Nitrate could also be removed, but would drive the sizing of the system and could present physical space constraints.

- **Sulfate System:** A series of BCRs followed by sulfide polishing cells can be used to achieve sulfate removal. The sulfide polishing cells (SPCs) are lined ponds containing a mixture of iron material to bind the sulfide generated and woodchips acting as spacers to maintain flow through and surface contact with the iron media). A polishing aerobic wetland or other form of oxidation downstream would be required prior to producing a treated effluent in compliance with treatment objectives.
- **Constructed Wetlands:** Wetlands typically include vegetated cells with wetland plant species and free surface water cells, which resemble shallow mixing basins. Typical wetlands are constructed as a series of lined cells with water depths of about 1.5 feet. Trace metal and nutrient (nitrogen) removal in wetlands is well documented; however, design criteria for specific metals removal are best determined for each site through bench-scale or pilot-scale testing. The relatively low velocity flows through a passive wetland treatment system also allow for removal of suspended solids if present. Constructed wetlands treatment is effective for lower flow rate waste streams at remote locations where power and operations personnel are not readily available. Key wetland design parameters are surface area and contact time required to achieve the desired constituent removal level. Routine maintenance activities may be limited to occasional monitoring of the microbial populations and addition of micronutrients. Long-term maintenance includes periodic sludge or solids removal. Wetland sizing will typically take into account the frequency of sludge removal desired.

In each of the passive treatment systems described above, inorganic (metals) contaminants are effectively bound in the substrate material in each cell. Organic and nutrient contaminants can be degraded through biological activity or bound through uptake into wetlands vegetation. BCR, SPC, and constructed wetlands cells are typically designed for a useful life of 10 to 20 years, after which the reactivity and holding capacity for removed contaminants will be exhausted. Disposal of spent substrate and rebuilding of the passive treatment system will be required if remediation efforts continue beyond the design life of the passive treatment system.

Treated effluent from any combination of BCRs, SPCs, and aerobic constructed wetlands could be conveyed by gravity or by pumped flow to an effluent holding pond or tank. A passively treated effluent could require an active polishing process to be fully compliant with all Site treatment objectives, or could be suitable for injection (meeting all treatment objectives) without an additional polishing process. Bench- and pilot-scale studies would be needed to verify that a passive treatment system built within the Site's space constraints can achieve an acceptable level of contaminant removal efficiency.

4.8 Technology Screening Summary

Summary descriptions of treatment technologies, potential vendors, and relative advantages and disadvantages of the technologies are presented in Table 5. An indication of whether the technology should be retained or rejected for use as a pretreatment, main treatment, polishing, or secondary waste technology is provided in the table. The rationale for the decision to retain or reject each technology is summarized below.

4.8.1 Reverse Osmosis

RO is retained as either a main treatment or polishing process. It is rejected as a pretreatment process and as a secondary waste handling-process.

Factors supporting the viability of RO as a main or polishing treatment are:

- Production of a high-quality effluent at a high water-recovery rate, supporting the aquifer restoration scenario;
- Availability as an off-the-shelf, skid-mounted system from multiple suppliers;
- Compatibility with industry standard automation—PLCs, human-machine interfaces (HMIs), and remote monitoring;
- Suitability to automation for unattended operation;
- Reasonable CAPEX and OPEX, generally lower than mechanical evaporation; and
- Applicability as a polishing process for EC-treated effluent, to produce an effluent that is fully compliant with treatment objectives.

RO was rejected as a pretreatment process primarily because it cannot be effectively operated on an influent flow of IDB water due to the manganese concentration.

RO was rejected as a secondary waste handling-process. It is inapplicable to secondary wastes containing precipitated solids or the TDS concentration typical of the brine stream produced by mechanical evaporation.

4.8.2 Electrocoagulation

EC is retained as either a pretreatment or main treatment process. It is rejected as a polishing process and as a secondary waste handling-process.

Factors supporting the viability of EC as a pretreatment or main treatment process are:

- Capability to effectively remove RO fouling/scaling contaminants (viable as RO pretreatment);
- High water recovery rate, supporting the aquifer restoration scenario;
- Treated effluent not able to meet all treatment objectives as a standalone, but can meet treatment objectives if a polishing process is added;
- Operation without chemical reagent addition;
- Availability as an off-the-shelf, skid-mounted system from multiple suppliers;
- Compatibility with industry standard automation—PLCs, HMIs, and remote monitoring; and
- Suitability to automation for unattended operation.

EC was rejected as a polishing process because the high quality of effluent generated by either RO or mechanical evaporation as a primary process would not require a polishing step.

EC was rejected as a secondary waste handling process. It is not an effective treatment for anion removal, thus would not significantly reduce the TDS concentration of secondary waste streams (RO or mechanical evaporator brines). EC as a secondary waste handling process presents no advantages over use of the existing evaporation pond.

Table 5. Technology Summary and Screening

Technology	Description	Example Vendors	Advantages	Disadvantages	Retain as:			
					Pretreat	Main	Polish	Secondary Waste Handling
Reverse Osmosis								
	Produces high-quality treated water using a semipermeable membrane that retains the majority of dissolved ionic constituents while clean water passes through under pressure. Most water treatment applications use thin film-composite membranes provided by Dow, Hydranautics, Osmonics, or others. A typical system consists of membranes, high-pressure pump, 1-micron (1-micrometer) cartridge prefilter, cleaning skid, and antiscalant (chemical) addition. Changes to the technology in the last 10+ years: Cost has become more competitive relative to other water treatment technologies, standard models are now available, process is becoming more commonly used on wastewater and mining water.	Evoqua, GE, Water and Power Technologies (Degremont), Wigen Water, Pall Corporation, Ultura	<ul style="list-style-type: none"> Off the shelf and skid mounted. Highly automated for unattended operation. Simple system consisting of membranes and pump. Lower initial cost and energy usage than mechanical evaporation. High-quality product water that can meet all treatment goals. Modeling programs can be used for system design. 	<ul style="list-style-type: none"> Nitrate will require polishing to consistently meet 10 mg/L treatment objective. Typically lower treated effluent recovery than mechanical evaporator. Manganese pretreatment will likely be required. Limited turn-up/down capability ($\pm 25\%$) unless parallel trains are installed. Pilot studies required to project long-term O&M requirements for membrane cleaning and replacement. 	No	Yes	Yes	No
Electrocoagulation								
	Precipitation of dissolved ionic species is promoted by passing an electrical current through the water to be treated. The current destabilizes the charge on ionic species, allowing them to coagulate into suspended particles that can be removed. The EC unit includes the reaction chamber, sacrificial metal electrodes, and power source. A clarification or filtration process is required to remove metal precipitates and other coagulated materials. Changes to the technology in the last 10+ years: Standard off-the-shelf packaged systems are available. Technology is widely accepted as standard for treatment of oily wastewater and metal finishing wastewater.	Powell Water Systems, Water Tectonics, Kaselco	<ul style="list-style-type: none"> Does not require addition of chemicals. No secondary ions (such as chloride with ferric chloride addition) are added to the water. No chemical reagents required. Skid-mounted, commercially available off-the-shelf packaged systems. Simple bench testing can evaluate numerous test conditions. Can achieve low metals concentration in treated effluent. 	<ul style="list-style-type: none"> Does not achieve removal of anions. Effluent clarification or filtration is required to remove coagulated solids. Long clarifier retention time required to allow for dissipation of entrained gas. Potential for ammonia off-gassing. Relatively expensive capital cost. 	Yes	Yes	No	No
Mechanical Evaporation								
MVR Evaporator	The MVR evaporator design is based on mechanical engineering principles of the heat pump. Water vapor produced by evaporation is recompressed to increase its pressure and temperature. Recompressed vapor is used to preheat evaporator influent by flowing through a heat exchanger, prior to being condensed and discharged as treated effluent. Due to this intensive heat recovery, the make-up steam consumption for an MVR evaporator is nearly zero and is typically required only for startup. Changes to the technology in the last 10+ years: Use of stainless steel heat transfer surfaces rather than plastic cartridges, use of standardized designs and components, change in configuration from compact cartridges to towers, and general improvements in control systems and equipment	RCC (GE), Aquatech, Swenson, Caloris, Aqua-Pure	<ul style="list-style-type: none"> Pre-engineered units are available. Highly automated for unattended operation. High recovery efficiency of high-quality treated effluent. Proven technology with long operational track record of operation on wastewater and product liquids. Low maintenance requirements on standard mechanical systems (pumps, fans, motors). 	<ul style="list-style-type: none"> High capital cost. High utility power demand. May require pretreatment to reduce scaling potential. 	No	Yes	No	No

Table 5 (continued). Technology Summary and Screening

Technology	Description	Example Vendors	Advantages	Disadvantages	Retain as:			
					Pretreat	Main	Polish	Secondary Waste Handling
Solar Evaporation								
Passive	Typical BADCT double-lined process solution evaporation pond. 60 and 80 mil HDPE liners with geonet separation. Leak detection sump and pump.	GSE Inc., Agru America Inc.	<ul style="list-style-type: none"> Common technology. Simple operation and maintenance. Effective for climatic conditions at the Site. Can utilize existing evaporation pond and infrastructure (i.e., twin pond constructed to west of existing pond). 	<ul style="list-style-type: none"> Sludge maintenance and removal. Requires large area for construction. Zero water recovery. High capital cost. Design requires accurate evaporation data or models. 	No	No	No	Yes
Spray (enhanced)	Water is pumped to sprayers located over the evaporation pond. Water droplets/mist evaporate while airborne.	MineTek, SMI	<ul style="list-style-type: none"> Commonly used for water management for numerous industries. Effective for climatic conditions at the Site. Modular design—can add additional sprayers as needed. Sprayers located on edge of evaporation pond for easy access for maintenance. Can increase evaporation rates by up to 35% or greater, depending on the number of sprayers installed. 	<ul style="list-style-type: none"> Potential for fouling due to water quality. Highly mechanical, requiring regular maintenance to operate consistently. Airborne water droplets are likely to drift on windy days. Visible and audible from the highway. Energy intensive. 	No	No	No	No
Wetted floating fins (enhanced)	Aluminum fins or mesh are covered with a wicking material (e.g., cotton) and are installed from just below water surface to a few inches above the water surface. The fins increase surface area available to evaporation and break the boundary layer to reduce inhibition of evaporation.	None known	<ul style="list-style-type: none"> Passive evaporation process, no pumping required. Increase evaporation rates up to 24% based on lab-scale experiments. 	<ul style="list-style-type: none"> No known vendors. Prone to fouling as salts build up on wicking surface. Long-term maintenance is uncertain (e.g., cleaning and fabric replacement frequency). 	No	No	No	No
WAIV (enhanced)	Water is distributed over a series of parallel, hanging textile sheets that increase surface area available for evaporation. The technology is commonly used in conjunction with an evaporation pond.	Lesico Clean Tech	<ul style="list-style-type: none"> Potential for very high evaporation rates. Climatic conditions at the Site are suited to enhanced evaporation. Automated for unattended operation and low maintenance. Can handle high salinity without fouling. Smaller footprint compared to passive evaporation alone. 	<ul style="list-style-type: none"> Newer technology, not demonstrated beyond pilot scale in the United States, although systems have been installed in South Africa, Israel, and Australia. International vendor (Israel). Cleaning will be required on a weekly to biweekly basis and should be verified through pilot testing. Textile sheets will have to be replaced every 5 to 7 years. Materials and design are proprietary, and the sheets are manufactured only in Israel. 	No	Yes	No	Yes

Table 5 (continued). Technology Summary and Screening

Technology	Description	Example Vendors	Advantages	Disadvantages	Retain as:			
					Pretreat	Main	Polish	Secondary Waste Handling
Biological Passive Treatment								
Biochemical Reactors	Anaerobic BCR capable of removing metals and other constituents. Contaminant removal occurs by several mechanisms, including biological reduction, precipitation (sulfides and hydroxides), co-precipitation, and adsorption. BCRs are commonly used in treatment of acid mine drainage. They are generally installed as lined ponds with distribution piping systems, substrate materials, and collection piping systems. A small amount of manure is sometimes used to inoculate a microbial community in the BCR. Organic substrate materials (wood chips, straw, other local organic matter) are used to provide carbon and nutrients to support the microbial community. Limestone is also typically added as a substrate material to provide neutralization capacity and augment alkalinity. Typically requires a wetland or other form of oxidation as a polishing treatment.	Specialty design by engineering firms	<ul style="list-style-type: none"> Accepted technology for metals and nitrate removal. Proven to remove all metal constituents of concern in the Tuba City Site groundwater. One of the few treatment processes for selenium removal from water. Simple, with very low O&M requirements relative to other water treatment technologies. Lower cost and energy usage than active treatment systems. Sustainable system. 	<ul style="list-style-type: none"> Requires bench/pilot testing (minimum of 3 months). Polishing of effluent would likely be required to remove residual biochemical oxygen demand and nutrients. While it can remove TDS and sulfate, will not provide required removal. Space requirements may be prohibitively large for the groundwater flow. 	No	No	No	No
Wetlands	Aerobic wetlands typically include both vegetated cells with wetland plant species and free surface water cells that resemble shallow mixing basins. They are constructed as a series of lined and bermed cells with water depths of approximately 1.5 feet and designed to resemble natural vegetated wetlands. Typically used in combination with BCRs.	Specialty design by engineering firms	<ul style="list-style-type: none"> Accepted and proven technology; however, more common for polishing or municipal applications. Simple with very low O&M requirements relative to other water-treatment technologies. Lower cost and energy usage than active treatment systems. Sustainable system with net negative carbon footprint. 	<ul style="list-style-type: none"> Requires bench/pilot testing (minimum of 6 months). May not provide required removal of all metals. Will not provide required removal of TDS or sulfate. Space requirements may be prohibitively large for the groundwater flow. 	No	No	No	No
Sulfate System	A series of BCRs followed by sulfide polishing cells (SPCs) to achieve sulfate removal. The SPCs are also lined ponds similar to BCRs, but they contain a mixture of iron material (to bind the sulfide generated) and woodchips (provided as spacers for the iron media). Would likely require a wetland or other form of oxidation downstream of the BCRs and SPCs as a polishing treatment.	Specialty design by engineering firms	<ul style="list-style-type: none"> Would provide removal of all metal constituents of concern and nitrate in the Tuba City site groundwater. Would remove sulfate down to required levels. Simple with relatively low O&M requirements relative to other water-treatment technologies. Lower cost and energy usage than active treatment systems. Sustainable system. 	<ul style="list-style-type: none"> Experimental technology. Requires bench/pilot testing (minimum of 6 months). Multiple BCRs and sulfide polishing cells would be required to achieve the sulfate removal required. Would likely still not meet required TDS removal. Polishing of effluent would likely be required to remove residual biological oxygen demand and nutrients. Space requirements may be prohibitively large for the groundwater flow. 	No	No	No	No

This page intentionally left blank

4.8.3 Mechanical Evaporation—Mechanical Vapor Recompression

Mechanical evaporation is retained for consideration as a main treatment process. Factors supporting the viability of mechanical evaporation as a main treatment process are:

- Production of a high-quality effluent at a high water-recovery rate, supporting the aquifer restoration scenario;
- Availability as an off-the-shelf, skid-mounted system from multiple suppliers;
- Compatibility with industry standard automation—PLCs, HMIs, and remote monitoring;
- Suitability to automation for unattended operation; and
- Improvements in mechanical evaporation technology resulting in greater system reliability (uptime).

Mechanical evaporation was rejected for consideration as a pretreatment, polishing and secondary waste handling process. It is not applicable as a pretreatment, as it would produce a high quality treated effluent which would not need further (main or polishing) treatment. It is rejected as a polishing treatment as it would not provide any technical advantages over RO in this role, and would be more costly to operate. Mechanical evaporation as a secondary waste handling process presents no advantages over use of the existing evaporation pond.

4.8.4 Passive Solar Evaporation

Passive solar evaporation is retained only as a secondary waste handling process. It is not applicable as a pretreatment or polishing process. The surface areas required for operation of 40 gpm and 100 gpm passive solar evaporation ponds were calculated utilizing local climate data at 15 acres and 40 acres, respectively. The relatively large footprint requirement(s) make this alternative less feasible for use as a main treatment process for either IDB flow rate for extracted groundwater.

Passive solar evaporation is a well-proven process for secondary waste handling. Secondary waste streams from the existing treatment system (spent IX regenerant solution and brine from the mechanical evaporator) have been effectively handled onsite through use of the existing evaporation pond. Space is available for construction of a twin pond, directly to the west of the existing pond, to accommodate process alternatives that may generate higher quantities of secondary waste than the current system.

The evaporation rate for a passive solar pond system can be increased by distributing influent flow evenly on the pond apron (the lined interior face of the pond berm). Influent distribution on the apron increases the surface area available for evaporation as well as providing some heat transfer from the liner to the influent flow. A relatively small increase in pumping power and a small CAPEX investment in pipe, fittings, and nozzles would be required. The footprint for a new pond could potentially be reduced by retrofitting the existing pond and by installing the new pond with influent apron distribution systems, previously described as an enhanced solar evaporation process. Influent apron distribution is mechanically simple and would be inexpensive to install and operate.

4.8.5 Spray-Enhanced Solar Evaporation

Spray-enhanced solar evaporation is not retained for further consideration. It is not applicable as a pretreatment or polishing process. As a secondary waste handling process, it does not present advantages over passive solar evaporation that would justify its higher CAPEX and OPEX.

Spray-enhanced solar evaporation is a conventional practice on mine sites in dry climates, and off-the-shelf equipment is commercially available. However, as with all passive and enhanced solar evaporation technologies, no treated water would be available for return to the aquifer. Spray-enhanced solar evaporation presents significant disadvantages if implemented as a main treatment process, which outweigh the potential increase in evaporation rate that could be achieved. Disadvantages include:

- Risk of environmental release beyond the Site boundary, due to windborne overspray;
- Use of on/off automation based on measurement of wind speed and direction to prevent windborne overspray, cutting into the potential increase in evaporation rate;
- High TDS and suspended solids concentrations in influent flow presenting maintenance problems related to scale formation and clogging;
- Significant utility power demand for circulation pumping; and
- Noise and visual concerns for passers-by on the highway.

4.8.6 Wetted Floating Fins

Use of wetted floating fins is not retained for further consideration. Its best fit would be as an enhancement to passive solar evaporation as a secondary waste handling process. However, it is unproven beyond laboratory scale and there are no known equipment suppliers. While equipment could be custom-designed and fabricated, it does not fit the SOW requirement for off-the-shelf availability.

4.8.7 WAIV—Enhanced Solar Evaporation

Enhanced solar evaporation utilizing WAIV equipment is retained for consideration as a main treatment process and for secondary waste handling. The significantly increased evaporation rate afforded by WAIV overcomes the Site's space constraint, which preclude the development of a passive solar evaporation option as a main treatment process. WAIV is not applicable as a pretreatment or polishing process.

Factors supporting the viability of WAIV are:

- All treatment objectives can be met (although no treated effluent would be recovered for aquifer restoration);
- Availability as an off-the-shelf, skid-mounted system;
- Wind (detrimental to spray-enhanced evaporation) is beneficial to WAIV operation, increasing the evaporation rate without increasing the risk of environmental release;
- Minimal OPEX increase over passive solar evaporation;
- Minimal operator involvement required for day-to-day operation;

- Significant increase in evaporation rate, making solar evaporation a viable alternative for main treatment of extracted groundwater flow;
- Compatibility with industry standard automation—PLCs, HMIs, and remote monitoring; and
- Suitability to automation for unattended operation.

This page intentionally left blank

5.0 Evaluation of Treatment Alternatives

Based upon the retain/reject screening as described in Section 4, groundwater treatment alternatives have been developed with the scoped technologies (RO, EC, mechanical evaporation, and enhanced solar evaporation) serving as the primary treatment processes and passive solar evaporation serving as an alternative for secondary waste management. Several alternatives have been developed that include pretreatment and polishing treatment to optimize the recovery and quality of treated effluent. Others have been developed to provide slightly lower water recovery efficiencies or a lower level of treated effluent quality, but these alternatives also offer reduced process complexity. A zero water recovery alternative has also been developed. The alternatives provide a range of final dispositions for treated water, allowing analysis of economic, technical, and nontechnical factors in selection of a preferred alternative. The balance of this section provides descriptions of alternatives, capital and operating cost estimates, and a criteria matrix–weighted scoring analysis of the alternatives.

5.1 RO Alternatives

Two alternatives are developed around RO as the primary treatment process. Both alternatives are projected to produce a treated effluent that is fully compliant with all regulatory and nonregulatory treatment objectives. The alternatives differ in their rates of treated water recovery. This difference is primarily due to the extent of pretreatment.

The two alternatives developed around the RO process include the following:

- Alternative 1A uses two-stage RO as the main treatment process, with pretreatment for manganese removal; and
- Alternative 1B uses two-stage RO as the main treatment process, with pretreatment softening and manganese removal.

Both RO alternatives are projected to produce treated effluent that will be in compliance with all treatment objectives. Both have been developed for the 100 gpm (treated water recovery and aquifer restoration) flow rate.

5.1.1 Alternative 1A—RO with Pretreatment for Manganese Removal

A block flow diagram depicting major equipment along with the process flow path for Alternative 1A is shown in Figure 2. Flow paths and equipment associated with process reagent additions and secondary wastes are also shown.

Alternative 1A includes pretreatment for manganese removal through a multimedia filter; treatment for removal of metals, anions, and TDS through a two-stage RO system; and effluent pH neutralization. The RO process will produce an effluent that is fully compliant with treatment objectives. Secondary waste streams include backwash from the pretreatment multimedia filter and concentrated brine from the two-stage RO system. There will also be an intermittent secondary waste stream from maintenance cleanings of the RO membranes. All secondary waste streams will be routed to the existing evaporation pond, without undue impact on operations. These secondary wastes will not introduce new chemistry to the evaporation pond. The long-term plan for dredging and disposal of pond sludge at the conclusion of groundwater

remediation activities will not be affected by the secondary wastes generated by this alternative treatment process.

Pretreatment for Manganese Removal. The multimedia filter is designed for selective removal of manganese from the influent flow. Oxidant (sodium hypochlorite) is fed into the filter to precipitate manganese in oxide form. Solids formed are retained in the filter media and are periodically removed by backwashing. A dual-column unit will be used, allowing for backwash of one unit while the other remains online. Oxidant storage will require installation of a new tank with secondary containment. A 6,000-gallon oxidant storage tank is included in the Alternative 1A concept, and would provide adequate storage for monthly tanker load chemical deliveries. A standard metering pump will be used to deliver oxidant from the storage tank to the multimedia oxidative filter.

Main treatment by RO. The RO system for Alternative 1A will be provided as a vendor package, including prefilter, antiscalant chemical storage and metering pump, high-pressure RO feed pump, first- and second-stage RO units, and a CIP skid for membrane maintenance.

The RO prefilter will protect the RO membranes from becoming “blinded” with fine suspended solids. Solids carried over from the multimedia filter at a size cutoff of 1 micron will be removed by the RO prefilter.

Antiscalant addition will keep scale-forming constituents in solution (e.g., calcium, magnesium, sulfate, carbonate), allowing for their removal to the RO brine stream and keeping the RO membranes scale-free. Antiscalant feed components are relatively simple, with the chemical drum serving as the storage vessel and a conventional automatic metering pump dosing in the antiscalant in proportion to the RO system’s influent flow rate.

Following addition of antiscalant, influent flow will be fed at high pressure into the RO membranes. Projections based on RO process modeling performed by suppliers indicate that the highest recovery of permeate achievable for the primary RO is 77 percent. If operated at a higher permeate recovery, the contaminant concentrations in the brine stream will more rapidly foul the membranes, requiring more-frequent cleaning cycles and shorter membrane life. The polish RO is projected to achieve a permeate recovery of 90 percent, because the majority of the scaling constituents will have been removed by the primary RO.

RO maintenance cleaning. The need to clean RO membranes will be indicated by a decline in permeate recovery. The RO system will be taken offline and a CIP cycle will be initiated. The CIP skid includes storage tanks for cleaning chemicals, a heating element, recycling pumps, and automated controls. Manifold piping will allow for both the primary and polish RO units to be cleaned from a single CIP skid. Once initiated, the CIP cycle is completely automated and requires little operator interface. The CIP cycle introduces a low pH chemical (typically citric acid) for membrane cleaning followed with a high pH chemical to neutralize any residual acid cleaning chemical, and finally a clean water rinse. Chemicals can be reused through several cleaning cycles before requiring disposal and replacement with a fresh supply. Chemicals will be compatible with disposal in the existing evaporation pond.

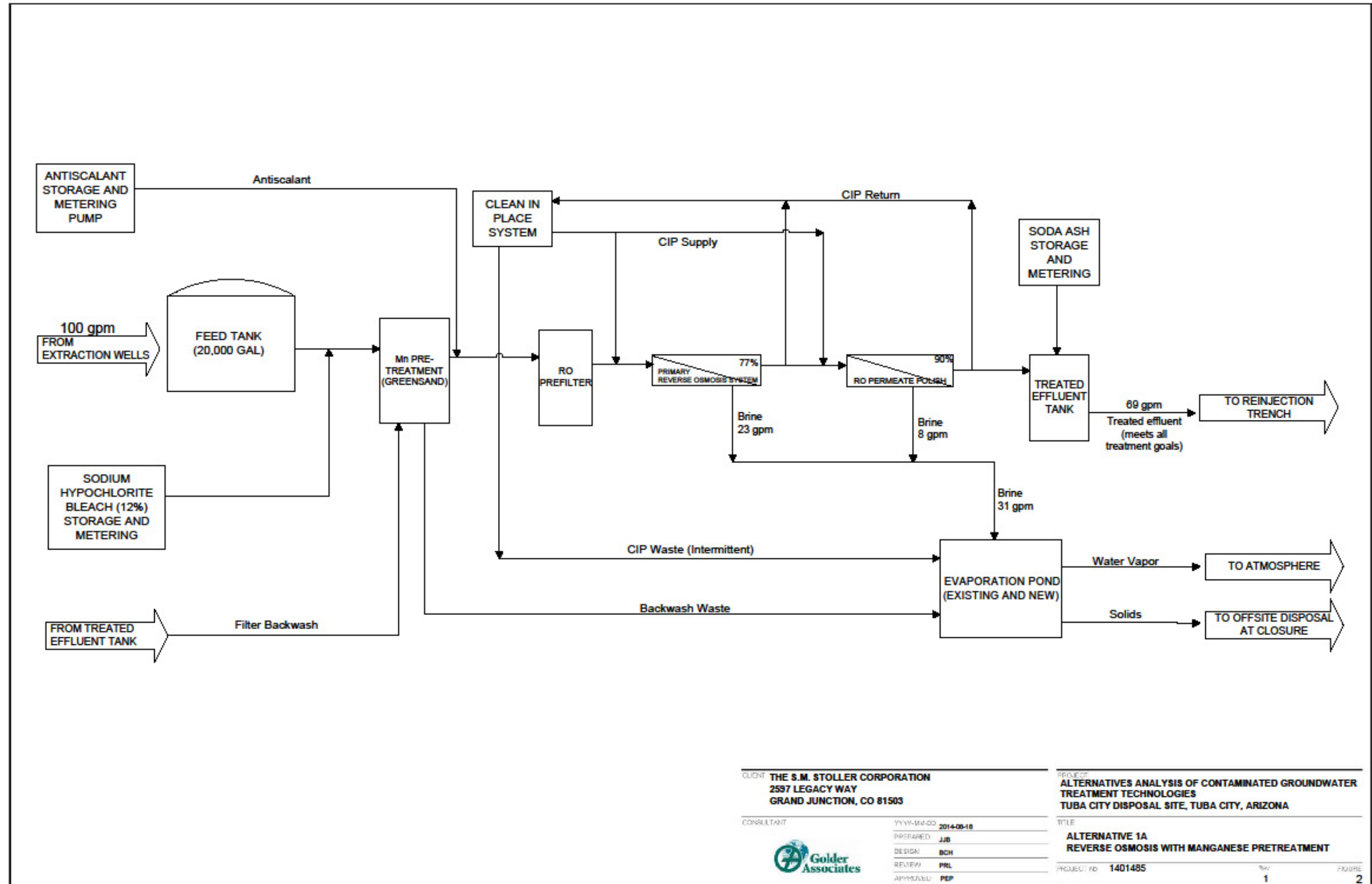

Figure 2. Block Diagram for Alternative 1A

This page intentionally left blank

CIP skids are routinely included in RO vendor-supplied systems. The vendor's standard CIP skid design incorporates safe storage of low pH and high pH cleaning chemicals. The CIP cycle is completely self-contained with chemicals flowing from the CIP skid through the RO membranes and back to the CIP skid. The only potential for operator exposure to chemicals would be when spent chemicals are disposed and fresh chemicals are added. Chemicals to support CIP operation can be safely stored in drums.

Polishing treatment pH adjustment. The pH of RO permeate is projected to be near 6. An effluent neutralization step to bring pH into the range of 6.5 to 8.5 will be required. Soda ash has been selected as the pH neutralization chemical. Soda ash will be received in dry form. A make-down tank to blend dry soda ash into a water solution will be provided. Soda ash solution will then be mixed in the treated effluent tank to meet the effluent pH treatment objective.

Table 6. Alternative 1A RO with Pretreatment for Manganese Removal—Major Equipment List

Item	Name	Description
1	Feed tank – existing	20,000 gal vertical tank with automated level control.
2	Feed pump	100 gpm capacity at 30 feet of head.
3	Manganese pretreatment multimedia filter	Dual columns with manganese removal media, allowing for continuous operation (one column in service while the other is being backwashed).
4	Sodium hypochlorite storage	6,000 gal fiberglass tank compatible with 12 percent sodium hypochlorite. Sized for one tanker delivery per month.
5	Sodium hypochlorite metering pump	Based on IDB flow rate and manganese concentration, a 500 mL/min feed rate is needed.
6	Manganese pretreatment backwash pump	200 gpm backwash pump at 30 feet head. Backwash water will come from treated effluent storage tank.
7	Antiscalant storage and metering	Metering pump feed from drum at mL/min rate. Antiscalant addition equipment will be provided as part of the RO vendor package.
8	RO booster pump	100 gpm at 30 psi feeding into the high-pressure pump on the RO skid.
9	Primary RO unit	Primary RO unit includes 1-micron prefilter, antiscalant addition, high-pressure pump, RO membranes, and CIP skid. Projected permeate recovery is 77%.
10	RO CIP skid	Standard vendor package, including storage for cleaning chemicals, pumps, and automated controls. CIP is a completely self-contained ancillary system. Operator involvement is limited to initiation of cleaning cycle, initiation of normal treatment process operations at completion of cleaning cycle, and occasional chemical drum changeouts.
11	Polish RO unit	90 percent permeate recovery from polishing pass on primary RO permeate.
12	Treated effluent tank	1,100 gal storage tank with mixer, for treated effluent pH neutralization to 6.9.
13	Soda ash storage and metering	Dry soda ash will be delivered in supersacks. Soda ash solution for treated effluent neutralization will be prepared in 2,500 gal batches in a mixing tank, approximately once every 2 weeks for IDB flow rate of 100 gpm.
14	Evaporation pond – existing	10 gpm of RO brine can be routed to the existing pond, plus minimal waste from multimedia filter backwash and RO cleaning cycles.
15	Evaporation pond – new	A new pond approximately 6 acres in area will be constructed to handle 21 gpm of RO brine, bringing the total secondary waste handling capacity (existing and new) to 31 gpm.

Abbreviations:

gal = gallon
mL/min = milliliters per minute
psi = pounds per square inch

The overall recovery of treated effluent for Alternative 1A is expected to be approximately 69 percent. Treated effluent is projected to meet all project treatment objectives. Table 6 provides a list of major equipment, brief descriptions of capacity, and other key features.

5.1.2 Alternative 1B—RO with IX Softening Pretreatment

A block flow diagram depicting major equipment along with the process flow path for Alternative 1B is shown in Figure 3. Flow paths and equipment associated with process reagent additions and secondary wastes are also shown.

Alternative 1B includes pretreatment for removal of hardness constituents (primarily calcium and magnesium); treatment for removal of metals, anions, and TDS through a two-stage RO system; and effluent pH neutralization. The RO process will produce an effluent that is fully compliant with treatment objectives. The two-stage RO system for Alternative 1B is identical to that of Alternative 1A. Secondary waste streams include spent regenerant for the softening pretreatment and concentrated brine from the two-stage RO system. There will also be an intermittent secondary waste stream from maintenance cleanings of the RO membranes. All secondary waste streams will be routed to the existing evaporation pond without undue impact on operations. Secondary wastes from this treatment process will not introduce new chemistry to the evaporation pond and will not affect the long-term plan for dredging and disposal of pond sludge at the conclusion of groundwater remediation activities.

Pretreatment softening. IX softening is the pretreatment step for Alternative 1B. Softening will reduce the scaling potential resulting from high concentrations of calcium and magnesium, allowing for increased RO permeate recovery. The conceptual design for IX equipment is a new two-column unit with larger resin capacity than the Site's existing pretreatment unit. The Site's existing IX columns, at 60 ft³ of resin volume, are undersized for the IDB flow rate and water chemistry, which leads to regeneration cycles occurring every 4 to 6 hours. A conceptual design for a new two-column system with 260 ft³ of IX resin total volume allows for regeneration of one column per day, reducing consumption of regenerant solution and simultaneously reducing the salt load to the existing evaporation pond. The new system will be sized to handle the full IDB flow rate through one column while the second column is being regenerated. A saturated sodium chloride solution will be used for resin regeneration. The existing salt silos and regenerant solution tanks can be utilized with the new IX system. Treated water (approximately 5 gpm) will be recycled back to the NaCl Storage and Feed System to provide water for NaCl solution makedown and column rinses associated with a regeneration cycle. The estimated flow rate of spent regenerant flow is 5 gpm.

Main treatment by RO. The RO equipment description for Alternative 1B is identical to that for Alternative 1A. However, the IX-softened RO feed is projected to yield a 90 percent permeate recovery in the primary RO unit as opposed to 77 percent permeate recovery in the primary RO following pretreatment for manganese removal only.

Similar to Alternative 1A, the polish RO is required for the nitrate removal. A 90 percent permeate recovery is projected for the polish RO (operating on the primary RO permeate), resulting in an overall RO recovery of about 81 percent.

The descriptions of RO maintenance cleaning and polishing treatment and pH adjustment equipment for Alternative 1B are identical to those for Alternative 1A.

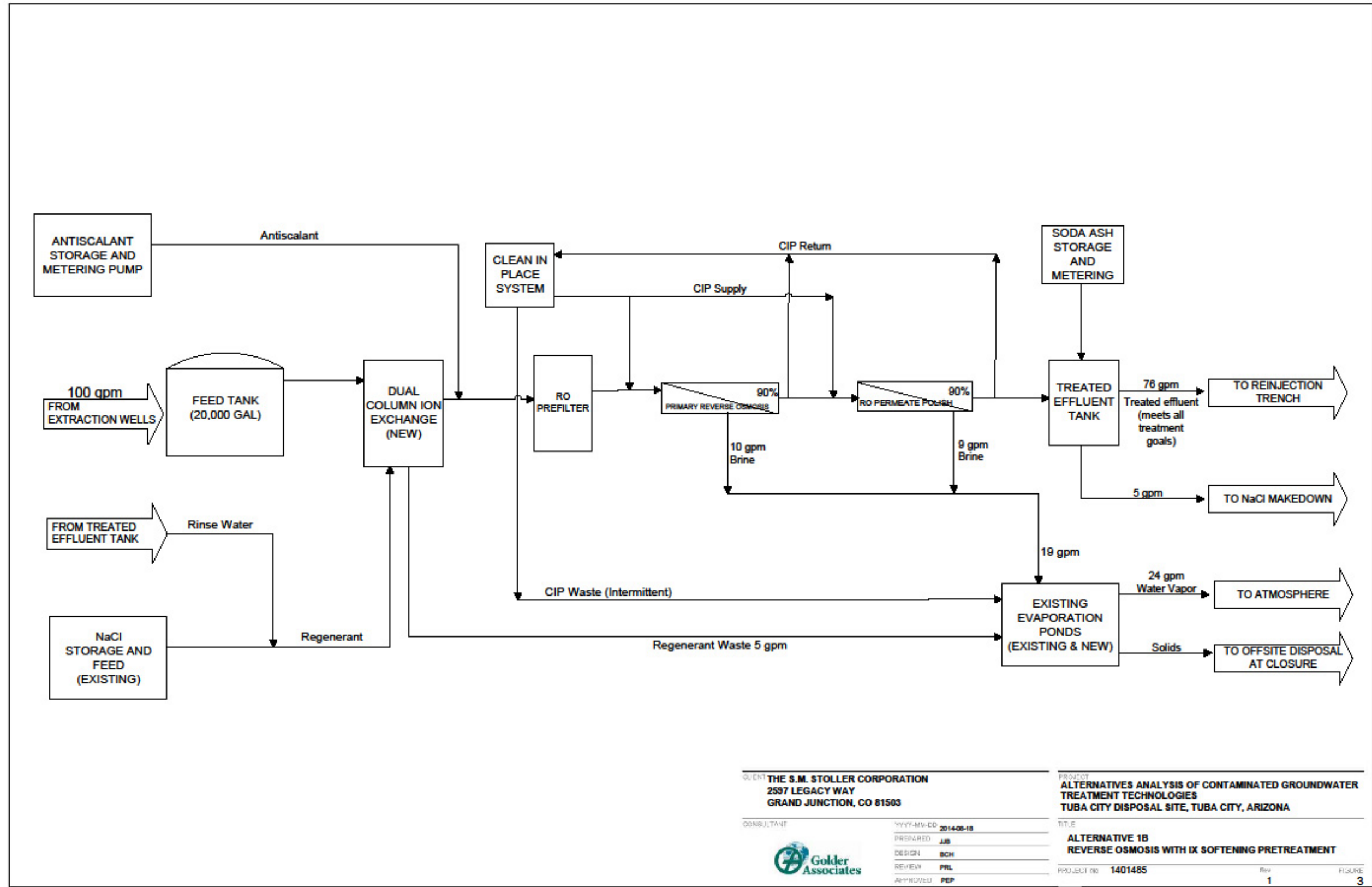

Figure 3. Flow Diagram for Alternative 1B

This page intentionally left blank

The overall recovery of treated effluent for Alternative 1B is expected to be approximately 76 percent, accounting for a 5 gpm secondary waste stream from IX regenerant and a 19 gpm secondary waste stream for the RO system. Treated effluent is projected to meet all project treatment objectives. Table 7 provides an equipment list with general description of the major equipment items.

Table 7. Alternative 1B RO with IX Softening Pretreatment—Major Equipment List

Item	Name	Description
1	Feed tank—existing	20,000 gal vertical tank with automated level control.
2	Feed pump	100 gpm capacity at 30 feet of head.
3	IX pretreatment	52-inch-diameter dual columns with 127 ft ³ of cationic media.
4	Sodium chloride storage and feed	Existing salt silos and regenerant tanks can be used. Salt usage is projected at 715 lb/day to regenerate one column, once per day. Approximately 5 gpm (average) of spent regenerant and rinse water is produced per regeneration cycle.
5	Antiscalant storage and metering	Metering pump feed from drum at mL/min rate. Antiscalant addition equipment will be provided as part of the RO vendor package.
6	RO booster pump	100 gpm at 30 psi feeding into the high-pressure pump on the RO skid.
7	Primary RO unit	Primary RO unit includes 1-micron prefilter, antiscalant addition, high-pressure pump, RO membranes, and CIP skid. Projected permeate recovery is 77%.
8	RO CIP skid	Standard vendor package, including storage for cleaning chemicals, pumps, and automated controls. CIP is a completely self-contained ancillary system. Operator involvement is limited to initiation of cleaning cycle, initiation of normal treatment process operations at completion of cleaning cycle, and occasional chemical drum changeouts.
9	Polish RO unit	90% permeate recovery from polishing pass on primary RO permeate.
10	Treated effluent tank	1,100 gal storage tank with mixer, for treated effluent pH neutralization to 6.9.
11	Soda ash storage and metering	Dry soda ash will be delivered in supersacks. Soda ash solution for treated effluent neutralization will be prepared in 2,500 gal batches in a mixing tank, approximately once every 2 weeks for IDB flow rate of 100 gpm.
12	Evaporation pond—existing	10 gpm of RO brine can be routed to the existing pond.
13	Evaporation pond—new	A new pond approximately 4.5 acres in area will be constructed to handle an additional 9 gpm of RO brine and 5 gpm of IX regenerant, bringing the total secondary waste handling capacity (existing and new) to 24 gpm.

Abbreviations:

gal = gallon
 lb = pounds
 mL/min = milliliters per minute
 psi = pounds per square inch

5.2 Electrocoagulation Alternatives

The EC bench-scale testing demonstrated that removal of all metals of concern could be achieved. Treated effluent was not compliant with treatment objectives for nitrate and sulfate. Two alternatives were developed around the EC process:

- Alternative 2A uses EC as a primary treatment process and includes a polishing step to produce a treated effluent in compliance with all treatment objectives.
- Alternative 2B uses EC as a standalone process, with treated effluent being compliant only with treatment objectives for metals. The sulfate, nitrate, and TDS treatment objectives would not be met.

EC alternatives have been developed for the 100 gpm (treated water recovery and aquifer restoration) flow rate.

5.2.1 Alternative 2A—EC with RO Polishing

A block flow diagram depicting major equipment along with the process flow path for Alternative 2A is shown in Figure 4. Flow paths and equipment associated with process reagent additions and secondary wastes are also shown.

Alternative 2A includes EC, clarification and filtration of EC-treated effluent, and a two-stage RO polishing process.

Electrocoagulation. The EC process will remove metals of concern in compliance with their treatment objectives, and will also remove manganese, calcium, magnesium, and silica, which impact RO operation. The EC reaction chamber will be sized to meet the design basis retention time, and will contain the electrified iron blades, which drive the EC reaction. The electrical power required for EC is 550 amperes, from a 50/60 Hertz, 480-volt 3-phase source, with conversion to DC. Pretreatment for EC is limited to a 0.125-inch screen filter, and no chemical process reagents are required. Iron oxide solids are produced as a secondary waste from the sacrificial consumption of the blades in the reaction chamber. EC-treated water and secondary waste solids are conveyed to the clarification process.

Clarification. The clarification process produces a clear decant and a concentrated secondary waste stream of coagulated solids and metal oxide precipitates (underflow). A conventional gravity-settling clarification process may be used, with a degassing step to reduce clarification retention time. However, a vacuum tower clarifier is frequently used to handle EC secondary waste. Vacuum clarification allows for degasification and solids settling in a single process unit. Components supplied with a vacuum clarifier will include: incoming surge tank, vacuum tower, vacuum pump, sludge pump, and clear water pump. Solids accumulated by vacuum clarification will be in a pumpable slurry form, and can be conveyed to the existing evaporation pond. Flow is projected at about 5 gpm.

Filtration. An ultrafilter (UF)/RO membrane filtration system is used to further treat the vacuum clarifier decant. The UF provides a high-quality feed for the RO, enhancing RO permeate recovery and water quality, while reducing the frequency of RO cleaning cycles. The UF will intermittently produce a secondary waste stream of backwash which will be conveyed to the Site's existing evaporation pond by pumped or gravity flow.

Following the UF, the configuration of RO components for Alternative 2A is identical to Alternatives 1A and 1B.

The RO maintenance cleaning and polishing treatment pH adjustment equipment descriptions for Alternative 2A are also identical to Alternatives 1A and 1B.

The overall recovery of treated effluent for Alternative 2A is expected to be approximately 68 percent. Treated effluent is projected to meet all project treatment objectives.

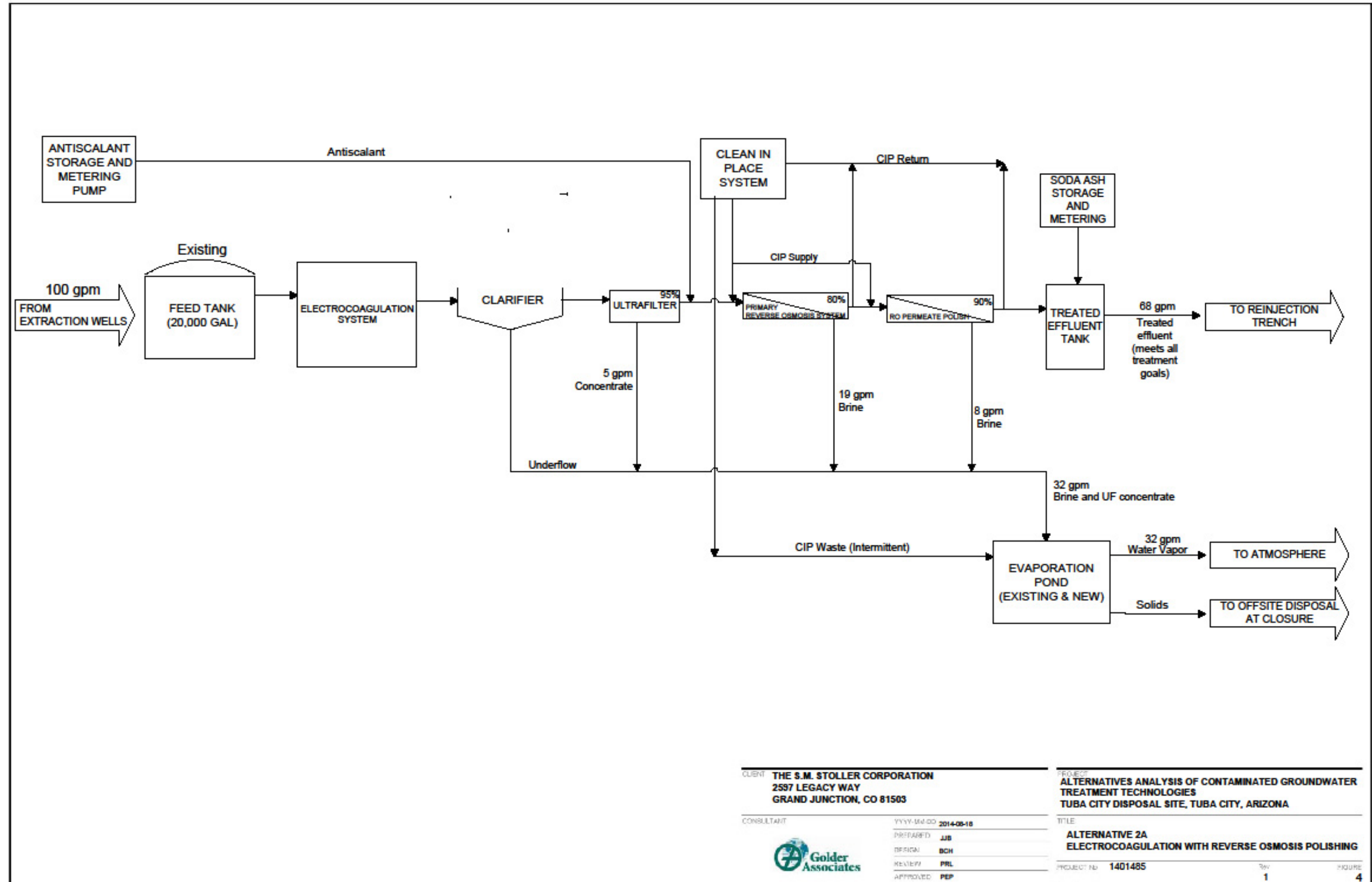

Figure 4. Block Diagram for Alternative 2A

This page intentionally left blank

Table 8 provides an equipment list with general description of the major equipment items.

Table 8. Alternative 2A EC with RO Polish—Major Equipment List

Item	Name	Description
1	Feed tank – existing	20,000 gal vertical tank with automated level control.
2	Feed pump	100 gpm capacity at 30 feet of head.
3	EC unit	Skid-mounted with pump, PLC, current control and polarity reversing capability, automated CIP, 3-minute residence time, sacrificial electrode iron blades.
4	Vacuum clarifier	Includes vacuum pump, break tank, recirculation pump, clear water pump, and vacuum column at 7-foot diameter and 38 feet high.
5	UF	Includes self-cleaning strainers, back-flush and forward flush, air scour, UF membranes, CIP with chemical feed pumps, filtered water storage for RO feed.
6	Antiscalant storage and metering	Feed from drum, metering pump at mL/min flow rate.
7	RO booster pump	100 gpm at 30 psi feeding into the high-pressure pump on the RO skid.
8	Primary RO	Primary RO unit includes 1-micron prefilter, antiscalant addition, high-pressure pump, RO membranes, and CIP skid.
9	UF/RO CIP skid	Standard vendor package including storage for cleaning chemicals, pumps, and automated controls. CIP is a completely self-contained ancillary system. Operator involvement is limited to initiation of cleaning cycle, initiation of normal treatment process operations at completion of cleaning cycle, and occasional chemical drum changeouts.
10	Polish RO	90 percent permeate recovery from polishing pass on primary RO permeate.
11	Soda ash storage and metering	Dry soda ash will be delivered in supersacks. Soda ash solution for treated effluent neutralization will be prepared in 2,500 gal batches in a mixing tank, approximately once every 2 weeks for IDB flow rate of 100 gpm.
12	Treated effluent tank	1,100 gal storage tank with mixer, for treated effluent pH neutralization to 6.9.
13	Evaporation pond – existing	10 gpm of RO brine can be routed to the existing pond.
14	Evaporation pond – new	A new pond approximately 6 acres in area will be constructed to handle 17 gpm of RO brine, and 5 gpm of UF concentrate/vacuum clarifier underflow, bringing the total secondary waste handling capacity (existing and new) to 32 gpm.

Abbreviations:

gal = gallon
mL/min = milliliters per minute
psi = pounds per square inch

5.2.2 Alternative 2B—Standalone EC

A block flow diagram depicting major equipment along with the process flow path for Alternative 2B is shown in Figure 5. Flow paths and equipment associated with process reagent additions and secondary wastes are also shown.

This alternative will utilize the same EC and vacuum clarification equipment as Alternative 2A. Decant from the vacuum clarifier will be filtered through an ultrafiltration unit. Following ultrafiltration, the pH of treated effluent will be adjusted. This alternative is projected to provide the greatest recovery of treated effluent at 95 percent. However, the effluent will not meet the regulatory treatment objective for nitrate, or the nonregulatory (agreement) treatment objectives

for sulfate and TDS. This approach does allow for development of a conceptual treatment train that offers less operational complexity.

Summary equipment descriptions for EC, vacuum clarification, ultrafiltration, and final pH adjustment are identical to Alternative 2A. Secondary waste generated will include settled solids (vacuum clarifier underflow) and a liquid concentrate stream from the UF.

Table 9 provides an equipment list with brief descriptions of the major equipment items.

Table 9. Alternative 2B Standalone EC—Major Equipment List

Item	Name	Description
1	Feed Tank – Existing	20,000 gal vertical tank with automated level control.
2	Feed Pump	100 gpm capacity at 30 feet of head.
3	Electrocoagulation	Skid-mounted with pump, PLC, current control and polarity reversing capability, automated CIP, 3-minute residence time, sacrificial electrode iron blades.
4	Vacuum Clarifier	Includes vacuum pump, incoming surge tank, recirculation pump, clear water pump, and vacuum column at 7 foot diameter and 38 feet high.
5	UF	Includes self-cleaning strainers, back flush and forward flush, and air scour.
6	Soda Ash Storage and Metering	Dry soda ash will be delivered in supersacks. Soda ash solution for treated effluent neutralization will be prepared in 2,500 gal batches in a mixing tank, approximately once every 2 weeks for IDB flow rate of 100 gpm.
7	Treated Effluent Tank	Neutralization to achieve pH treatment objective, 1,100 gal working volume with mixer.
8	Evaporation Pond – Existing	Approximately 5 gpm from clarifier underflow and UF backwash.

Abbreviations:

gal = gallon

5.3 Mechanical Evaporation

The mechanical evaporation treatment technology was selected due to its high-quality treated effluent (distillate) and high recovery efficiency. Mechanical evaporation technology can be expected to produce the greatest volume of treated effluent for return to the aquifer. It is important to note that the operational issues that have resulted in low annual online factors for the existing system are not inherent in all mechanical evaporation systems. The innovative design of the Site’s MVR evaporator, primarily the plastic cartridge heat transfer surfaces, has been the cause of low annual online factors. Conventional MVR evaporator designs are well proven and offer the following advantages over the Site’s evaporator:

- Designs and mechanical components are standardized for off-the-shelf availability with little need for customization to site-specific conditions;
- Heat transfer surfaces are constructed of heat-conductive stainless steel (alloy selected for compatibility with influent water quality);
- Spacing between heat transfer surfaces (tubes or fins) is designed to alleviate clogging due to scale formation;
- Tower configuration is industry standard and eliminates operational challenges (clogging and cleaning) associated with the cartridge configuration.

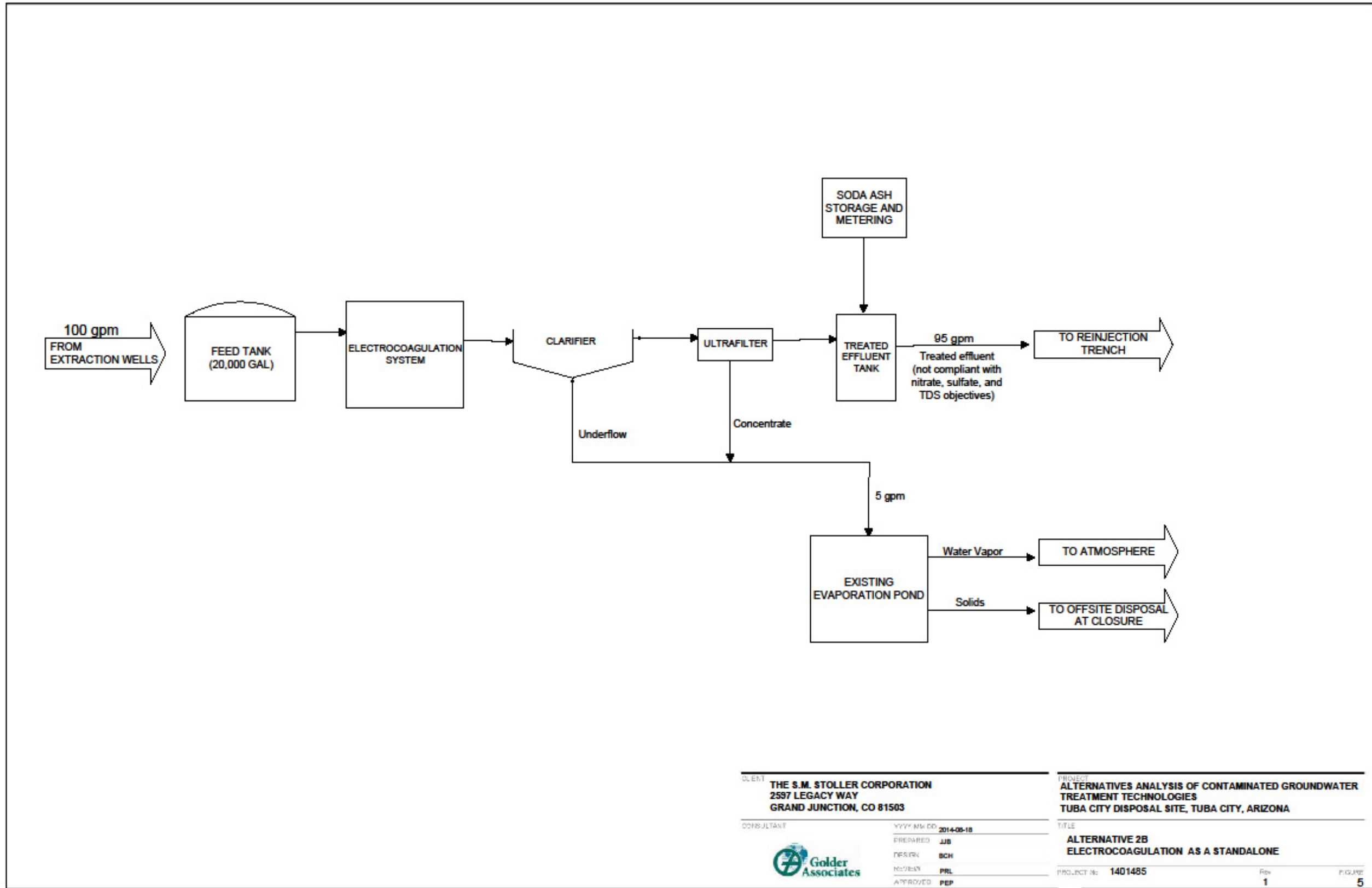

Figure 5. Block Diagram for Alternative 2B

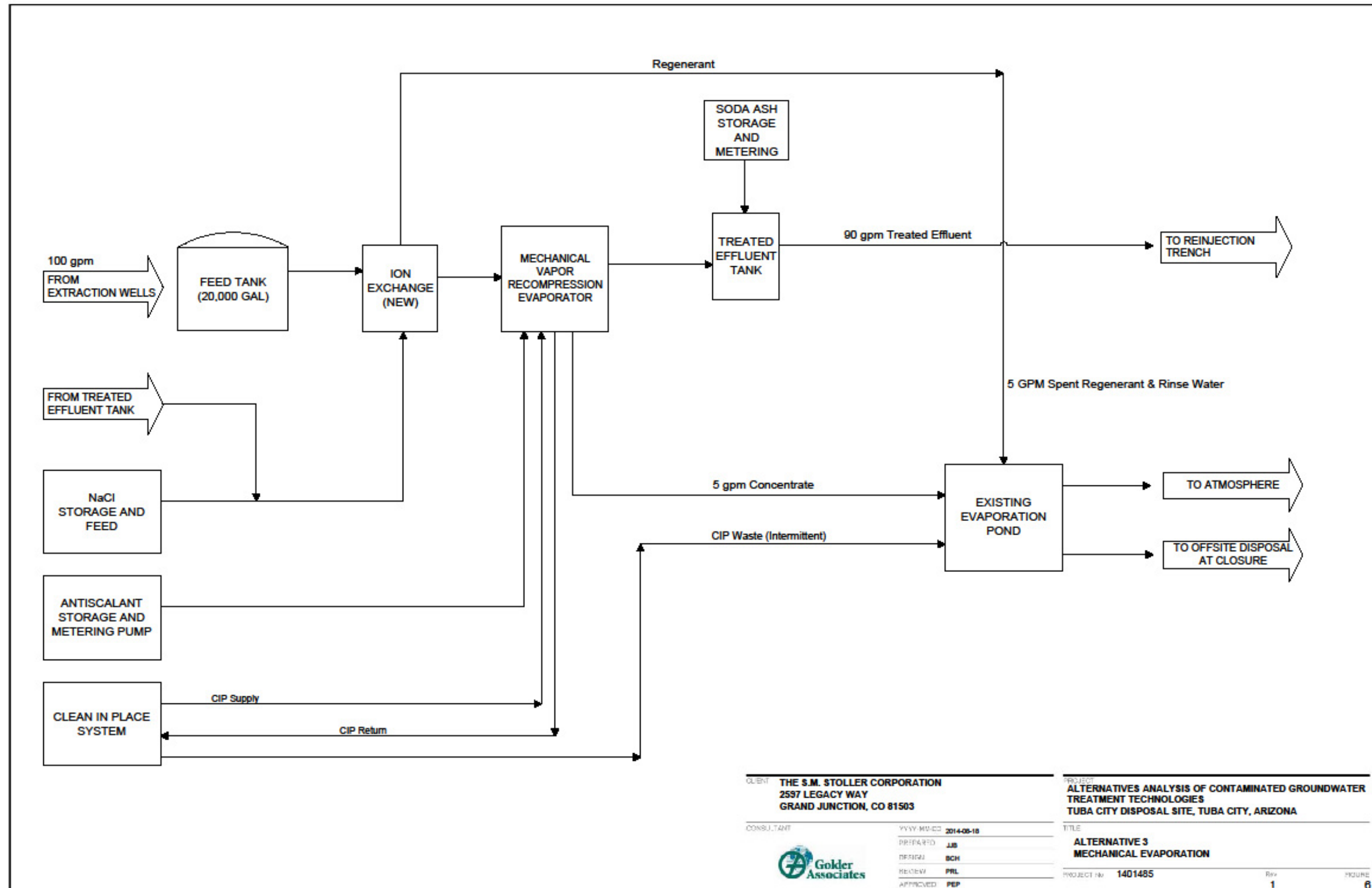

Figure 6. Block Diagram for Alternative 3

In addition to the differences between MVR evaporation designs noted above, there have been significant advances in instrumentation and controls over the past 10 to 15 years, leading to improvement in operational efficiency of MVR evaporation (as well as other process technologies).

Although mechanical evaporators are generally more expensive in initial capital investment and long-term operating costs, the quantity of high-quality effluent produced (along with minimal secondary waste) should also be considered. As the existing system nears the end of its design life, a replacement of evaporation technology has been developed as Alternative 3.

5.3.1 Alternative 3—Mechanical Vapor Recompression Evaporator

A block flow diagram depicting major equipment along with the process flow path for Alternative 3 is shown in Figure 6. Flow paths and equipment associated with process reagent additions and secondary wastes are also shown.

Alternative 3 is a replacement of the existing system. A new IX process (as described in Alternative 1B) is included to reduce scaling potential and optimize evaporator operations efficiency, although equipment suppliers have indicated that operational efficiency of the evaporation process is not dependent on the pretreated quality of evaporator influent. Key differences between the Site's existing mechanical evaporator and evaporators offered by other suppliers include:

- Heat transfer surface area. The existing evaporator has a greater surface area for heat transfer, which minimizes the need to recirculate evaporator brine. However, the spacing between heat transfer surfaces is small and is more inclined to become clogged with scale. New MVR evaporators have less heat transfer surface area, but greater spacing between surfaces. While the brine recirculation flow rate will be higher, the potential to plug the evaporator with scale is greatly reduced.
- Materials of construction and geometry. The heat transfer surfaces in the existing evaporator are constructed of plastic, which is less costly in comparison to stainless steel. Using plastic heat transfer surfaces allows for the evaporator to be configured with a relatively short overall height, with close packing of the plastic sheets. However, as stated above, the spacing between surfaces is suspected as the main cause for scaling, clogging, and downtime for the existing system. New MVR evaporators are configured in much taller columns (up to 40 feet) with either internal stainless steel tubes or fins acting as the heat transfer surface. A downflow configuration is used to achieve thin film evaporation with pumped recirculation of evaporator brine.

Three manufacturers offering MVR evaporation units were contacted. Standard designs and models are commercially available as off-the-shelf systems. The physical configuration of new MVR evaporators is considerably different than the existing unit. It is anticipated that the only major components of the existing system that would be reused are the sulfuric acid storage tank, salt silos and regenerant tanks.

Treated water recovery for Alternative 3 is projected at 90 percent. Treated effluent will be fully compliant with all treatment objectives. Secondary wastes will include IX regenerant and mechanical evaporator brine. Table 10 provides an equipment list with brief descriptions of the major equipment items.

Table 10. Alternative 3 MVR Evaporation with IX Pretreatment—Major Equipment List

Item	Name	Description
1	Feed Tank – Existing	20,000 gal vertical tank with automated level control.
2	Feed Pump	100 gpm capacity at 30 feet of head.
3	IX Pretreatment	52-inch diameter dual columns with 127 ft ³ of cationic media.
4	Sodium Chloride Storage and Feed	Existing salt silos and regenerant tanks can be used. Salt usage is projected at 715 lb/day to regenerate one column, once per day. Approximately 5 gpm (average) of spent regenerant and rinse water is produced per regeneration cycle.
5	Antiscalant Storage and Metering	Feed from drum, metering pump at mL/min flow rate.
6	Evaporator Feed Pump	100 gpm at 30 feet of head.
7	MVR Evaporator	Includes 304 stainless-steel wetted parts, turbofan (or vapor compressor), and air-to-air heat exchanger. Uses Site's existing glycol preheat system to eliminate startup steam.
8	CIP Skid	A vendor-supplied CIP skid will be included with the mechanical evaporator package to allow for acid cleaning of heat transfer surfaces on an as-needed basis. The existing sulfuric acid tank can be used in concert with a new mechanical evaporator's CIP skid.
9	Soda Ash Storage and Metering	Dry soda ash will be delivered in supersacks. Soda ash solution for treated effluent neutralization will be prepared in 2,500 gal batches in a mixing tank, approximately once every 2 weeks for IDB flow rate of 100 gpm.
10	Treated Effluent Tank	pH neutralization to 6.9, 1,100 gal working volume with mixer.
11	Evaporation Pond – Existing	Same volume (10 gpm) to pond as existing system, but with a lower solids load due to reduced IX spent-regenerant flow.

Abbreviations:

gal = gallon
 lb = pounds
 mL/min = milliliters per minute

5.4 Passive and Enhanced Solar Evaporation Alternatives

In the technology screening, passive solar evaporation was retained as a secondary waste-handling process. Enhanced solar evaporation was retained for treatment of the full design basis flow. The following solar evaporation alternatives have been developed:

- Alternative 4A provides for passive solar evaporation of secondary waste streams resulting from mechanical treatment processes (RO or mechanical evaporation brine streams, spent regenerant from IX, spent cleaning solutions, and filter backwashes). The existing evaporation pond will be utilized for secondary waste flows, which are projected to be less than or equal to the current inflow. Additional pond capacity is considered for processes projected to generate greater quantities of secondary waste flow.
- Alternative 4B utilizes enhanced solar evaporation, and is conceptualized with capability to treat either IDB flow rate of 40 gpm or 100 gpm.

5.4.1 Alternative 4A—Passive Solar Evaporation Ponds

Passive solar evaporation was developed as an alternative for secondary waste management to handle flow rates ranging from 5 to 32 gpm. This flow rate range is representative of the projected secondary waste flows from alternatives including primary treatment by RO, EC, and mechanical evaporation. A block flow diagram for Alternative 4A is provided as Figure 7.

The existing solar evaporation pond has a capacity of approximately 10 gpm for continuous flow on an annualized basis. In summer months, groundwater is sometimes pumped directly into the pond to prevent it from going completely dry, which could lead to airborne spread of contaminants concentrated in pond sludge. Conversely, in winter when the natural evaporation rate is reduced, the pond level typically increases. Pond level must be seasonally managed to avoid both extremes (running dry in the summer or overflowing in the winter). For alternatives projected to generate secondary waste flows less than or equal to the existing system (Alternatives 2B and 3), the existing pond can be used with no need for modification or expansion. For alternatives projected to generate greater flow of secondary wastes (Alternatives 1A, 1B, and 2A), a new pond will need to be constructed to be used in parallel with the existing pond.

Local climate data (from Tuba City [NOAA 2014] and Winslow, Arizona [NOAA 2014, ADWR 2011]) were used to estimate evaporation rates at the Site. Parameters included in the Winslow dataset allowed for calculation of a Penman-Monteith evaporation rate, based on monthly solar irradiance, maximum and minimum temperatures, relative humidity, and wind speeds (Snyder and Eching 2006). The results of this analysis indicate potential for year-round evaporation at rates ranging from 0.22 to 1.06 feet per month, and an annual total evaporation potential of 7.39 feet. Site data includes weekly inflows to the evaporation pond and for the time period from April 2013 to April 2014, weekly flow averaged of 83,000 gallons, resulting in an annual average flow of about 8.3 gpm into the 3-acre pond. Pond levels are not recorded simultaneously with weekly flow volumes, so the Site's historical annual evaporation potential cannot be determined from the data that is routinely collected.

Sizing of passive solar evaporation ponds also takes annual rainfall and the TDS concentration of influent flow into account. Extreme storm events are accounted for in the design of pond freeboard height, to ensure that the pond will not overflow. Conceptual design of a passive solar evaporation pond for an influent flow rate of 10 gpm, including consideration of TDS concentration and capacity for storm events, resulted in total surface area of approximately 3.9 acres. The conceptual design of a 3.9-acre pond for a 10 gpm capacity is based on conservative assumptions (greater freeboard, and a lower evaporation rate than indicated by historical Site operations) and it is possible that a twin 3-acre pond could increase the Site's passive solar evaporation capacity to 20 gpm.

Construction of an additional twin pond immediately to the west of the existing pond could increase the evaporation capacity to about 20 gpm of continuous flow (Figure 8). Should one of the RO alternatives (1A or 1B) be selected for additional feasibility-level study and design, enhanced solar evaporation or additional footprint for passive solar evaporation may be required to handle the secondary waste flows (31 gpm for Alternative 1A or 24 gpm for Alternative 1B).

The conceptual design for installation of additional passive solar evaporation capacity includes:

- Double geomembrane liners: 80 mil upper, geonet liner spacer, 60 mil lower liner;
- Leak-detection sump and pumping system;
- 1.5 percent grade for the bottom surface toward the sump;
- 10 feet of height from bottom of pond to top of berm;
- 3:1 slopes from bottom of the pond to the top of berm;

- 2 feet by 2 feet anchor trench for geomembrane stability;
- 15 foot berm width;
- 4:1 slopes from top of berm to existing grade; and
- Bottom of pond at 7 feet below existing grade with berm at 3 feet above grade.

Conservative design assumptions have been made in the conceptual sizing of passive solar evaporation ponds for Alternative 4A, thus higher influent rates may be possible. Eight additional acres of pond area is projected to accommodate the high end of potential secondary waste flow (32 gpm) generated by active treatment alternative with a 25 percent design safety factor. It is assumed that land area immediately to the west of the existing pond and adjacent land area beyond the Site's current fence line boundary could be utilized for pond installation, as necessary. Installation of a pond perimeter influent distribution manifold, allowing for sheet flow down the interior pond berm slope, will increase the evaporative surface area without essentially changing the passive evaporation pond to an equipment-enhanced system or requiring a larger total pond footprint (pond area plus perimeter berm walls). The increase in evaporation efficiency potentially afforded by an influent distribution system should be included as a design input for the sizing of additional passive evaporation ponds.

5.4.2 Alternative 4B—Enhanced Solar Evaporation Ponds (WAIV)

Operation of a WAIV process will require periodic cleaning of the textile sheets to maintain optimal performance. As noted above, storage and pumping will be required to clean the sheets through the same flow path as used for routine operation, essentially a CIP process. The volume of cleaning solution required and frequency of cleaning cycles is dependent on water quality characteristics, flow, and climatic conditions. The WAIV equipment supplier has indicated that a sodium chloride solution applied on a weekly to biweekly basis may provide adequate cleaning. Should a more aggressive cleaner be required, the supplier recommends a 1 percent solution of sulfamic or citric acid. Textile sheets have an expected lifespan of 5 to 7 years, after which they would have to be disposed of as process waste and replaced (Golder 2014e).

Alternative 4B, incorporating the WAIV process, was developed as a primary treatment process for groundwater treatment at flow rates of 40 gpm and 100 gpm. The WAIV process is also viable as a secondary waste management process and could be utilized to minimize the surface area required for additional solar evaporation for the treatment alternatives that are projected to generate a secondary waste flow greater than 20 gpm. A block flow diagram depicting major equipment along with the process flow path for Alternative 4B is shown in Figure 9. Flow paths and equipment associated with process reagent additions and secondary wastes are also shown.

The WAIV process utilizes closely spaced textiles hung vertically over a drip-down collection pan. Water is dripped over the textile sheets and evaporated by sun and wind. WAIV has been primarily used for brine management in locations that are space-limited. The technology is suited for locations that are frequently windy and have high evaporation rates. A typical WAIV module is shown in Figure 10. The WAIV process incorporates modular design such that greater influent flow rates can be handled by adding modules. Spare modules may also be included in a WAIV process design to allow for continuous operation when routine or nonroutine maintenance activities are required.

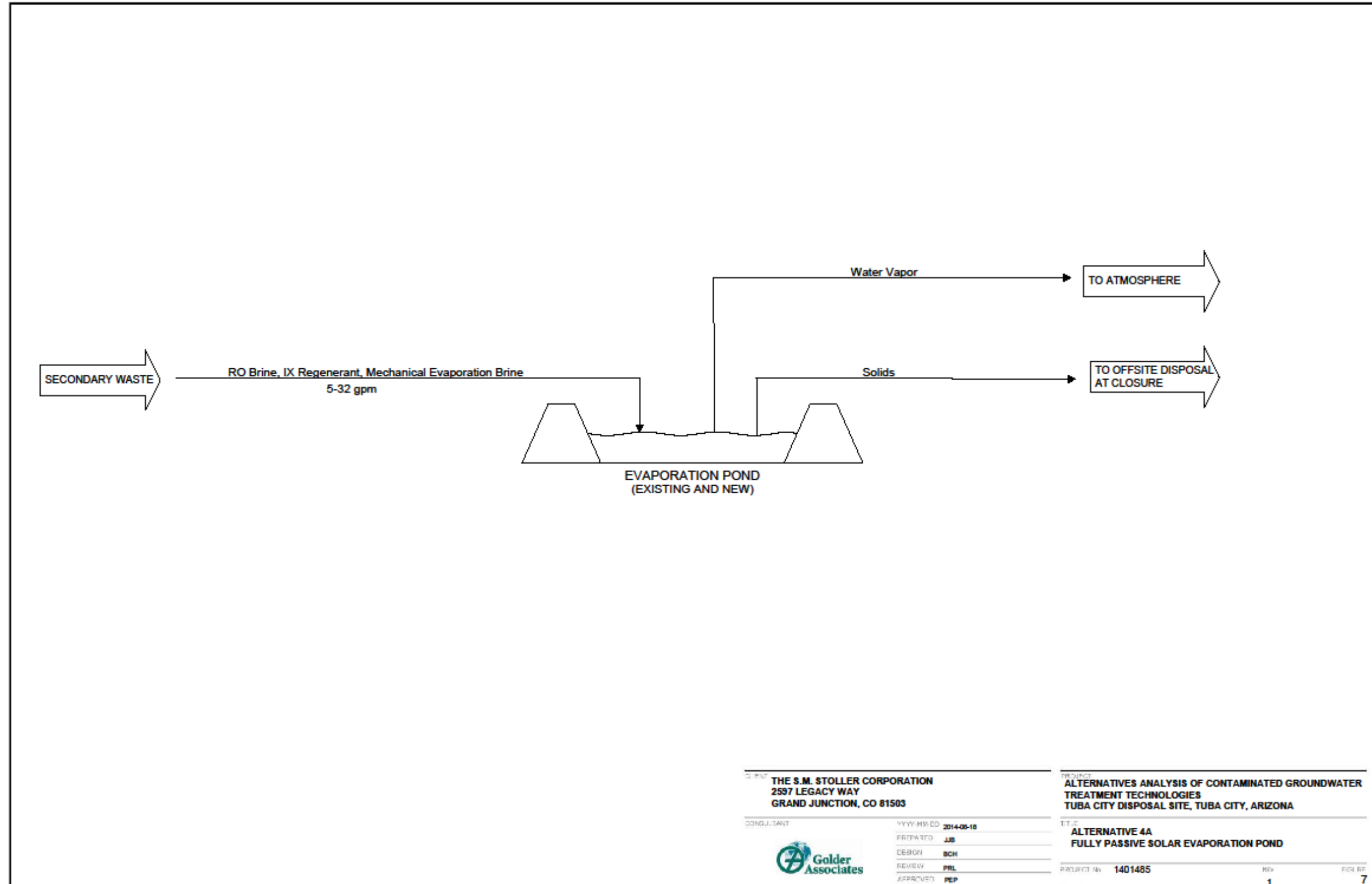

Figure 7. Block Diagram for Alternative 4A



Figure 8. Proposed Location of New 3-Acre Evaporation Pond

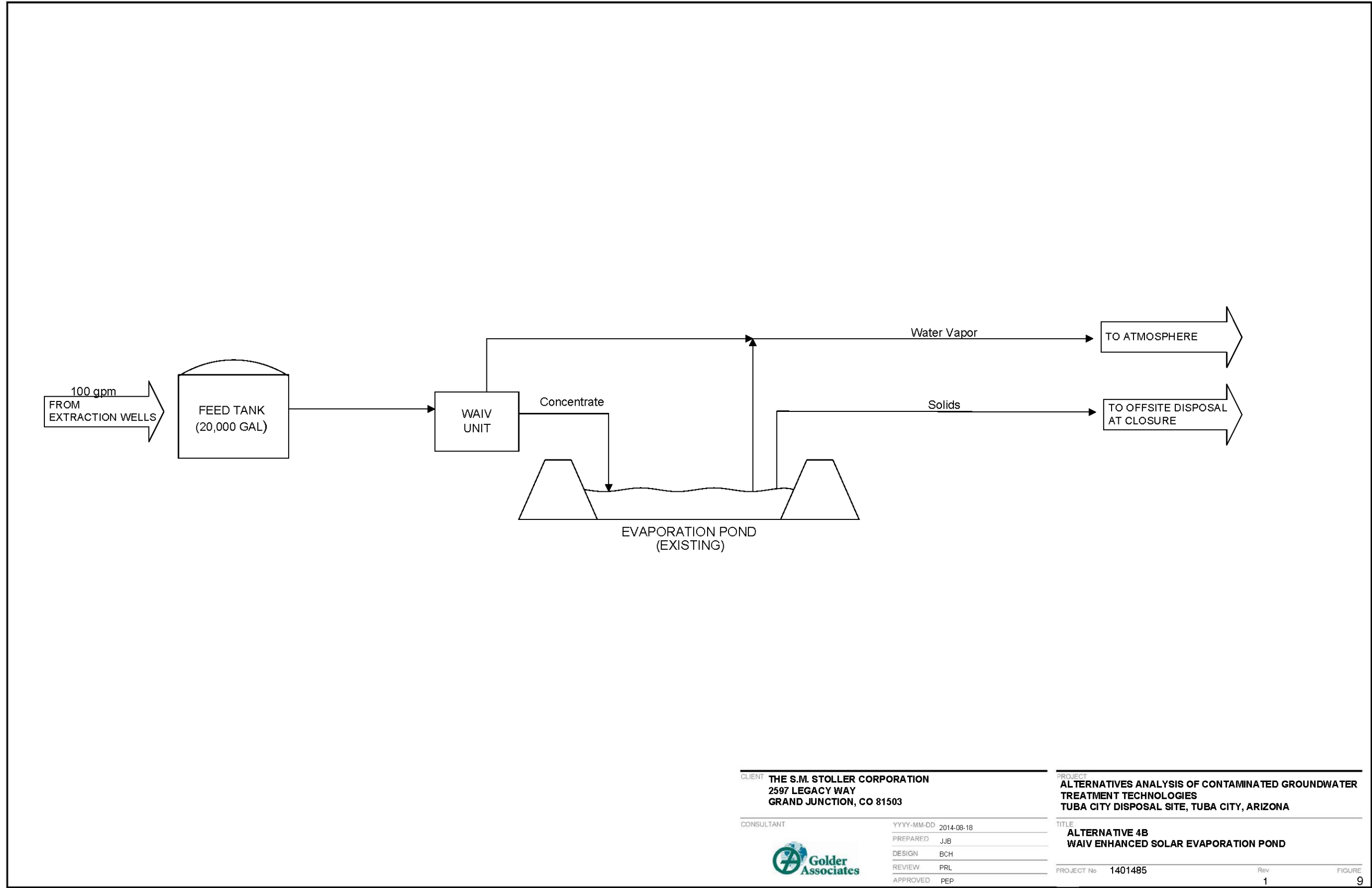

Figure 9. Block Diagram for Alternative 4B

This page intentionally left blank

Excess flow, which does not evaporate while in contact with the textile sheets, is collected at the bottom of the WAIV module and is conveyed to a conventional passive solar evaporation pond. A typical WAIV installation process is shown in Figure 10. WAIV modules may be installed on the perimeter or within a conventional solar evaporation pond. A once-through flow pattern is typical.



Figure 10. Typical WAIV Process Installation

Conceptual design calculations for a WAIV process system were performed by Lesico Cleantech (supplier of WAIV equipment). The Tuba City and Winslow climatic data (NOAA 2014, ADWR 2011) and groundwater IDB water-quality characterization were provided to Lesico Cleantech as basis for their conceptual design. A summary of design parameters is presented in Table 11. The total surface area footprint required for WAIV process equipment and an associated passive solar evaporation pond for a 100 gpm flow rate is 4 acres. The total surface area footprint required for a 40 gpm system is 1.5 acres.

Table 11. Wind-Aided Intensified Evaporation (WAIV) Concept for Groundwater Treatment

Parameter	WAIV Design Parameters	
	100 gpm	40 gpm
Total Volume Treated (gallons/year)	52,560,000	21,024,000
Length of WAIV Module (feet)	66	66
Height of WAIV Module (feet)	13	13
Width of WAIV Module (feet)	26	26
Number of Sheets per Module	100	100
Number of WAIV Modules	48	18
Total Area of WAIV Plant ^a (acres)	4	1.5
Power Requirements (kW)	6.5	2.5

Notes:

^a The total area of the WAIV plants are inclusive of the footprint for WAIV modules and a collection pond.

Table 12 provides an equipment list with brief descriptions of the major equipment items supporting a WAIV installation.

Table 12. Alternative 4B Wind-Aided Intensified Evaporation (WAIV)—Major Equipment List

Item	Name	Description
1	Feed Tank – Existing	20,000 gal vertical tank with automated level control.
2	Feed Pump	40 gpm or 100 gpm capacity at 30 feet of head.
3	Foundation for WAIV modules	Foundation to support WAIV module installation. A foundation slab will also serve to collect water that passes through the WAIV's textile sheets.
4	Conveyance piping to evaporation pond	Water collected at the bottom of WAIV modules is conveyed to a passive solar evaporation pond.
5	Cleaning components	Sodium chloride (NaCl) cleaning solution storage tank, NaCl solution pump, and distribution manifold for cleaning textile sheets in place. If acid is required for cleaning, the equipment supplier recommends sulfamic or citric acid. Similar components (storage, pump, and distribution manifold) will be required.
6	Evaporation Pond – Existing	Collection pond for water that passes through the WAIV modules (see example in Figure 10).

Abbreviations:

gal = gallon

WAIV-enhanced evaporation can serve as a primary water-removal process at either 40 gpm or at 100 gpm. All the contaminants removed by the WAIV process will be concentrated in the existing evaporation pond for later disposal; however, all the water is evaporated which will preclude returning any treated effluent to the aquifer.

As a brine management process, WAIV would reduce the pond surface area required to evaporate secondary wastes from the alternatives, which include RO. The 40 gpm WAIV process could also be paired with the existing solar evaporation pond and would provide excess evaporation capacity for the secondary waste streams from any alternative.

The operation of a WAIV process could be automated by PLC and controlled by HMI. The speed of the feed pump, if equipped with a variable frequency drive, could be automatically adjusted based on atmospheric conditions (higher influent flow rate for dry, windy weather conditions). The collection pond level could also be used as a control signal, allowing operation of the WAIV process when the pond level is low and shutting the WAIV process down if the pond level is high.

Operation of a WAIV process will require periodic cleaning of the textile sheets to maintain optimal performance. As noted in Table 12, cleaning solution storage and pumping will be required to clean the sheets through the same flow path as used for routine operation, essentially a CIP process. The volume of cleaning solution required and frequency of cleaning cycles is dependent on water quality characteristics, flow, and climatic conditions. Cleaning with a sodium chloride solution may be possible, if the potential for formation of carbonate scale is low. Acid cleaning with a 1 percent solution of sulfamic or citric acid will be required if scale formation is an issue. Cleaning may be required on a weekly to biweekly basis and should be verified by pilot testing. The useful lifespan of textile sheets is estimated at 5 to 7 years, after which time they will be disposed of as process waste (Golder 2014e).

5.5 Estimates of Capital and Operating Expenses

CAPEX estimates have been developed to an order-of-magnitude (± 50 percent) level of accuracy. The CAPEX estimates include:

- Individual line item costs for treatment process components—developed as project-specific vendor estimates or referenced to Golder’s internal quotes database for common items (tanks, pumps, mixers);
- Allowance for instrumentation and controls, based on Golder experience;
- Civil site work and building costs, based on unit cost factors (e.g., cost per square foot for building, cost per cubic yard for total volume of concrete foundations);
- Process equipment installation cost as a percentage of capital equipment cost; and
- Construction management, engineering, contingency as factors of total capital cost.

The possibility of leasing rather than purchasing process equipment was discussed with suppliers of RO, EC and mechanical evaporation equipment. Two factors weigh strongly against the leasing option:

- Due to the length of the operational period, suppliers would place a zero residual value on equipment at the end of lease. Leasing would essentially amount to a “time payment” plan, and would include the full cost of equipment plus interest.
- The potential for radioactive residual contamination on equipment could require decontamination before the equipment could be returned to the supplier’s inventory of leasable equipment. The cost of decontamination and potentially the disposal of low-level radioactive waste would also be calculated in to the lease rate.

Should a pilot program of up to 1 year in duration be undertaken to establish design parameters for a full-scale treatment system, pilot equipment leasing may be cost-effective. However, the potential for radioactive residual contamination may result in a higher lease cost than for a

nonradioactive application. Nonroutine equipment cleaning and decontamination would likely be required prior to returning leased equipment to the supplier's inventory.

OPEX estimates have also been developed and include:

- Estimated labor force (supervisor, lead operator; assistant operator; maintenance technician; professional support, including health and safety and engineering);
- Chemical reagent consumption, including pH adjustment, pretreatment chemicals for RO, CIP chemicals for equipment maintenance, EC blades, antiscalant for evaporator, regenerant/backwash chemicals, coagulant/flocculant;
- Utility power requirements;
- Secondary waste disposal during operations and at closure; and
- Capital replacement cost over the life of the project.

OPEX line items with the exception of labor force and capital replacement costs are based primarily on IDB water chemistry and the 100 gpm IDB flow rate. Labor force and capital replacement costs are based primarily on process complexity. Note that some components of OPEX, which are common to all alternatives, such as compliance sampling, analysis, and reporting, are not included in the cost summaries. OPEX estimates are developed to highlight cost differentiators between the alternatives.

An OPEX estimate has been developed for the 40 gpm IDB flow rate only for the WAIV-enhanced evaporation alternative (Alternative 4B).

Ten-year life-cycle costs are developed to account for initial capital investment and annual OPEX in out-years, utilizing a net present value (NPV) calculation method. CAPEX and OPEX estimates and the calculated 10-year life-cycle costs are presented in the following sections.

5.5.1 CAPEX Estimates

CAPEX estimates for Alternatives 1A, 1B, 2A, 2B, 3, 4A, and 4B are summarized in Table 13. The estimated CAPEX for Alternative 4A (passive solar evaporation) is for a twin pond to serve as a secondary waste management unit. A proportionate adder for passive evaporation expansions accounting for secondary wastes generated in excess of 10 gpm is included as a facility cost for Alternatives 1A, 1B, and 2A.

Table 13. Summary of Capital Expense Estimates for Groundwater Treatment Alternatives

Name	Flow Rate (gpm)	Process Equipment ^a	Facility/ Installation ^b	Indirect Costs ^c	Total Estimated CAPEX
1A – RO with Manganese pretreatment	100	761,000	3,250,000	2,820,000	\$6,831,000
1B – RO with IX pretreatment	100	875,000	2,250,000	2,200,000	\$5,325,000
2A – EC with RO Polish	100	2,720,000	2,850,000	3,920,000	\$9,490,000
2B – Standalone EC	100	2,190,000	740,000	2,060,000	\$4,990,000
3 – Mechanical Evaporation	100	4,320,000	962,000	3,410,000	\$8,692,000
4A – Passive Solar Evaporation ^d	10	0	894,000	629,000	\$1,523,000
4B – Enhanced Solar Evaporation	100 ^e	2,400,000	878,000	2,110,000	\$5,388,000
	40 ^e	900,000	338,000	798,000	\$2,036,000

Notes:

- ^a Process-equipment cost estimate includes all items shown on the major equipment lists and allowances for miscellaneous appurtenances.
- ^b Facility and installation cost estimate includes buildings to house process equipment, new solar evaporation pond for processes generating greater than 10 gpm of secondary waste, process equipment installation, site work, and foundations for large tanks and equipment.
- ^c Indirect costs include estimates for contingency, general contractor overhead, engineering design, and construction oversight as percentages of the total direct cost (direct equipment plus facilities and installation). Percentages used are 30 percent for contingency, 15 percent for general contractor overhead, 8 percent for engineering design, and 6 percent for construction management.
- ^d Alternative 4A Passive Solar Evaporation CAPEX estimate is for construction of a twin pond, immediately west of the existing pond. The estimated cost for this pond is incorporated into the estimates for alternatives that are projected to produce a volume of secondary waste greater than 10 gpm (baseline for existing treatment system).
- ^e Facility and installation cost for the 40 gpm and 100 gpm WAIV systems includes placement of WAIV modules and utilizes the existing solar evaporation pond as the WAIV collection pond.

5.5.2 OPEX Estimates

OPEX estimates for Alternatives 1A, 1B, 2A, 2B, 3, 4A, and 4B are summarized in Table 14. The estimated OPEX for Alternative 4A (passive solar evaporation) is for operation of the existing pond and a new twin (3-acre) pond serving as an additional secondary waste management unit. Alternatives which generate secondary wastes in excess of 20 gpm (1A [31 gpm], 1B [24 gpm], 2A [32 gpm]) will require proportionately larger additions of passive solar evaporation ponds. Components of OPEX which will increase in proportion to flow rate include utility power and routine maintenance, while labor and waste disposal costs are expected to be relatively constant across the range of secondary waste flows.

Table 14. Summary of Operating Expense Estimates for Groundwater Treatment Alternatives

Alternative	Name	Labor ^a	Utility Power ^b	Chemicals, Membranes, Filter Media	Routine Maintenance ^c	Waste Disposal ^d	Total Estimated Annual OPEX
1A	RO with Manganese Pretreatment	312,000	48,000	138,000	42,000	90,000	\$630,000
1B	RO with IX Pretreatment	312,000	52,000	55,000	79,000	87,000	\$585,000
2A	EC with RO Polish	471,000	198,000	56,000	150,000	90,000	\$965,000
2B	Standalone EC	318,000	165,000	28,000	121,000	43,000	\$675,000
3	IX Pretreatment and Mechanical Evaporation	225,000	206,000	41,000	151,000	92,000	\$715,000
4A	Passive Solar Evaporation ^e	59,000	4,000	0	31,000	90,000	\$184,000
4B	Enhanced Solar Evaporation	63,000	11,000	30,000	44,000	95,000	\$233,000

Notes:

^a Labor is estimated on the basis of full-time equivalents for operation of the treatment alternatives. Labor includes all operator's time onsite, including other duties (monitoring wells, extraction wells, evaporation pond monitoring, general administrative tasks). Labor does not include salaries of the site manager and site engineer, as they are assumed to be equal for all alternatives.

^b Utility power is based on an estimate of total connected load for all process equipment that requires electrical power. Onsite power generation is not considered. All alternatives will be capable of utilizing power from the Site's PV array.

^c Routine maintenance includes labor and materials for performance of maintenance functions (monitoring equipment performance, calibration, replacement of wear parts) and includes a factor for capital replacement for equipment that does not have a 10-year design life.

^d The unit cost for disposal of evaporation pond sludge at closure is estimated at \$90 per cubic yard. This unit cost includes hauling and disposal and is assumed to be double the cost of conventional solid waste disposal.

^e Alternative 4A Passive Solar Evaporation OPEX estimate is for use of the existing pond and a new 3-acre pond. Installation of additional passive solar evaporation in proportion to secondary waste flows projected for Alternatives 1A, 1B, and 2A would be required. The OPEX cost for Alternative 4A is at the low end of a range of secondary waste management for all Alternatives. It is presented as indicative of the additional cost resulting from increased flows of secondary waste streams, within the current order-of-magnitude level of cost estimate detail.

5.5.3 Life-Cycle Costs

Life-cycle costs have been developed for all alternatives. CAPEX and 10 years of annual OPEX estimated costs were used to calculate the NPV for each alternative over the planned 10-year project life. Table 15 provides a summary of calculated NPVs.

Table 15. Summary of 10-Year Life-Cycle Cost Analysis for Groundwater Treatment Alternatives

Alternative	Description	NPV ^a
1A	RO with Manganese Pretreatment	\$12,500,000
1B	RO with IX Softening Pretreatment	\$10,580,000
2A	EC with RO Polish	\$18,180,000
2B	Standalone EC	\$11,080,000
3	IX Softening Pretreatment with MVR Evaporation	\$15,150,000
4A	Passive Solar Evaporation	\$ 3,180,000
4B	Enhanced Solar Evaporation (WAIV) 100 gpm	\$ 7,580,000
4B	Enhanced Solar Evaporation (WAIV) 40 gpm	\$ 3,760,000

Notes:

^a An inflation factor of 3 percent and a discount factor of 5 percent were used in calculation of NPVs.

5.6 Alternatives Analysis

Alternatives have been qualitatively scored against criteria described in the SOW (DOE 2014). Criteria are weighted, yielding a higher cumulative score for alternatives that are ranked higher in the more important (heavily weighted) criteria. Criteria definitions and scoring guidance are presented in Table 16 and Table 17.

Table 16. Analysis Criteria Definitions and Assigned Weights

Criteria	Scoring Weight	Definition
Implementability	5%	Process-equipment availability as a pre-engineered, packaged system, compatible with industry standard controls system, operable on standard utility power and Site's PV array.
Technical Effectiveness	15%	Capability to provide highly efficient recovery of treated water (current system can provide 85 percent), consistently producing a treated effluent that meets federal regulatory limits from "Health and Environmental Protection Standards for Uranium and Thorium Mill Tailings" (40 CFR 192), and nonregulatory site-specific effluent treatment objectives.
Maintainability	10%	Ease of inspectability, readily accessible maintenance points, process monitoring and troubleshooting, availability of required spares, technician's skill level required for maintenance and repairs, preventive maintenance requirements, downtime for routine and nonroutine maintenance.
Reliability	15%	The expected performance of process equipment, accounting for unplanned downtime. High system reliability may result from mechanical simplicity (few moving parts), process equipment redundancy, process control automation, and in-process storage capacity (allowing for upstream components to remain in operation while a downstream component is offline for repair or maintenance).
Operability	10%	Process complexity; operational and maintenance labor requirements (time and skill levels); process equipment compatibility with industry-standard PLC supervisory control and data acquisition (SCADA); using onsite or remote HMI, capability for continuous operations (24/7) attended or unattended.
Cost	20%	CAPEX, OPEX, 10-year design life NPV.
Flexibility	5%	Flow and influent water quality, campaign versus continuous operations, ability to meet present and future treatment requirements.
Safety	10%	Personnel safety hazards, such as low clearances, trip hazards, noise, pinch points, elevated platforms, space-constrained walkways/work areas. Process hazards, such as extreme (high or low) process temperatures or pressures, risk of exposure to electrical or mechanical energy, chemical hazards (corrosivity, volatility, fumes).
Environment	5%	Hazards related to chemical reagent shipments, onsite storage and use, secondary waste characteristics and volume.
Schedule	5%	Includes duration for lead time, complexity of installation, and pilot testing as needed.

Table 17. Criteria Matrix Scoring Guidance

Criteria	Scoring	Guidance
Implementability	100	Equipment is skid mounted, compact, instrumentation and controls compatible with industry standard PLC/HMI, off-the shelf, no unusual power or site requirements.
	80	One item missing or impacted from "100" score.
	0 to 60	Ranked relative to top two scorers and the standards for "100" score.
Technical Effectiveness	100	>90 percent water recovery, meets all regulatory (40 CFR 192) and all stakeholder goals.
	75	>50 to 90 percent water recovery, meets all regulatory and all stakeholder goals.
	50	>50 to 90 percent water recovery, meets all regulatory goals only.
	25	0 to 50 percent water recovery, meets all regulatory and all stakeholder goals.
	0	0 to 100 percent water recovery, does not meet regulatory or stakeholder goals.
Maintainability	100	No unusual components, ready availability of spares, standard level of mechanical maintenance, minimal downtime for maintenance and cleaning cycles, easily accessible maintenance points.
	0 to 80	Ranked relative to top scorer and the standards for "100" score.
Reliability	100	>99 percent online (<1 percent downtime for routine and unscheduled maintenance).
	80	>95 percent online.
	0 to 60	Relative ranking in comparison to standards for higher scores.
Operability	100	No more than two full-time equivalents when operators are in attendance, capability for unattended overnight and weekend operation, PLC automation with onsite and remote HMI control screens, conventional ancillary equipment.
	0 to 80	Ranked relative to top scorer and the standards for "100" score.
Cost	100	Lowest NPV for 10-year project life.
	1 to 99	Scored interpolated between highest and lowest NPV.
	0	Highest NPV.
Flexibility	100	Can be turned up/down from set points of 40 gpm and 100 gpm with minimal operator effort, no downtime, single train of equipment.
	80	Can be turned up/down from set points of 40 gpm and 100 gpm with minimal operator effort, no downtime, parallel equipment trains required.
	0 to 60	Flow rate change from 40 to 100 gpm (or 100 to 40 gpm) requires more extensive operator effort and longer shutdown/restart, or other higher level of complexity.
Safety	100	Minimized risk of personnel injury—noise, pinch points, low clearances, elevated platforms, space-constrained work areas/walkways. Minimized process-related hazards—chemical hazards (corrosivity, fumes, volatility), extreme process temperature or pressure, confined space entry, electrical and mechanical hazards.
	0 to 80	Ranked relative to top scorer and the standards for "100" score.
Environment	100	Lower generation of secondary waste than current system, lowest volume/hazards associated with process chemical reagents, does not introduce new wastes (incompatible with long-term accumulation in evaporation pond and disposal as low-level waste at closure).
	60 to 80	Secondary waste generation comparable to current system, low volume/hazards associated with process chemical reagents, does not introduce new wastes.
	0 to 40	Greater generation of secondary waste than current system, greater chemical volumes/hazards, introduces new waste stream requiring different disposition.
Schedule	100	Shortest time to implement.
	0 to 80	Ranked relative to shortest time (additional time for design, testing, fabrication, shipping, supplier backlog, site installation, commissioning, and startup).

5.6.1 Matrix Criteria Alternative Analysis Results

Summary discussions of scoring rationale are provided in the following subsections.

5.6.1.1 Alternative 1A—RO with Manganese Pretreatment

Alternative 1A is an RO treatment process with pretreatment for manganese removal only. While other RO-fouling constituents such as silica, calcium, and magnesium can be dealt with through addition of antiscalant, manganese at its IDB concentration will significantly inhibit RO treatment efficiency, and it must be removed from the influent stream. Manganese can be effectively removed through use of a multimedia filter. Following the multimedia filter, two RO units operated in series (with the second RO unit receiving treated effluent from the first RO unit) are required to produce a treated effluent in compliance with all treatment objectives. Summary scoring for Alternative 1A is presented in Table 18.

Table 18. Matrix Criteria Summary Analysis for Alternative 1A

Criteria	Score	Rationale/Comments
Implementability	80	Conventional equipment, compatible with standard PLC/HMI control, can be operated using the Site's solar PV power. Influent preheated through use of the Site's solar concentrators will also be beneficial to RO treatment efficiency. Coordination of multiple supplier packages will be required.
Technical Effectiveness	75	Treated effluent recovery efficiency is projected at 69 percent, meeting all treatment objectives. As membranes age and go through cleaning cycles, contaminant rejection efficiency will be reduced, and exceedance of the nitrate objective could occur, leading to membrane replacement.
Maintainability	80	ROs will be equipped with automated CIP skids. Multimedia (greensand) filter will be automatically backwashed as needed. This alternative is readily maintainable but includes multiple unit operations.
Reliability	60	Multiple unit operations, multiple pumps, and chemical feeds may lead to unscheduled downtime due to component failures. Shelf-ready spares or installed redundancy may be needed to improve system reliability.
Operability	80	Conventional process, minimal need for operator expertise. Equipment will be installed inside a new building or provided in enclosures (sea-land containers) to avert weather-related impacts to process efficiency.
Estimated Cost	60	Within the margin of accuracy for current cost estimation, this alternative is cost-competitive.
Flexibility	60	Turn-up/turndown for RO is limited to ± 25 percent. Parallel trains may be required to allow for operation at either 40 gpm or 100 gpm. Membranes must be cleaned and properly stored if taken out of service for more than 2–3 days. RO can better handle changes in influent contaminant concentrations than changes in flow rate.
Safety	50	Requires use of chemical oxidant in greensand filter, high pressure pumps for RO units.
Environment	70	Oxidant chemical, antiscalant, CIP, and pH adjustment chemicals are required. Secondary waste generation will be greater than the current evaporation system.
Schedule	100	Multiple suppliers for all components, conventional equipment, no need for unusual materials of construction. Off-the-shelf units should be available.

5.6.1.2 Alternative 1B—RO with IX Softening Pretreatment

Alternative 1B is an RO treatment process with pretreatment for removal of hardness constituents, calcium, and magnesium through an IX softening process similar to the system currently in use at the Site. Manganese removal, sufficient for RO operability, will also be

achieved in the IX pretreatment step. While antiscalant can be used to mitigate membrane fouling effects of calcium and magnesium, RO operational efficiency will be improved by removal of these constituents. Similar to Alternative 1A, two RO units operated in series (with the second RO unit receiving treated effluent from the first RO unit) are required to produce a treated effluent in compliance with all treatment objectives. Summary scoring for Alternative 1B is presented in Table 19.

Table 19. Matrix Criteria Summary Analysis for Alternative 1B

Criteria	Score	Rationale/Comments
Implementability	80	Conventional equipment, compatible with standard PLC/HMI control, can be operated using the Site's solar PV power. Influent preheated through use of the Site's solar concentrators will also be beneficial to RO treatment efficiency.
Technical Effectiveness	75	Treated effluent recovery efficiency is projected at 76 percent, meeting all treatment objectives. Cleaning and replacement should be less frequent in comparison to Alternative 1A due to IX softening pretreatment.
Maintainability	80	ROs will be equipped with automated CIP skids. IX columns will be automatically regenerated as needed. New IX equipment would be installed, but this is a familiar process to Site operators. This alternative is readily maintainable but includes multiple unit operations.
Reliability	60	Multiple unit operations, multiple pumps, and chemical feeds may lead to unscheduled downtime due to component failures. Shelf-ready spares or installed redundancy may be needed to improve system reliability.
Operability	80	Conventional process, minimal need for operator expertise. New IX equipment will be installed inside the existing IX building, and ROs will be installed in a new building to avert weather-related impacts to process efficiency.
Estimated Cost	80	Within the margin of accuracy for current cost estimation, this alternative is cost-competitive and lower in life-cycle cost than Alternative 1A.
Flexibility	60	Turn-up/turndown for RO is limited to ± 25 percent. Parallel trains may be required to allow for operation at either 40 gpm or 100 gpm. Membranes must be cleaned and properly stored if taken out of service for more than 2–3 days. RO can better handle changes in influent contaminant concentrations than changes in flow rate.
Safety	70	High-pressure pumps for RO units.
Environment	60	IX regenerant, antiscalant, CIP, and pH adjustment chemicals are required. Secondary waste generation will be greater than the current evaporation system.
Schedule	100	Multiple suppliers for all components, conventional equipment, no need for unusual materials of construction, off-the-shelf units should be available.

5.6.1.3 Alternative 2A—EC with Polishing RO

Alternative 2A utilizes EC as the main treatment process and RO for effluent polishing to meet nitrate, sulfate, and TDS treatment objectives. EC requires no pretreatment or chemical process reagents. Iron blades in the reaction chamber are consumed and contribute to the volume of secondary waste as iron-oxide solids are formed. Clarification of EC effluent through gravity or vacuum-aided settling is required, and an additional membrane filtration step (ultrafiltration) is included to optimize the efficiency of the polishing RO. Similar to the RO-based alternatives, two RO units operated in series (with the second RO unit receiving treated effluent from the first RO unit) are required to produce a treated effluent in compliance with all treatment objectives. Summary scoring for Alternative 2A is presented in Table 20.

Table 20. Matrix Criteria Summary Analysis for Alternative 2A

Criteria	Score	Rationale/Comments
Implementability	80	Conventional equipment, compatible with standard PLC/HMI control, can be operated using the Site's solar PV power.
Technical Effectiveness	75	Treated effluent recovery efficiency is projected at 68 percent, meeting all treatment objectives. Membrane cleaning and replacement should be less frequent in comparison to Alternative 1A due to EC removing the majority of the contaminant metals load.
Maintainability	40	EC maintenance will involve routine replacement of reaction chamber blades. UF will require periodic backwash to remove accumulated solids. ROs will be equipped with automated CIP skids.
Reliability	20	More complex process than any other alternative, leading to higher probability of unscheduled downtime due to component failures. Shelf-ready spares or installed redundancy may be needed to improve system reliability.
Operability	60	Less-conventional process than RO or evaporation, may require a higher level of operator expertise to handle EC, clarification, ultrafiltration, and RO processes. New EC unit and ROs will be installed in a new building to avert weather-related impacts to process efficiency.
Estimated Cost	0	Highest 10-year life-cycle cost.
Flexibility	40	EC/clarification may not respond well to changes in flow rate or water chemistry, requiring an extended retention time or increased current in the reaction chamber. Turn-up/turndown for RO is limited to ± 25 percent. Parallel trains may be required to allow for operation at either 40 gpm or 100 gpm. Membranes must be cleaned and properly stored if taken out of service for more than 2–3 days. RO can better handle changes in influent contaminant concentrations than changes in flow rate.
Safety	50	Risk of exposure to electrical hazard, high-pressure pumps for RO units.
Environment	40	RO antiscalant, CIP, and pH adjustment chemicals are required. Secondary waste generation will be greater than the current evaporation system.
Schedule	50	Fewer suppliers for EC equipment than for RO, vacuum clarifier is a specialty unit (not an industry standard), no need for unusual materials of construction.

5.6.1.4 Alternative 2B—EC as a Standalone Process

Alternative 2B utilizes EC as a standalone main treatment process, capable of returning a greater volume of treated effluent, but at a quality that will not meet treatment objectives for TDS, sulfate, and nitrate. EC requires no pretreatment or chemical process reagents. Iron blades in the reaction chamber are consumed and contribute to the volume of secondary waste as iron-oxide solids are formed. Clarification of EC effluent through gravity or vacuum-aided settling is required, and an additional membrane filtration step (ultrafiltration) is included. Summary scoring for Alternative 2B is presented in Table 21.

Table 21. Matrix Criteria Summary Analysis for Alternative 2B

Criteria	Score	Rationale/Comments
Implementability	80	Conventional equipment, compatible with standard PLC/HMI control, can be operated using the Site's solar PV power.
Technical Effectiveness	0	Treated effluent recovery efficiency is projected at 95 percent. EC effluent will meet treatment objectives for metals, but not for the stakeholder goals for TDS and sulfate or the 40 CFR 192 regulatory limit for nitrate.
Maintainability	60	EC maintenance will involve routine replacement of reaction chamber blades. UF will require periodic backwash to remove accumulated solids.
Reliability	40	Shelf-ready spares or installed redundancy may be needed to improve system reliability.
Operability	80	Less conventional process than RO or evaporation, may require a higher level of operator expertise to handle EC, clarification, and ultrafiltration. New EC unit will be installed in a new building to avert weather-related impacts to process efficiency.
Estimated Cost	75	Within the margin of accuracy for current cost estimation, this alternative is cost-competitive, and lower in life-cycle cost than RO-based alternatives.
Flexibility	60	EC/clarification may not respond well to unplanned changes in flow rate or water chemistry, requiring an extended retention time or increased current in the reaction chamber.
Safety	60	Risk of exposure to electrical hazard.
Environment	100	The only additive is iron blades, which are consumed by the EC process and leave the system with the secondary waste solids. This alternative presents the lowest projected secondary waste generation.
Schedule	50	Fewer suppliers for EC equipment than for RO, vacuum clarifier is a specialty unit (not an industry standard), no need for unusual materials of construction.

5.6.1.5 Alternative 3—Mechanical Evaporation

Alternative 3 involves replacement of the existing mechanical evaporator with a new MVR evaporator. A new IX softening pretreatment unit will also be installed. The new evaporator will return treated effluent with water quality comparable to that of the existing unit. A greater quantity of treated effluent is projected, as the new MVR evaporator will have a greater online factor. In the past 3 years, the online factor for the existing treatment system has been 35 percent or less, while a new system is expected to have an online factor of 80 to 90 percent based on the greater reliability of the system. Summary scoring for Alternative 3 is presented in Table 22.

Table 22. Matrix Criteria Summary Analysis for Alternative 3

Criteria	Score	Rationale/Comments
Implementability	100	Pre-engineered systems are available. Minimal connections required to tie in to process stream. Controllable through standard PLC/HMI.
Technical Effectiveness	100	Treated effluent recovery efficiency is projected at 90 percent, meeting all treatment objectives.
Maintainability	80	IX softening pretreatment and evaporator cleaning can be done with automated CIP systems.
Reliability	80	Improvements have been made in MVR evaporation technology, and the new system can be expected to be more reliable than the existing system.
Operability	80	Operations can be automated to a point requiring minimal operator interface.
Estimated Cost	30	High CAPEX, moderate OPEX, and 10-year life-cycle cost.
Flexibility	80	Mechanical evaporation is flexible with regard to influent water chemistry. While best operated in a continuous mode, evaporators can be shut down and restarted with relative ease.
Safety	70	Work on elevated platform may be required. Process pressure and temperature are greater than for other alternatives. Cleaning chemicals are required.
Environment	60	Waste streams and process reagents are very similar to those of the existing system.
Schedule	60	Fabrication and shipping to the Site will be lags in the implementation schedule.

5.6.1.6 *Alternative 4A—Passive Solar Evaporation Ponds for Secondary Waste Management*

Conceptual design for passive solar evaporation as an alternative for treatment of IDB flow rates of 40 gpm and 100 gpm flow revealed pond area requirements of approximately 15 acres and 40 acres, respectively. The relative large footprints and estimated CAPEX made passive solar evaporation infeasible as a primary treatment process alternative at either IDB flow rate.

Alternative 4A involves installation of a second 3-acre (twin) passive solar evaporation pond, immediately to the west of the existing pond to increase onsite capacity for secondary waste management. Summary scoring for Alternative 4A is presented in Table 23, however Alternative 4A is not a full flow treatment alternative to be compared on an equal basis with the other alternatives.

It is important to note that secondary waste streams projected for Alternatives 1A, 1B, and 2A at 31 gpm, 24 gpm, and 32 gpm respectively, will require additional passive solar evaporation beyond the installation of a twin pond. The secondary waste components of CAPEX and OPEX estimates for these alternatives are based on their projected secondary waste flows. The conceptual design, cost estimation, and matrix scoring of the Alternative 4A twin pond is presented as indicative of the viability for onsite expansion of secondary waste handling capacity.

Table 23. Matrix Criteria Summary Analysis for Alternative 4A

Criteria	Score	Rationale/Comments
Implementability	0	A score of 0 for implementability has been assigned for treatment of the IDB flow rates via passive solar evaporation ponds. Estimated surface areas for passive solar ponds sized for 40 and 100 gpm flows are infeasibly large (and costly) at 15 acres and 40 acres, respectively. Installation of a passive solar evaporation pond to increase the Site's capacity for handling secondary wastes is readily implementable. A 3-acre area immediately to the west of the existing pond is available, and would double the solar evaporation capacity to approximately 20 gpm. Additional acreage will be needed for secondary waste flows up to 32 gpm.
Technical Effectiveness	25	Passive evaporation will meet all regulatory and stakeholder water treatment objectives but will return no treated effluent for aquifer restoration.
Maintainability	100	Maintenance is limited to monitoring influent flow and containment sump.
Reliability	100	Passive solar evaporation has proven reliability over 10+ years of operation on the Site.
Operability	100	Very minimal operator involvement is needed.
Estimated Cost	100	Estimated CAPEX and OPEX are the lowest of all alternatives. However, Alternative 4A pond does not have capacity to treat the full extraction flow.
Flexibility	60	Passive evaporation is flexible with regard to water chemistry but inflexible to flow rate beyond its designed maximum. Weather conditions also affect the pond evaporation rate. Pond level must be managed to account for high and low evaporation seasons as well as storm events.
Safety	80	Minimal process-safety hazards. Personnel safety hazards include slipping into the pond. Personnel hazards can be physically and administratively mitigated.
Environment	80	Pond evaporation is representative of the baseline condition for generation of secondary waste. No new wastes or increased volume of wastes would be generated. No chemicals are required for pond operation.
Schedule	80	Pond design and installation are not expected to present schedule issues. No commissioning or startup challenges are anticipated.

5.6.1.7 Alternative 4B—Enhanced Solar Evaporation

Alternative 4B involves installation of a WAIV plant. WAIV treatment has been sized for full flow (100 gpm) and for use as a secondary waste management process (up to 40 gpm). Influent flow to the WAIV plant will be pumped to the top of each module (48 modules for 100 gpm capacity, 18 modules for 40 gpm capacity). Water that does not evaporate while in contact with the hanging textile sheets is collected and conveyed to the existing evaporation pond. Summary scoring for Alternative 4B is presented in Table 24.

Table 24. Matrix Criteria Summary Analysis for Alternative 4B

Criteria	Score	Rationale/Comments
Implementability	80	Installation of 50 modules for full flow may present implementability issues. Textile sheets are of proprietary materials and design, with a single source of manufacture in Israel.
Technical Effectiveness	25	WAIV evaporation will meet all regulatory and stakeholder water treatment objectives, but will return no treated effluent for aquifer restoration.
Maintainability	80	Maintenance is similar to passive evaporation, but also includes periodic cleaning and eventual replacement of the textile sheets.
Reliability	100	WAIV evaporation is a relatively new technology, but is expected to be reliable, as the Site climate (windy and dry) is very conducive to enhanced passive treatment.
Operability	80	Very minimal operator involvement is needed.
Estimated Cost	100	Estimated CAPEX and OPEX are the lowest of all alternatives for treatment of full flow.
Flexibility	60	Enhanced passive evaporation is flexible with regard to water chemistry, but inflexible to flow rate beyond its designed maximum. Weather conditions also affect the evaporation rate. Flexibility could be increased by installation of excess capacity.
Safety	80	Process safety hazard associated with use of acid (if needed) to clean the textile sheets. Personnel hazards can be physically and administratively mitigated.
Environment	80	Textile sheets will require disposal and replacement. Acid may be required for cleaning of textile sheets if sodium chloride rinse solution is not adequate. A 1% citric or sulfamic acid solution would be used.
Schedule	80	Design is modular and should not present a schedule issue. All components except the textile sheets can be fabricated by a licensed technology partner in the United States. Textile sheets are only available from the manufacturer in Israel. Shipping may present schedule lag.

5.6.2 Alternatives Analysis Weighted Scoring

Criteria weighting factors were applied to the raw scores for each alternative, as described above. The overall scoring is presented in Table 25. Alternative 4B enhanced solar evaporation ranked the highest (weighed score 78), followed by Alternative 1B RO with IX pretreatment (weighted score 75), Alternative 3 MVR (weighted score 71) and Alternative 1A RO with manganese pretreatment (weighted score 69). EC Alternatives 2B and 2A ranked the lowest with weighted scores of 56 and 40, respectively.

Table 25. Ranking of Alternatives, Based on Cumulative Weighted Score

Alternative	Name	Weighted Score
4B	Enhanced Solar Evaporation Ponds (WAIV)	78
1B	Ion Exchange Softening Pretreatment and RO	75
3	Mechanical Vapor Recompression Evaporator	71
1A	Manganese Pretreatment and RO	69
2B	Standalone EC	56
2A	EC with RO Polishing	40

Notes:

Alternative 4A (Passive Solar Evaporation Ponds) was found to be infeasible to treat the IDB flow rate, primarily due to the pond surface area requirements, and is therefore not ranked with the alternatives that are capable of treating the IDB flow rate.

A matrix of the evaluation criteria, ranking, and the cumulative weighted score for each alternative is summarized in Table 26.

Table 26. Groundwater Treatment Alternatives Evaluation Matrix

Alternative #	Alternative Name	Pretreatment	Main Treatment	Polish Treatment	Secondary Waste Disposition	Water Recovery (%)	10-Yr NPV (\$)	Evaluation Criteria and Weightings											Comments
								Implementability	Technical Effectiveness	Maintainability	Reliability	Operability	Cost	Flexibility	Safety	Environment	Schedule	Weighted Score	
								5%	15%	10%	15%	10%	20%	5%	10%	5%	5%	100%	
								Rankings (100-highest score)											
1A	RO with Manganese Pretreatment	Manganese removal, antiscalant	Reverse osmosis	pH neutralization	Solar pond evaporation of RO brine, pond dredging with offsite disposal of solids at closure.	69	12,500,000	80	75	80	60	80	60	60	50	70	100	69	Treated effluent is projected to be fully compliant with regulatory and nonregulatory discharge goals. Secondary waste flow is projected at 31 gpm, and would require an additional 6 acres of solar evaporation pond area.
1B	RO with IX Softening Pretreatment	Softening, antiscalant	Reverse osmosis	pH neutralization	Solar pond evaporation of RO brine, pond dredging with offsite disposal of solids at closure.	76	10,580,000	80	75	80	60	80	80	60	70	60	100	75	Treated effluent is projected to be fully compliant with regulatory and nonregulatory goals. Secondary waste flow is projected at 24 gpm, and would require an additional 4.5 acres of solar evaporation pond area.
2A	EC with RO Polishing	None	Electrocoagulation	Reverse osmosis, pH adjust	Drying bed for EC sludge, solar pond evaporation of RO brine, bed and pond dredging with offsite disposal of solids at closure.	68	18,180,000	80	75	40	20	60	0	40	50	40	50	40	Treated effluent is projected to be fully compliant with regulatory and nonregulatory goals. Secondary waste flow is projected at 32 gpm, and would require an additional 6 acres of solar evaporation pond area.
2B	EC as a Standalone	None	Electrocoagulation	pH neutralization	Drying bed for EC sludge, dredging and offsite disposal of solids at closure.	95	11,080,000	80	0	60	40	80	75	60	60	100	50	56	Treated effluent is projected to meet all 40 CFR 192 treatment goals with the exception of nitrate. Does not meet nonregulatory treatment goals of TDS and sulfate.
3	Mechanical Evaporation	Softening, Antiscalant	Mechanical vapor recompression evaporator/condenser	pH neutralization	Solar pond evaporation of mechanical evaporator concentrate waste stream, dredging with offsite disposal of solids at closure.	90	15,150,000	100	100	80	80	80	30	80	70	60	60	71	Treated effluent is projected to be fully compliant with regulatory and nonregulatory goals.
4A	Passive Solar Evaporation	None	None	None	Solar pond evaporation of secondary waste brine streams generated by other alternative treatment processes. Dredging with offsite disposal of solids at closure.	0	3,540,000	0	25	100	100	100	100	60	80	80	80	78	Space and cost constraints preclude passive evaporation as an alternative for treatment of the full flow. Passive evaporation is considered only for disposal of secondary wastes generated by active treatment alternatives. No water will be recovered. Installation of a second pond will be required to provide capability to treat brine waste in excess of 10 gpm.
4B	Enhanced Solar Evaporation	None	Wind-aided intensified evaporation	None	Disposal of textile sheets and pond dredging with offsite disposal of solids at closure.	0	7,580,000	80	25	80	100	80	100	60	80	80	80	78	No water will be recovered, but all treatment objectives will be met.

Abbreviations:
 EC = electrocoagulation;
 RO = reverse osmosis

This page intentionally left blank

6.0 Conclusions

Enhanced solar evaporation utilizing the WAIV process is the highest-rated alternative based on weighted scoring. It is important to note that scoring is subjective and the difference in scores between the top three alternatives is only 10 percent. Enhanced solar evaporation will effectively treat all contaminants and has the lowest estimated NPV; however, it does not allow for return of treated effluent to the aquifer. It is viable at either IDB flow rate (40 gpm or 100 gpm), and is also viable as a secondary waste management process. Conceptual design indicates that operation of a WAIV process at IDB flow rates of 40 gpm and 100 gpm could utilize the Site's existing 3-acre solar evaporation pond with no need for expansion.

It was anticipated that alternatives would present a wider range of recovery efficiencies, based on development of relatively simple (lower-cost) treatment trains and development of more complex (higher-cost) treatment trains. For the alternatives that produced a treated effluent in compliance with all treatment objectives, the range of recovery efficiencies was smaller than expected at 68 to 90 percent.

Recovery efficiency for RO alternatives was projected at 69 to 76 percent. Lower recovery was projected for Alternative 1A, which included pretreatment targeted on manganese removal, while higher recovery was projected for Alternative 1B, which included pretreatment by IX softening. While both pretreatment processes will increase the RO recovery efficiency to about 90 percent, a portion of influent flow becomes secondary waste due to pretreatment system maintenance (filter bed backwash and IX resin regeneration). Alternative 1A, while producing a lower yield of treated effluent, was estimated at higher CAPEX, OPEX and NPV in comparison to Alternative 1B. At higher cost and lower treatment efficiency, further development of Alternative 1A is not warranted.

Similarly, the estimated CAPEX and OPEX for alternatives yielded a relatively tight range of 10-year NPV costs with NPVs for three of the top four alternatives falling in a range from \$7,580,000 (Alternative 4B WAIV Enhanced Solar Evaporation) to \$12,500,000 (Alternative 1A RO with Manganese Pretreatment). Excluding the NPV for the highest rated Alternative 4B, the NPVs of the second, third and fourth rated alternatives range from \$10,580,000 to \$15,150,000. Significantly higher NPVs were calculated for Alternative 2A (EC with RO polish) at \$18,180,000 and for Alternative 3 (Mechanical Evaporation with IX Pretreatment) at \$15,150,000. In the event that maximizing the amount of treated water recovery for aquifer restoration becomes a "must" in the selection of a preferred alternative, the RO and mechanical evaporation alternatives would be favored. Further development of cost estimates for Alternatives 1B and 3 would be warranted.

The treated water recovery efficiency for the EC standalone alternative (Alternative 2B) is projected at 95 percent; however, the treated effluent will not meet the treatment objectives for nitrate, sulfate, or TDS. While the sulfate and TDS objectives could potentially be negotiated, the nitrate objective is a regulatory requirement. As a partial treatment alternative, the EC standalone treatment process is not carried forward. EC with RO polishing (Alternative 2A) was estimated as the most costly alternative and was scored considerably lower than the other alternatives that are capable of producing a fully compliant treated effluent stream. Further development of Alternative 2A is not warranted.

A fully passive solar evaporation pond alternative was not carried forward due to the relatively large footprint required for a 40 gpm or 100 gpm capacity, at about 15 acres and 40 acres respectively. If such an alternative was to be developed, the availability of area beyond the fenced boundary of the Site for installation of another evaporation pond must be investigated.

Installation of a new solar evaporation pond is viable as a method to increase capacity for onsite handling of secondary waste. A twin 3-acre pond would double the Site's secondary waste handling capacity to about 20 gpm. Secondary waste generation for Alternatives 1B is projected at 24 gpm. Additional solar evaporation pond area of about 4.5 acres would be needed to handle secondary wastes from Alternative 1B. Influent distribution on the pond apron is a relatively simple evaporation rate enhancement that could reduce the additional pond area requirements.

Alternatives warranting further analysis due to their technical and cost effectiveness (Alternatives 4B, 1B, and 3) are discussed in the following section.

7.0 Recommendations and Path Forward

Development of IDB water quality and flow rates, along with treatment objectives provided the foundation for analysis of treatment technologies on a “level playing field.” Treatment alternatives were developed around the primary technologies, considering the needs for pretreatment, polishing treatment and handling of secondary wastes. Alternatives were scored against weighted criteria as described in Section 5. Alternative 4B WAIV enhanced solar evaporation was rated the highest, followed by Alternative 1B RO with IX pretreatment and Alternative 3 mechanical evaporation. The treatment objectives for aquifer water quality will be met by all of the top three alternatives. Alternative 4B will not produce a treated effluent for return to the aquifer. Alternatives 1B and 3 will produce treated effluents for return to the aquifer at efficiency rates of 76 percent and 90 percent, respectively. These alternatives can also be designed with operational capacities of 40 gpm or 100 gpm, or with the flexibility to operate at either IDB flow rate. Thus, neither the achievable quality of treated effluent nor the treatment throughput requirements proved to be differentiating factors in the identification of a preferred treatment alternative.

The significant differentiator that emerged from the alternatives analysis is the choice of technologies between:

- A simpler and lower cost treatment that releases the recovered water to the atmosphere via evaporation; or
- A more complex and higher cost treatment that maximizes the amount of water returned to the aquifer through infiltration or injection.

Therefore, the path forward for groundwater treatment at the Site will be defined by the strategic choice between operating a lower cost and less complex treatment system which returns no treated water to the aquifer or a more costly and complex treatment system that maximizes groundwater recovery.

7.1 Path Forward Groundwater Treatment with No Recovery of Treated Effluent

The most viable treatment alternative is WAIV-enhanced solar evaporation. It is a relatively low-cost, low-maintenance process that takes full advantage of the Site’s optimal climate for natural evaporation and is compatible with the existing solar evaporation pond. Conceptual design prepared by the equipment supplier, Lesico Clean Tech, indicates that the Site’s existing solar evaporation pond is of adequate size to serve as the WAIV process collection pond for a 100 gpm system, with minimal modification. Maintenance requirements for the WAIV process are dependent on water quality, flow rate, and climate and need to be further developed with the assistance of Lesico Clean Tech. The supplier’s conceptual process development indicates that the textile sheets can be cleaned with a sodium chloride solution or a weak acid (citric or sulfamic acid in a 1 percent solution) and that cleaning may be required on a weekly to biweekly basis. The textile sheets are expected to have a useful lifespan of 5 to 7 years. The WAIV technology’s modular design lends itself to pilot testing. A single module could be placed onsite to collect data, including evaporation efficiency and cleaning requirements. A year-round pilot operation would provide understanding of maximum and minimum evaporation rates.

7.2 Path Forward Groundwater Treatment Maximizing Recovery of Treated Effluent

RO Alternative 1B and mechanical evaporation Alternative 3 are both projected to produce a treated effluent meeting all treatment objectives, which can be returned to the aquifer by either infiltration or injection. Should the decision be made that return of treated water to the aquifer resource is of primary concern and is a higher priority than operation of a simpler and lower-cost solution that does not return any water to the aquifer, the treatment alternative 1B or 3 would be preferred.

The long-term behavior (membrane cleaning cycles, membrane replacement requirements, gradual changes in contaminant rejection, and permeate recovery) of an RO treatment process can best be projected through execution of a pilot test with a duration at least through the first cleaning cycle. The pilot would be best conducted onsite over a time period of up to 1 year. If a 1-year pilot test is not feasible due to project scheduling constraints, moving forward with the RO alternative would present some cost risk. Treated effluent quality would not be an issue, as RO is a well-proven technology, but a more accurate estimate of operational cost (dependent on membrane cleaning cycle frequency and membrane replacement) can only be determined through pilot testing.

The quality and reliability of mechanical evaporation equipment has improved in the past 10 years, the time since a relatively unreliable evaporator was installed onsite. These improvements to reliability are due to the use of stainless steel heat transfer surfaces rather than plastic cartridges, use of standardized designs and components, change in configuration from compact cartridges to towers, and general improvements in control systems and equipment. Pre-engineered, skid-mounted mechanical evaporators are available from multiple suppliers. Suppliers of mechanical evaporation equipment today will also have the advantage of better understanding the groundwater quality and the challenges it has presented for the existing mechanical evaporation system. Treated water recovery for mechanical evaporation is considerably higher than for the RO alternatives. Mechanical evaporation would require less pilot testing than RO and could potentially meet a tighter schedule deadline for having a new, fully operational system onsite.

The groundwater treatment strategy to maximize the amount of water returned to the aquifer can be further developed through more-detailed comparison of Alternatives 1B (RO with IX softening pretreatment) and 3 (mechanical evaporation). System designs could be taken to a 30 percent level of completion, allowing for more accurate estimates of CAPEX, OPEX, and life-cycle costs. RO will require pilot testing, whereas mechanical evaporation may not.

Scoring of matrix criteria at the conceptual level of design is necessarily subjective. While scoring at this level can be used to compare, rank, and advance a short list of preferred alternatives, the scores and criteria weights are based on engineering judgment, open to reconsideration depending on stakeholders' priorities. With a more advanced design (including process flow diagrams, mass and energy balances, equipment sizing and general arrangement plans, preliminary piping and instrumentation diagrams, and controls philosophy), the objectivity of the analysis would be greater. Safety analyses such as failure modes and effects analysis (FMEA) or hazards and operability study (HAZOPs) could be performed. These types of study

support more-definitive scoring of several matrix criteria, including safety, operability, and flexibility. Reliability, availability, and maintainability data should be available from equipment suppliers and should be requested when the requisite level of design detail is established.

This page intentionally left blank

8.0 References

40 CFR 192. "Health and Environmental Protection Standards for Uranium and Thorium Mills," *Code of Federal Regulations*.

ADEQ (Arizona Department of Environmental Quality), undated. *Arizona Mining Guidance Manual BADCT*, Publication No. TB 04-01.

ADWR (Arizona Department of Water Resources), 2011. "*Arizona Water Atlas, Volume 2: Eastern Plateau Planning Area*," <http://www.azwater.gov/AzDWR/StatewidePlanning/wateratlas/default.htm>, Accessed July 18, 2014.

Bureau of Reclamation, 2009. *Brine-Concentrate Treatment and Disposal Options Report, Southern California Regional Brine-Concentrate Management Study – Phase 1, Lower Colorado Region*.

DOE (U.S. Department of Energy), undated. *Geospatial Environmental Mapping System*, Version 2.1.6, Tuba City, Arizona, Disposal Site, Office of Legacy Management.

DOE (U.S. Department of Energy), 1999. *Phase I Ground Water Compliance Action Plan for the Tuba City, Arizona, UMTRA Site*, U0027401, U.S. Department of Energy, Grand Junction Office, June.

DOE (U.S. Department of Energy), 2011. *Tuba City, Arizona, Disposal Site Fact Sheet*, Office of Legacy Management, December.

DOE (U.S. Department of Energy), 2012a. *Tuba City, Arizona, Disposal Site Treatment System Description Document*, LMS/TUB/S08589, Office of Legacy Management, January.

DOE (U.S. Department of Energy), 2012b. *Annual Groundwater Report April 2011 through March 2012 Tuba City, Arizona, Disposal Site*, LMS/TUB/S08999, Office of Legacy Management, July.

DOE (U.S. Department of Energy), 2013. *Annual Groundwater Report April 2012 through March 2013 Tuba City, Arizona, Disposal Site*, LMS/TUB/S10107, Office of Legacy Management, August.

DOE (U.S. Department of Energy), 2014. *Statement of Work – Alternative Analysis of Contaminated Groundwater Treatment Technologies, Tuba City*. LMS/TUB/S11484, Office of Legacy Management, February.

Golder (Golder Associates Inc.), 2014a. Technical Memorandum, *Groundwater Treatment Technologies Alternative Analysis*, kickoff meeting and site visit notes, May 5.

Golder (Golder Associates Inc.), 2014b. Technical Memorandum, *Influent Design Basis for Tuba City Groundwater Treatment*, June 25.

Golder (Golder Associates Inc.), 2014c. *Work Plan for Bench-Scale Treatability Testing*, May 12, revised May 29.

Golder (Golder Associates Inc.), 2014d. Technical Memorandum, *Treatability Testing Results for Tuba City Groundwater Treatment*, July 14.

Golder (Golder Associates Inc.), 2014e. Email communication (about wind-aided intensified evaporation [WAIV] cleaning requirements and textile sheet lifespan, September.

Hoque, S., Alexander, T., Gurian, P., 2010. “Innovative Technologies Increase Evaporation Pond Efficiency,” *International Desalination Association Journal*, First Quarter 2010.

Lesico Cleantech, 2014. Email communication (about wind-aided intensified evaporation [WAIV] conceptual design) with Nissim Asaf, July.

Lide, David R., 1995, *Handbook of Chemistry and Physics*, 82nd edition, CRC Press.

Linsley, R.K., and Franzini, J.B., 1972. *Water Resources Engineering*, 2nd edition, McGraw-Hill Inc., New York, New York.

MACTEC (Mactec Environmental Restoration Services, LLC), 1998. *Final Site Observational Work Plan for the UMTRA Project Site near Tuba City, Arizona*, U.S. Department of Energy Albuquerque Operations and Grand Junction Offices, U0017501, September.

NOAA (National Oceanic and Atmospheric Administration), 2014. “National Climatic Data Center of the National Oceanic and Atmospheric Administration,”

<http://www.ncdc.noaa.gov/climate-information/climate-us>, accessed July 18, 2014.

Powell (Powell Water Systems Inc.), undated. *50 GPM EC System Operation Manual*, undated.

Snyder, R.L., and Eching, S., 2006. *Penman-Monteith daily (24-hour) and Hargreaves-Samani Equations for Estimating Reference Evapotranspiration from Monthly Data*, Regents of the University of California, revised 2006.

Stoller (The S. M. Stoller Corporation, a wholly owned subsidiary of Huntington Ingalls Industries), 2014. *Tuba City Treatment Plant Production Performance 4-6-14*. Excel spreadsheet, April 6.

USGS (U.S. Department of the Interior, U.S. Geological Survey), 2012. *Estimation of Evaporation from Open Water – A Review of Selected Studies, Summary of U.S. Army Corps of Engineers Data Collection and Methods, and Evaluation of Two Methods for Estimation of Evaporation from Five Reservoirs in Texas*, Scientific Investigations Report 2012-5202, 2012.

Attachment A

Site Visit Report

This page intentionally left blank



MEMORANDUM

Date: May 5, 2014 **Project No.:** 1401485
To: Ken Karp **Company:** SM Stoller Corp
From: Peter Lemke
cc: Troy Thomson, Scott Smith, Alan Smith, Bridgette Hendricks, Bryan Moravec
RE: **GROUNDWATER TREATMENT TECHNOLOGIES ALTERNATIVE ANALYSIS** (revised)

A kickoff meeting and site visit for the groundwater treatment technologies alternative analysis was held on April 22, 2014, at the Tuba City Disposal Site. The attendees were:

Name	Affiliation	Project Role
Ken Karp	Stoller	Stoller's project manager
Troy Thomson	Stoller	West operations manager
Scott Smith	Stoller	Tuba City site manager (outgoing site operations manager)
Alan Smith	Stoller	Tuba City site operations manager (incoming)
Bridgette Hendricks	Golder	Lead process engineer
Bryan Moravec	Golder	Subject matter expert – evaporation
Pete Lemke	Golder	Golder's project manager

A safety briefing was provided by Scott Smith for the Golder visitors. Combined Stoller and Golder notes of the meeting and site observations include:

- Ftp site set up by Stoller – Pete downloaded all files from the ftp to Golder's network, to which other Golder staff have full access. When future uploads are made, it will be better for all Golder staff to go directly to the ftp. All users must have most current version of Java installed for easiest (drag and drop) functionality of the ftp site. Pete will provide the ftp username and password to everyone on the Golder team.
- AutoCAD drawings of the evaporation pond are on the ftp.
- Groundwater plume/extraction wells:
 - The highest producing extraction wells are at the toe of the disposal cell.
 - There are 37 extraction wells. About a dozen of these combined, will produce at a rate of 80 to 100 gallons per minute (gpm).
 - Groundwater modeling indicates that the plume could daylight at the Moenkopi Wash in 300 to 1,000 years. Groundwater modeling is in progress.
 - Extraction well vault for EW 1122 was observed. Sample ports are available at all EWs. Well pumps are equipped with pump savers, and are automatically controlled (on/off, not vfd).
 - Our report is to be focused on treatment, but recommendations for wellfield operations will be welcomed.



MEMORANDUM

- Mechanical vapor recompression (MVR) evaporator:
 - Evaporator is operated under vacuum, reducing the boiling point of water to about 140°F.
 - Two banks of 24 cartridges provide surface area for evaporation. Replacement cartridges will not be available for much longer. Cost of complete replacement is about \$250K.
- Treatment headworks – has a sample port. A blended sample can be obtained here. If specific wells are identified for blending, they could be turned on and a sample collected when the main pipeline has been purged of flow from other wells.
- Feed tank – provides surge capacity and allows for overnight unattended operation. Tank volume is 20,000 gallons and is level-controlled. At 70% level, the feed pump is automatically turned on. At 80% level, the feed pump is turned off. The suction line (leaving the feed tank, into treatment process) is very low on the tank. There is very little sediment accumulation at the bottom of the feed tank.
- Salt silos – saturated salt solution in silos is used for ion exchange (IX) resin regeneration. Low-grade salt is used. Concentration is manually monitored twice a day. If concentration is less than 98% of saturation, they switch from one silo to the other. Consider potential for automation here. Plant operation is at risk at night if IX pretreatment is part of the new system.
- Infiltration tank and trench, north of the treatment plant close to the highway. Trench is a reverse French drain at 8 feet bgs fed by gravity flow. Injection wells are installed but are not in use.
- Photovoltaic array – 285 kW new system plus 51 kW old system provides up to 30 percent of the treatment plant power.
- Solar concentrator – glycol is heated by solar concentrator. Hot glycol is used to heat water. The client is interested in “green” and efficient technologies. The concentrators are designed to automatically track the sun, but there's a problem with controls – they need to be reset every morning. The solar concentrator was not functioning during the site visit.
- Ion exchange (IX) system – added to eliminate scaling problems in the evaporator.
 - Two upflow columns in parallel, regeneration is automatically started when one column has processed 18,000 gallons. Salt (NaCl) is used for regeneration. Saturated salt solution (26%) is stored in external salt silos – diluted to 12-15% prior to use as regenerant solution. When the treatment system is fully operational, columns regenerate every four to six hours. Spent regenerant goes to the evaporation pond onsite.
 - A cation exchange resin (Dow) is used. Resin replacement is on a five-to-seven year frequency. Spent resin is disposed in the evaporation pond onsite.
 - If IX is needed in the new treatment system, we should consider a new skid mounted system or adding a third column and completely overhauling and upgrading the instrumentation and controls system.
 - Maintainability is a high priority criterion for alternative assessment (matrix evaluation).
- Acid tank – new in 2011. Concentrated sulfuric acid. 2,700 gallons storage capacity. If the new treatment process requires use of acid, this tank should be used.
 - Safety is also a high priority criterion for matrix evaluation.



MEMORANDUM

- Evaporation pond – water management. In summer, the pond could go to dryness. Level has to be maintained in order to prevent dust/sediment from pond bottom becoming airborne. A higher level is maintained in winter due to lower evaporation rate and to have some inventory for dryer season.
 - Pond is double-lined and equipped with a sump to collect leak water. Very minimal amount of water accumulates in the sump. It is occasionally pumped out and returned to the pond.
 - If a second pond is needed, there is space available to the west of the existing pond (in the direction of the disposal cell).
 - At completion of groundwater remediation, the pond will be allowed to go to dryness, and solids will be mucked out for offsite disposal. For alternative analysis, this will be the same for all options. The only secondary waste issues to consider would be for any wastes that could not be disposed in the pond.
 - Pond is regulated under UMTRA, so only process solutions can be transferred to the pond.
 - Gypsum accumulation in the pond is one of the key drivers for alternative analysis.
 - Pond is sampled at two points (sample IDs 1569 and 1570), twice per year for annual reporting.
 - pH sometimes dips low (2.5), possibly due to wind/rain/turnover sediments mixing and affecting pH.
 - Sediment depth in the pond has not been measured.
 - One potential benefit with respect to pond operation – if the existing IX system can be eliminated, the salt loading to the pond will be reduced (no disposal of IX regenerant).
- Stakeholder and other issues:
 - Energy efficiency and return of treated water to the aquifer were high priorities when the treatment system was originally installed. The Navajo Nation prefers treated groundwater to be returned to the aquifer. They view passive solar (pond) evaporation as a loss of valuable water.
 - Plume movement (300 to 1,000 years before daylighting in Moenkopi Wash) is considered as the technical basis to monitor with no treatment.
 - Overall carbon footprint could be considered in analysis – treating for high recovery and high quality might be best for the aquifer but could have many other environmentally negative impacts – trucks hauling chemicals, higher energy use, greater personnel safety/environmental hazards.
 - Two bounding strategies for groundwater extraction – maximum pumping with maximum return of treated water to the aquifer (remediation); or minimum pumping to control plume migration (containment). The containment strategy could involve pumping from a limited number of wells, based on contaminant loads and best extraction flow rates.
 - Flexibility of the treatment system will be important in alternative analysis. The system should be capable of handling a maximum flow rate of 100 gpm, with turn-down capability to 30 gpm. A 20 percent safety/flexibility factor on maximum flow (120gpm) could be considered in the analysis.



MEMORANDUM

- Control room:
 - RSLogix 500.
 - Wonderware.
 - SLC 5 Allen-Bradley processor.
 - Old control technology – assume that a completely new control system will come with the new treatment system.
 - Stoller wants control room HMI (similar to what they have now) and capability for remote monitoring and control.
 - Trending capability is a desirable control system upgrade.
 - Stoller is comfortable with Allen-Bradley, but would not preclude other PLC manufacturer(s).
- Discussion – after site walk:
 - Ken provided a plot of uranium mass loading and water production from individual wells. Additional plots (nitrate, sulfate) can be generated. Plots can be used to guide the blending of bulk sample for bench testing.
 - GEMS – Legacy Management public webpage has water quality data.
 - Reverse osmosis (RO) options: bound the RO system evaluation with:
 - A very basic RO system, with minimal pre- and post-treatment. The basic RO option will provide a lower bound for permeate recovery and effluent quality, but will have the lowest capital and operating expenses (CAPEX and OPEX).
 - A “Cadillac” RO system, with pretreatment steps leading to optimum RO recovery and quality, and post-treatment if necessary to ensure that all treatment goals are met. This system would also include treatment of secondary waste (RO brine) for incremental improvement in water recovery and minimization of secondary waste volume. The Cadillac system will have the highest CAPEX and OPEX but will return the maximum amount of high quality effluent.
 - A “middle of the road” RO system – balancing cost and treatment efficiency.
 - Mechanical evaporation option – this option will consider use of an evaporator in the same “technology family” as the existing unit.
 - Electrocoagulation (EC) – consider as a pretreatment step, main treatment (possibly requiring a polishing process to meet effluent goals) and as an RO brine treatment process.
 - EC vendor Baroid has been in contact with Stoller. Stoller provided Baroid information to Golder. Golder will contact Baroid as part of the EC evaluation.
 - Passive treatment – biochemical reactors (BCRs) could be viable for uranium and nitrate removal. BCRs will not effectively remove sulfate or total dissolved solids (TDS). **Golder action – get BCR paper to Ken.**
 - RO bench testing plan – operate RO anticipating 60-70 percent permeate recovery. Sample and analyze influent, permeate and brine for initial indication of water quality that can be achieved by RO. Generate enough volume of RO brine for a series of EC bench tests.



MEMORANDUM

- The RO bench will not provide information about cleaning cycles or membrane life. Golder will discuss with RO suppliers to develop estimates of cleaning and membrane replacement cycles for estimate of RO OPEX.
- Potential hazards presented by RO cleaning chemicals – hazards of delivery and operator exposure risk. RO clean-in-place (CIP) capability will be included, limiting operator exposure. CIP chemicals may include acid, base, and/or an organic chemical.
- Recent well development (cleaning) “chimney brush” and pulsed pumping to clean out sediments.
- Previous RO test – test plan and additional information on a 2-month (?) RO test can be uploaded to the ftp. Contact information for Stoller’s lead on the RO test can be provided.
- Current plant staffing – 2 or 3 operators are onsite for a 10-hour day shift, seven days per week. The site supervisor and process engineer are onsite Monday-Friday on a normal full-time schedule.
- Target treatment goals – Uranium, nitrate, molybdenum, and selenium are regulatory aquifer restoration standards of 40 CFR 192 and sulfate, TDS, chloride, and pH are aquifer restoration goals that were agreed upon with the Navajo Nation. There is some “flexibility” in the non-regulatory parameters.
- Enhanced evaporation options:
 - Membrane distillation – developmental stage, will not be evaluated.
 - Wind-Aided Intensified eVaporation (WAIV) “sailcloths” suspended in a rack with water trickled through can increase evaporation rate 15x over pan evaporation.
 - Spray evaporation – issues with windborne overspray, but do not eliminate from consideration.
 - Existing pond, as is – “keep it simple.”
 - Aluminum fins – increase thin film evaporation surface area, but would eventually have to be disposed as rad waste.
 - Discussion of outdoors evaporation options should clearly document airborne transport issues – avoid drift outside footprint of pond.
 - Sparging – is power-intense and does not increase evaporation efficiency by a whole lot.
- General discussion of “green technologies”. **Golder will include a technologies screening table in the report, with technology description, advantages and disadvantages.** While screening might not require a retain/reject decision, the table will allow Stoller and client to see what was considered, outside of the scope requirement for conventional – off-the-shelf technologies.
- Solar concentrator could potentially be used as an influent preheater for RO treatment. Groundwater temperature is typically 60°F, and if it could be heated to 85°F RO efficiency will be greatly increased,
- Bench testing for conventional mechanical evaporation. Most vendors do not need to run a bench test if a good water quality characterization is available. A boildown test could be run, but presence of uranium might present problems for vendor testing. **Golder will contact evaporator vendors to potentially provide guidance for a boildown test to be performed at Hazen.**



MEMORANDUM

- Volume and blend of bulk water sample for bench testing – **Golder to provide guidance to Stoller, targeting second week of May to have water at Hazen for bench testing.**
- Discussion of design parameters referenced in RFP:
 - 100 gpm max flow, 30-80 gpm nominal. RO turn-up/down range is not great. RO modules with capacity of 30 gpm and 70 gpm could be used to provide the flow rate flexibility range.
 - The existing extraction and injection systems will not need to be considered in alternative analysis.
 - Enclosure – assume all processes are inside a sea-land container or in a building (Sprung Structure is a possibility).
 - Assume that the existing headworks and 20,000-gal feed tank will be used for the new system.
 - Existing power supply should be more than adequate. **Stoller will upload electrical one-lines and P&IDs to the ftp.**
 - Process equipment – assume all new, including pipe, valves, fittings, I&C, PLC. The existing IX system could potentially be refurbished for use in the new system.
 - The treatment systems should be turn-key packages.
 - Power distribution will be part of the alternative design(s). Stoller/site will provide one main breaker.
 - PLC should be industry standard – good availability of replacement/upgrades for 5-10 years is the goal.
 - Operations – capability for 24/7 unattended operation is needed. Remote access to PLC is needed – for control from offsite if necessary.
 - Onsite labor – always at least two operators (buddy system).
 - Matrix evaluation criteria – maintainability, reliability, availability, inspection/troubleshooting, process complexity, environmental factors (airborne transport, generation of hazardous secondary waste, treated effluent that does not meet all goals).
- Bulk sample – is analysis before shipping required by shipper or by Hazen? **Golder to discuss with Hazen.** Hazen has already indicated that the uranium expected to be present in 100 gallons of water will not be a mass problem for their radioactive materials license. **Golder will give Stoller a target date for shipment and Stoller will work toward it.** Use of surrogate water was briefly discussed and dismissed.
- For the RO bench testing the concentrations of manganese and silica will be operationally important. **Golder will review GEMS data and inform Stoller if the bulk blending should be altered to avoid wells with higher Mn concentrations.**
- Reporting requirements – annotated outline, draft and final.
 - Cost of equipment lease vs. purchase should be considered. It is unlikely that a ten-year lease will provide a cost benefit, and with the radioactive component, the site will effectively buy and own the equipment regardless.



MEMORANDUM

- Provide a bench test plan, including QA/QC for analytical and corporate QA policy statement.
- Provide an influent design basis document.
- Model outputs (ROSA, RO antiscalant, PHREEQ-C or Geochemist Workbench) should be provided as report attachments.
- Thorough technical editing of all deliverables is very important.
- Discussion of a phased implementation to the full-scale treatment system, as opposed to pilot testing was discussed. The evaporator installation was essentially a phased full-scale process development, when the need for IX pretreatment was realized. The cost and duration of a fully informative pilot may be prohibitive. Modeling and bench work could provide adequate basis for “full-scale piloting”.
- Is there a goal to maintain some level of staffing? A fully passive evaporation system would potentially require minimal reconnaissance and monitoring. Onsite staff would be greatly reduced.
- General scope/schedule for bench activities:
 - Day one – run RO, collect permeate and brine samples for analysis, generate an adequate volume of brine for EC testing.
 - Day two – EC testing on raw water and RO brine. Trials will include variation of residence time, blade types, and influent pH (adjusted in lab).
 - Hazen’s mob/demob is included in their cost, and will not impact the two-day test schedule.
- Additional cost for RO bench will be estimated. A change request for additional analytical and additional labor hours will be prepared.
- **Based on our understanding coming out of the site visit, Golder will provide a revision to the proposed milestone schedule.**
- A weekly or biweekly project status call will be scheduled.

This page intentionally left blank

Attachment B

IDB Technical Memorandum

This page intentionally left blank

Date: June 25, 2014
To: Mr. Ken Karp
From: Bridgette Hendricks, Karen Budgell
cc: Pete Lemke
Project No.: 140-1485
Company: S.M. Stoller Corporation
Email: Bridgette_Hendricks@golder.com
RE: INFLUENT DESIGN BASIS FOR TUBA CITY GROUNDWATER TREATMENT

1.0 INTRODUCTION

Golder Associates Inc. (Golder) has been engaged by S.M. Stoller Corporation (Stoller) to provide a groundwater treatment alternative analysis for the U.S. Department of Energy's (DOE) legacy site (the Site) near Tuba City, Arizona. This technical memorandum provides a summary of the influent design basis (IDB). The IDB serves as a common basis for the technology evaluation and includes water quantity, water quality and treatment objectives. The IDB includes the parameters referenced in the Statement of Work (SOW) provided with the request for proposal (Stoller, LMS/TUB/S11484, February 2014) and other constituents that may affect the development of treatment trains, operational parameters, or achievable removal efficiencies for parameters with specified treatment objectives. The following sections describe IDB water quantity, water quality, and effluent treatment objectives.

2.0 WATER QUANTITY CHARACTERIZATION

The IDB water quantity characterization represents the flow rate flexibility that will be considered in treatment technologies analysis. Two groundwater flow scenarios are developed per the SOW including:

- Control of plume migration and contamination "hot spots" (lower flow, but higher parameter concentrations); and
- Aquifer restoration (higher flow, lower parameter concentrations).

Continuous flow rates for these two scenarios (as presented in the SOW) are 40 gallons per minute (gpm) and 100 gpm, respectively, and will be used for treatment equipment sizing and estimation of capital, operating and life cycle costs.

Flexibility to operate in continuous or batch mode will also be considered. Continuous flow may be advantageous if the system can be automated for highly reliable unattended operation. A variety of batch flow scenarios, allowing for overnight and/or weekend shutdowns may be advantageous if the cost of process automation is prohibitive. In order to treat the same volume of water over a time-averaged basis, the batch flow rates would be higher than continuous flow rates.



3.0 WATER QUALITY CHARACTERIZATION

The IDB water quality characterization is based on Site operating data, analytical results from bulk water samples collected for bench scale treatability testing and historical water quality data from individual monitoring and extraction wells. An overview of these data sets and development of IDB water quality from analysis of each set individually and in comparison with each other are presented in the following sections.

3.1 Site Operating Data

A summary of Site operating data from the SOW (Stoller, February 2014) is presented in Table 1. All parameters with defined effluent treatment objectives are summarized, along with additional parameters that do not have treatment objectives but impact operation of the current treatment system.

3.2 Bulk Sample Analytical Results

Analytical results from “raw” bulk (100-gallon) samples are presented in Table 2. Bulk samples were collected for use in bench-scale treatability testing of reverse osmosis and electrocoagulation processes. The first bulk sample was collected on May 1, 2014 and after shipment to the testing laboratory (Hazen Research in Golden, Colorado), it was found to be high in sodium and chloride concentrations. Subsequent investigation by site operations personnel showed that the extraction wells were not operating when the sample was collected. The sample consisted of backflow from the influent feed tank and there was an equipment malfunction allowing backflow of regenerant salt solution to the headworks sample port. In addition to non-representative concentrations of sodium and chloride, this sample had lower than normal concentrations of calcium and magnesium. Other parameters (metals and common anions) were present at concentrations representative of historical averages.

Due to the non-representativeness of the first sample, a second bulk sample was collected on May 13, 2014. The sample was drawn while the extraction well pumps were running at a total influent flow rate of 104 gpm. The conductivity of the sample was measured at the site as an indicator for the sample’s representativeness of groundwater quality.

Analytical results for the second bulk sample are representative of current groundwater conditions and provide a baseline for bench-scale treatability evaluation of contaminant removal efficiencies. The non-representativeness of the first bulk sample was accounted for, and other than the concentrations of sodium, chloride, calcium and magnesium, all other parameters were representative of groundwater quality. Non-regulated parameters such as alkalinity, manganese, and silica were also analyzed. While these parameters do not present operational issues for the Site’s current treatment system, they may present issues for the alternative technologies.

3.3 Historical Data for Extraction Wells

To understand potential changes in groundwater quality over time, the DOE Geospatial Environmental Mapping System (GEMS) online database was utilized. Groundwater quality data for the years 2000 to 2014 were reviewed. Sampling was generally conducted on an annual basis, with some wells being sampled more frequently. The analytical suite for GEMS routine groundwater monitoring and data is more extensive than the Site operating data. Data presented in Table 3 are the average constituent values for the fourteen highest producing extraction wells. The concentrations for each of the individual wells are presented as:

- Simple average (average over time of the average values);
- Maximum of the average values; and
- Flow weighted average accounting for each well's constituent load contribution to the total flow.

These three values are shown for each parameter on Table 3 under the "Statistical Summary" heading. Observations regarding the GEMS data review include:

- No apparent trends of concentration changes by well were observed, with the following exceptions:
 - The molybdenum concentration decreased by an order of magnitude in four of the fourteen high flow wells (1105, 1121, 1120, and 1106).
 - The selenium concentration showed a similar decrease in wells 1105, 1120, and 1121.
 - The uranium concentration decreased in wells 1005, 1120, 1121, and 1122. It should be noted that the uranium concentration increased in well 1104 from 0.2 mg/L, prior to 2004, near 1 mg/L since 2008.
- Concentrations of common cations (sodium, calcium, magnesium) and anions (sulfate, nitrate, carbonate, chloride) showed little variability throughout the wellfield. The pH values are also fairly consistent.
- Manganese, molybdenum, and uranium showed the greatest variability in concentrations, from well to well.
- Historical flow weighted average concentrations shown on Table 3 are comparable to the values presented in Tables 1 and 2 except for molybdenum; the historical average for molybdenum is an order of magnitude higher than the current value and the historical maximum concentration for molybdenum is two orders of magnitude higher than the current value shown on Table 2.
- Averaging by flow-weighting the well average values did not provide a significantly different result than simply averaging well-to-well average concentration values.

3.4 IDB Water Quality Development

A comparison of the three water quality data sources described above is presented in Table 4. The objectives for evaluating multiple data sets include:

- Expanding the characterization beyond the parameters provided in the SOW, to ensure that alternative technologies can be accurately conceptualized and fairly evaluated;

- Determining if changes in water quality might be expected over the operating life of the new treatment system; and
- Determining if any particular parameters might be attributed to a specific well.

Analytical results obtained from the second bulk influent sample provide a more complete water quality characterization, necessary for comparison of the existing treatment system and alternatives. Laboratory quality control calculations (cation/anion balance) show these data to be very reliable.

Review of GEMS data showed no increasing or decreasing concentration trends over a period of the past fourteen years with the exception of molybdenum, selenium, and uranium as discussed above. GEMS data also showed parameter concentrations to be fairly consistent throughout the wellfield, revealing no particular advantage to modifying the extraction well operations routine.

Comparison of the data sets reveals that the water quality characterization from the bulk influent sample is representative of long-term groundwater conditions. IDB concentrations for individual parameters have been selected from two data sets: the historical average values and the analytical results from the second bulk sample. To provide a conservative estimate of the influent water quality the higher of the two values for each parameter is used.

4.0 EFFLUENT TREATMENT TARGETS

The Site groundwater treatment objectives, as documented in the SOW, are shown on Table 5. These values include federal regulatory limits from “*Health and Environmental Protection Standards for Uranium and Thorium Mill Tailings*” (40 CFR 192) and several site-specific effluent treatment objectives.

5.0 IDB SUMMARY

Table 6 summarizes the IDB constituent concentrations, treatment objectives, and removal efficiencies required to meet the treatment goals. The IDB concentrations reflect the current groundwater state and conservatively represent the long-term groundwater condition. Parameters which require treatment include molybdenum, nitrate, selenium, sulfate, total dissolved solids and uranium. It should be noted that the molybdenum concentrations in the influent are currently below the treatment standard; however, the more conservative molybdenum value has been used to include molybdenum for technology evaluation purposes.

There is also a treatment objective for chloride, which could potentially be exceeded through addition of chloride containing process reagents. For example, if hydrochloric acid is added for effluent pH adjustment, the chloride concentration would be increased. So although chloride is not present in groundwater at a concentration requiring removal, its treatment objective concentration should be considered as treatment alternatives are developed.

The flow rates as specified in the SOW will be used for the IDB. The differences in parameter concentrations for the 40 gpm and 100 gpm scenarios will not impact technology screening, the development of treatment alternatives, or their capability to meet the treatment objectives. The higher concentrations expected at the 40 gpm scenario (plume containment only) will impact the operational costs due to higher reagent requirements and residual production per volume of water treated. The water quality differences between the 40 gpm flow scenario and the 100 gpm flow scenario will be incorporated into the alternatives evaluation during cost development. Flexibility for continuous and batch operation will be considered as part of the flow rate IDB as will the recovery of treated effluent aquifer restoration.

TABLES

Table 1: Summary of Influent Operating Data Provided in RFP¹

Parameter	Units	Groundwater Flow	
		100 gpm	40 gpm
Sulfate	mg/L	1,500	2,000
Chloride	mg/L	75	100
Nitrate	mg/L	400	500
Nitrate	mg/L as N	90	113
Uranium	mg/L	0.35	0.45
TDS	mg/L	3,000	4,000
Calcium	mg/L	400	500
Ammonia	mg/L as N	13	17
pH	SU	6.6	6 to 7
Conductivity	uS/cm	3,500	4,500

¹ The 100 gpm concentrations are based on the weekly concentration measurements of the raw feed water at the existing groundwater treatment plant. The 40 gpm concentration values were calculated and intended to represent a weighted average based on only the wells in the "hot spot" needed to contain the plume.

Table 2: Received Water Quality from Existing Water Treatment Plant Influent

Parameter	Units	5/1/2014 ¹		5/13/2014 ²		5/13/2014 (Dup) ³	
Total Alkalinity (CaCO ₃)	mg/L	380		350		360	
pH	SU	6.89		7.2		7.06	
Conductivity	umhos/cm	50700		3890		3860	
TDS	mg/L	21000		3400		3700	
TSS	mg/L	<20		<20		<20	
Fluoride	mg/L	<5		<0.2		<0.2	
Chloride	mg/L	11000		100		100	
Nitrate (as N)	mg/L	100		100		100	
Ammonia (as N)	mg/L			19		19	
Phosphorus	mg/L			0.059		0.21	
Sulfate	mg/L	1700		1600		1600	
		Total Recoverable	Dissolved	Total Recoverable	Dissolved	Total Recoverable	Dissolved
Aluminum	mg/L	<0.05	<0.05	<0.05	<0.05	<0.05	<0.05
Arsenic	mg/L	0.081	0.074	0.052	0.058	0.054	0.054
Barium	mg/L	0.02	0.019	0.039	0.039	0.037	0.04
Calcium	mg/L	170	160	460	440	440	450
Iron	mg/L	0.1	0.1	<0.1	<0.1	<0.1	<0.1
Magnesium	mg/L	54	52	170	160	160	170
Manganese	mg/L	2.2	2.1	6.2	6	5.9	6.1
Molybdenum	mg/L	0.13	0.12	0.076	0.081	0.077	0.079
Potassium	mg/L	6.2	6.1	8.7	8.7	8.5	8.7
Selenium	mg/L	0.026	0.025	0.027	0.025	0.025	0.029
Sodium	mg/L	8000	7600	260	260	250	260
Strontium	mg/L	1.5	1.4	4	3.9	3.8	4
Uranium	mg/L	0.52	0.51	0.51	0.53	0.51	0.53
Silica	mg/L	14	13	15	16	15	16

¹ This sample was collected at the influent to the existing treatment plant when the extraction well pumps were not running. The sample included a mixture of backflow from the Feed Tank and sodium chloride regenerant solution. The presence of regenerant solution in the influent sample is indicated by the high concentrations of sodium, chloride and TDS. The data is included to show that all other parameters were unaffected by the regenerant contamination and are typical of Site groundwater quality.

² This sample was collected with the extraction wellfield in normal operation at a total influent flow rate of 104 gpm.

³ It appears that the dissolved and total recoverable metals samples were switched during the RO testing at Hazen, as the dissolved concentrations are all equal to or slightly higher than the total concentrations. The discrepancy is not expected to impact data validity as virtually all of the metals present are in the dissolved form. This is a duplicate sample and there is good correlation with the original sample values.

Table 3: Summary of Historical Data (2000-2014) from GEMS Database - Average Values by Well ¹

Well ID	Well Flow ² gpm	Alkalinity mg/L as CaCO ₃	Ammonia mg/L as N	Calcium mg/L	Chloride mg/L	Iron mg/L	Magnesium mg/L	Manganese mg/L	Molybdenum mg/L	Nitrate mg/L as N	Nitrate mg/L as NO ₃	pH s.u.	Selenium mg/L	Silica mg/L	Sodium mg/L	Specific Conductance umhos/cm	Strontium mg/L	Sulfate mg/L	TDS mg/L	Uranium mg/L
1105	6	368	12.38	412	85	0.013	152	0.39	1.588	115	510	6.7	0.062	14.5	265	3,613	3.11	1345	3185	1.48
1103	5	577	23.09	590	124	0.323	303	8.56	0.003	256	1135	6.4	0.042	17.3	334	5,444	4.60	2068	4866	0.368
1101	7	357	1.36	441	108	0.018			0.001			6.7	0.027	16.0		3,305	3.82	1223	2935	0.317
1104	3	423	33.82	459	120	0.116	222	1.42	0.06	192	851	6.5	0.031	16.0	291	4,494	2.72	1622	3853	0.439
1102	4	380	1.28	595	142	0.012	163	0.84	0.001	157	697	6.6	0.020	16.6	221	3,878	5.33	1418	3502	0.507
1121	4	341	23.77	378	70	0.12	172	32.38	0.067	99	437	6.6	0.027	18.9	314	2,727	2.37	1832	3390	0.531
1120	3	348	23.03	441	92	0.045	208	23.58	0.049	103	458	6.6	0.032	19.5	322	4,140	2.79	2017	3865	0.627
1108	5	686	38.55	561	91	0.385	334	10.64	0.001	215	952	6.4	0.038	17.6	231	4,838	6.79	2055	4475	0.466
1106	2	294	16.68	269	65	0.012	66	0.04	0.57	97	429	6.9	0.058	13.9	184	2,494	2.24	751	1908	1.331
1119	2	364	12.11	421	103	0.034	170	4.63	0.005	113	499	6.6	0.024	17.1	235	3,623	2.99	1379	3160	0.341
1122	1	464	13.36	503	119	0.215	222	7.01	0.001	172	763	6.4	0.039	17.6	406	4,626	3.76	2167	4029	0.537
1111	4	400	10.21	443	56	0.34	164	3.05	0.001	122	539	6.6	0.017	15.8	143	3,180	5.57	1180	2983	0.189
1109	3	436	19.11	411	68	0.923	354	10.5	0.001	168	744	6.5	0.026	14.6	189	4,158	5.36	2000	3594	0.446
1110	3	317	2.75	284	39	0.017	124	1.42	0.001	74	327	6.7	0.010	13.9	78	2,224	3.47	709	1859	0.106
Statistical Summary																				
Maximum ³		686	38.5	595	142	0.923	354	32.38	1.588	256	1135	6.9	0.062	19.5	406	5444	6.79	2167	4866	1.48
Average		411	17	443	92	0.184	204	8.04	0.168	145	642	6.6	0.032	16.4	247	3767	3.92	1555	3400	0.549
Flow Weighted ⁴		420	16.2	455	93	0.178	183	7.13	0.218	130	576	6.6	0.033	16.4	212	3,794	4.09	1,547	3,453	0.556

¹ Parameter values are the averages for each well from reported results in the timeframe 2000 through May 2014.

² The well flow rates were used as the basis for influent concentration data presented in the SOW.

³ The value shown as "Maximum" are maxima of the well averages. The value shown as "Average" is a straight average of all of the well average values shown on this table.

⁴ The "Flow Weighted" values are calculated from average concentrations and account for each well's proportionate contribution to the total flow.

Table 4: Comparison of Tuba City Site Groundwater Data for Selected Parameters

Parameter ¹	Operational Data ²		Combined Influent ³		Average well data 2000-2014 ⁴		IDB Value ⁵
	100 gpm	40 gpm	Total	Dissolved	Flow Weighted Avg	Maximum	
Alkalinity, Total (as CaCO ₃)	-	-	355	-	420	686	420
Ammonia Total (as N)	13	17	19	-	16.2	38.5	19
Calcium	400	500	450	445	455	595	455
Chloride	75	100	100	-	93	142	100
Iron	-	-	<0.1	<0.1	0.178	0.923	0.178
Magnesium	-	-	165	165	183	354	183
Manganese	-	-	6.05	6.05	7.13	32.38	7.13
Molybdenum	-	-	0.077	0.08	0.218	1.588	0.218
Nitrate (as N)	90	113	100	-	130	256	130
Selenium	-	-	0.026	0.027	0.033	0.062	0.033
Silica	-	-	15	16	16.4	19.5	16.4
Sodium	-	-	255	260	212	406	260
Specific Conductance (uS/cm)	3,500	4,500	3,875	-	3,794	5,444	3875
Sulfate	1,500	2,000	1,600	-	1,547	2,167	1600
Total Dissolved Solids	3,000	4,000	3,550	-	3,453	4,866	3550
Uranium	0.35	0.45	0.51	0.53	0.556	1.48	0.556
pH (s.u.)	6.6	6 to 7	7.13	-	6.6	6.9	7.13

¹ Units are mg/L unless otherwise noted.

² The 100 gpm concentrations are based on the weekly concentration measurements of the Site's treatment plant influent. The 40 gpm concentration values were calculated and intended to represent a weighted average based on only the wells in the "hot spot" needed to contain the plume.

³ Combined influent collected on 5/13/2014, for use in bench-scale treatability testing.

⁴ GEMS data from 2000-2014 from Wells 1105, 1103, 1101, 1104, 1102, 1121, 1120, 1108, 1106, 1119, 1122, 1111, 1109, 1110. The "Flow Weighted Avg" values are calculated from the well average values, but also weighted according to the average flow shown for each well. The value shown as "Maximum" is the maximum of the well averages.

⁵ To provide a conservative influent basis, the IDB value is the higher of the May 13, 2014 combined influent sample and the average historical well data from 2000 to 2014.

Table 5: Groundwater Remediation Goals

Parameter ¹	Treatment Goal ²
Sulfate	250
Chloride	250
Nitrate	44
Nitrate (as N)	10
Uranium	0.044
Total Dissolved Solids	500
Molybdenum	0.1
Selenium	0.01
pH (s.u.)	6.5 - 8.5

Notes:

¹ Units are mg/L unless otherwise noted.

² Nitrate, molybdenum, selenium, and uranium values are from EPA 40 CFR 192. Others are based on agreements with stakeholders.

Table 6: IDB Values and Required Removal

Parameter ¹	IDB Value	Treatment Goal	Required Removal (%)
Alkalinity, Total (as CaCO ₃)	420		
Ammonia Total as N	19		
Calcium	455		
Chloride	100	250	0%
Iron	0.178		
Magnesium	183		
Manganese	7.13		
Molybdenum	0.218	0.1	54%
Nitrate (as N)	130	10	92%
Selenium	0.033	0.01	70%
Silica	16.4		
Sodium	260		
Specific Conductance (uS/cm)	3875		
Sulfate	1600	250	84%
Total Dissolved Solids	3550	500	86%
Uranium	0.556	0.044	92%
pH (s.u.)	7.13	6.5 - 8.5	

Notes:

¹ Units are mg/L unless otherwise noted.

Attachment C

**Bench-Scale Test Plan and
Bench-Scale Treatability Results Technical Memorandum**

This page intentionally left blank



REPORT

WORK PLAN FOR BENCH-SCALE TREATABILITY TESTING

ALTERNATIVE ANALYSIS FOR CONTAMINATED GROUNDWATER TREATMENT TECHNOLOGIES

Tuba City, Arizona

Submitted To: S.M. Stoller Corporation
2597 Legacy Way
Grand Junction, CO 81503

Submitted By: Golder Associates Inc.
44 Union Boulevard, Suite 300
Lakewood, CO 80228 USA

Revision 1, May 29, 2014

Project No. 140-1485

A world of
capabilities
delivered locally





Table of Contents

1.0	INTRODUCTION.....	1
2.0	OBJECTIVES.....	2
3.0	BENCH TESTING STRATEGY	3
3.1	Electrocoagulation.....	3
3.2	Reverse Osmosis.....	3
4.0	TESTING EXECUTION.....	4
5.0	SUPPLEMENTAL SAMPLE COLLECTION.....	5
5.1	Supplemental EC Trials	5
6.0	DATA COLLECTION.....	7
6.1	Quality Assurance	7
6.2	Health & Safety	9

List of Tables

Table 1	Summary of Supplemental EC Trials
Table 2	Parameters for RO and EC Analyses
Table 3	Analytical Method and Quality Control Information



1.0 INTRODUCTION

Golder Associates Inc. (Golder) has been engaged by The S.M. Stoller Corporation (Stoller) to provide a groundwater treatment alternative analysis for the U.S. Department of Energy's (DOE) legacy site near Tuba City, Arizona. Alternative analysis will be focused on commercially available technologies to replace the existing treatment system which is nearing the end of its design life and has become difficult to operate and maintain. The technologies to be evaluated include evaporation (mechanical and enhanced passive/solar), reverse osmosis (RO), and electrocoagulation (EC). Evaluation will combine results from bench-scale treatability testing, theoretical calculations, and software modeling to optimize project cost- and schedule-efficiency.

This work plan provides an overview of bench-scale treatability test objectives, strategy, execution, and data collection, in support of technology evaluation and development of treatment alternatives for the Tuba City site.



2.0 OBJECTIVES

Testing objectives include:

- Development of an influent evaluation basis water quality characterization. Samples collected simultaneously with the bulk sample (to be utilized for bench trials) will be analyzed for contaminants of concern and other parameters that may impact the treatment efficiency of the technologies under evaluation. The analyte list is provided in Table 2, below. Analyses will be repeated with samples drawn from the bulk drums prior to initiation of bench test work.
- Determination of the water quality characteristics of RO treated effluent (permeate) and RO brine (reject) streams at a target permeate recovery rate of 70 percent. The initial water quality achievable at 70 percent recovery will represent optimum results for RO treatment, as over time, the RO membranes wear and treated effluent quality is reduced. RO permeate and brine quality will provide points of reference for RO modeling and literature review for projection of long-term RO treatment efficiency.
- Determination of the optimum water quality achievable through use of EC as a primary treatment process.



3.0 BENCH TESTING STRATEGY

3.1 Electrocoagulation

EC, as a “standalone” treatment, is expected to effectively remove uranium but is not expected to produce a treated effluent stream in compliance with all of the site’s groundwater treatment objectives. Highly soluble constituents such as nitrate and sulfate will not be effectively removed by EC and will require a downstream polishing process. Bench-scale treatability testing of EC will be performed to determine the optimum effluent quality that can be produced, and to determine optimal operational parameters including influent pH, EC anode blade types (iron and/or aluminum), and residence time. Bench testing of EC on raw groundwater will provide an indication of its efficiency as a pretreatment process to be utilized upstream from an RO or enhanced evaporation process.

3.2 Reverse Osmosis

RO can be expected to produce a high quality treated effluent. The contaminants of concern (uranium, sulfate, and nitrate) can all be effectively removed by RO, although the nitrate rejection is expected to decrease with membrane age and cleaning cycles. Pretreatment to remove or buffer the effects of scaling/fouling compounds may also be required. Bench-scale testing of RO will be performed to determine the upper bound of permeate quality and to produce brine for additional testing. The long-term effectiveness of RO treatment can only be projected in a longer continuous flow test in order to determine the gradual decrease in treatment efficiency, membrane fouling or scaling issues, and membrane cleaning/replacement frequencies. After determining permeate and brine characteristics in bench testing, the main tool used for RO process evaluation will be software modeling, coupled with experience on treatment of similar waters.



4.0 TESTING EXECUTION

Testing will be performed at Hazen Research, Inc. (Hazen) in Golden, Colorado. Golder staff will be present during all testing; however, Hazen technicians will be responsible for the hands-on execution. Approximately 100 gallons of water from the Site will be tested over a two-day period using two different technologies: electrocoagulation (EC) and reverse osmosis (RO). Powell Water Systems will supply a bench-scale EC unit and also provide onsite technical support during the EC testing. The RO system will be provided by Golder and is a single membrane bench-scale unit. A new DOW BW30-2540 brackish water membrane will be used.

Planned test conditions are listed below, but may be modified based on interim results and observation, as necessary for optimal results:

- RO testing
 - Approximately ninety gallons of raw water will be processed through the bench-scale RO system at a 70 percent recovery rate, generating about 63 gallons of high quality permeate, and 27 gallons of brine.
 - Analytical samples for raw water, permeate and brine will be obtained. A duplicate sample of one of the streams will be collected and submitted as a quality control measure.
- EC testing
 - A sample of raw water will be collected for analysis, prior to EC trials.
 - Raw water will be tested using EC. EC trials can be completed using three- to four-liter sample volumes to obtain an adequate volume of effluent for analysis. EC operational parameters to be tested are influent pH, residence time, and anode blade type. Planned trials, subject to change based on interim observations and results include:
 - Using iron anode blades with influent pH as received, at three residence times (1, 3, and 5 minutes);
 - Using iron anode blades at adjusted pH values (expected to be elevated) at three residence times;
 - Using aluminum anode blades or a combination of aluminum and iron blades at the optimal pH and residence time conditions from the iron blade testing; and
 - Other combinations of blade type, pH, and residence time if deemed necessary.
 - Samples of EC treated effluent will be taken after coagulated solids have settled. Samples will be filtered (0.45 μm) prior to analytical testing.

After completion of the trials, all materials will be properly disposed of by Hazen.



5.0 SUPPLEMENTAL SAMPLE COLLECTION

The initial bulk water sample (collected and shipped from the site on April 30) was found to have unusually high concentrations of sodium and chloride. The bulk sample was collected from the plant headworks sampling port, however the extraction well pumps were not operating at the time that the sample was drawn. It is suspected that water flowed back from the feed tank, and was cross-contaminated with ion exchange system regenerant solution (sodium chloride).

It was determined that RO testing of the unrepresentative water sample would yield no useful results, and that a second bulk sample should be collected. The second sample was collected and shipped on May 15. Extraction well pumps were in operation throughout the sample collection duration, and conductivity was field-measured as an indicator of the sample's representativeness. RO testing was performed on May 22, using the second bulk sample as influent.

In consultation with the EC subject matter expert and supplier (Scott Powell of Powell Water Systems) it was determined that the elevated concentrations of sodium and chloride in the first bulk sample would not adversely impact the validity of EC test data with regard to metals removal. EC testing as described in Section 4.0 above, was performed on May 14 using the sodium chloride-contaminated bulk sample. During the May 14 testing, it was decided to run additional EC trials on the second bulk sample for the following reasons:

- For validation of the assumption that elevated sodium and chloride concentrations did not have a significant impact on the May 14 EC trial results;
- To confirm results of the best trial conditions previously tested (blade type, residence time and influent pH); and
- To expand the EC testing scope to include evaluation of EC removal efficiency for total nitrogen and sulfate through addition of phosphate and zinc reagents, respectively.

Supplemental EC trials were planned following receipt of analytical data from the first round of EC trials. Supplemental trials, to be performed on June 3, are outlined in section 5.1, below.

5.1 Supplemental EC Trials

Two of the original testing variables, influent pH and blade type, can be narrowed down based on results from the first round of EC effluent analytical results. Raising the influent pH to 9 and lowering the influent pH to 5 prior to EC trials did not have a significant effect on EC treated effluent quality. Supplemental trials will be performed on pH as received, only. Similarly, use of iron blades alone provided better results than the mixture of iron and aluminum blades or all aluminum blades. All supplemental trials will be performed with iron blades only.



Planned supplemental EC trials (all with iron blades, all at “as received” influent pH) are summarized in Table 1. Trial conditions may be added, deleted or changed based on interim results.

Table 1: Summary of Supplemental EC Trials

Trial	Testing For	New Parameter	Retention	Rationale
1	Metals removal efficiency	N/A	1 min	Verify result from first round EC trials
2		N/A	2 min	New retention time
3		N/A	3 min	Verify result from first round EC trials
4		N/A	4 min	New retention time
5		N/A	2 min	Quality control replicate
6	Effluent pH adjustment	HCl addition to treated effluent, to a final pH of 8	1 min	Verify effluent pH adjustment parameter
7			3 min	Verify effluent pH adjustment parameter
8	Nitrate removal	Phosphorus reagent at stoichiometric concentration	1 min	Determine nitrate removal efficiency and effluent TDS concentration while varying reagent concentration and retention times
9			3 min	
10		Phosphorus reagent at slight excess concentration	1 min	
11			3 min	
12	Sulfate removal	Zinc reagent at stoichiometric concentration	1 min	Determine sulfate removal efficiency and effluent TDS concentration while varying reagent concentration and retention times
13		Zinc reagent at slight excess concentration	3 min	



6.0 DATA COLLECTION

As many as twelve analytical samples may be sent to ALS Environmental (Fort Collins, CO) from bench-scale trials. Analytical parameters are summarized in Table 2. Also listed in Table 2 are the required volumes for each analytical test.

Secondary waste from the EC trials (coagulated solids) will not be analyzed.

Table 2: Parameters for RO and EC Sample Analyses

Parameter	Analyte List for RO	Bottle Required	Analyte List for EC	Bottle Required
pH	x	1 L poly, Unpreserved	x	1 L poly, Unpreserved
Conductivity	x		x	
Total dissolved solids	x		x	
TSS	x		x	
Total alkalinity	x		x	
Chloride	x		x	
Fluoride	x		x	
Sulfate	x		x	
Nitrate	x		x	
Cation/Anion Balance	x	NA		NA
Ammonia, as N	x	250 mL poly, H ₂ SO ₄	x	250 mL poly, H ₂ SO ₄
Phosphorus	x		x	
Aluminum, dissolved	x	250 mL poly, HNO ₃ if field filtered. 250 mL poly unpreserved if lab filtered.	x	250 mL poly, HNO ₃ if field filtered. 250 mL poly unpreserved if lab filtered.
Barium, dissolved	x			
Iron, dissolved	x		x	
Manganese, dissolved	x			
Molybdenum, dissolved	x		x	
Selenium, dissolved	x		x	
Silica, dissolved	x			
Strontium, dissolved	x			
Uranium, dissolved	x		x	
Total Volume Required		3250 mL		1500

6.1 Quality Assurance

Analytical Quality Assurance begins with use of a certified analytical laboratory. The Fort Collins branch of ALS Environmental performs analytical services for Stoller under the DOE Legacy Management Support contract and will be providing all analytical services to the bench testing program. ALS



Environmental laboratories employ full-time, trained QA/QC chemists to help maintain the quality system, conduct internal audits and assist in training and compliance.

An important aspect of the Quality Management System is the periodic audits and assessments by local accreditation bodies. Accreditations for ALS Environmental labs are based on the requirements of ISO/IEC 17025:2005. Accreditations are held for specific tests as related to each laboratory Scope of Accreditation. Copies of individual laboratory Scope of Accreditation are available upon request.

Routine laboratory control samples used in ALS Environmental laboratories include:

- Certified Reference Materials
- Laboratory Duplicates
- Laboratory Control Spikes
- Matrix Spikes
- Surrogates
- Secondary and project Standards
- Inter-Laboratory (Proficiency) Testing

For the bench-testing program a standard Level 2 data package will be provided by ALS Environmental and includes the following:

- Report Description
- Cover Letter or Case Narrative with Project Chemist Sign-Off
- Analytical Results (with surrogates if applicable)
- Analytical Batch QA/QC Results (BLKs, LCSs)
- Statement of Data Qualifications
- Field Chain-of-Custody Form



Analytical methods, reporting limit, and quality control information for each parameter is listed in Table 3.

Table 3: Analytical Method and Quality Control Information

Parameters	Analytical Method	Reporting Limit (µg/L, except as noted)	Laboratory Control Sample Limits (%)	Relative Percent Difference
pH	SM4500-H	0.1 pH units	90-110	15
Specific Conductivity	SM2510b	100	NA	10
Total Alkalinity	SM2320	5,000	85-115	15
Total Dissolved Solids	SM2540C	20,000	85-115	5
Total Suspended Solids	SM2540D	20,000	85-115	5
Chloride	EPA300.0	200	90-110	15
Fluoride	EPA300.0	100	90-110	15
Nitrate, as N	EPA300.0	200	90-110	15
Sulfate	EPA300.0	1,000	90-110	15
Ammonia, as N	EPA350.1	100	90-110	20
Total Phosphorus	EPA365.2	50.0	80-120	20
Silicon as SiO ₂	EPA200.7	46.0	80-120	20
Aluminum	EPA200.8	50	85-115	30
Arsenic	EPA200.8	2	85-115	30
Barium	EPA200.8	1	85-115	30
Calcium	EPA200.8	1,000	85-115	30
Iron	EPA200.8	100	85-115	30
Magnesium	EPA200.8	100	85-115	30
Manganese	EPA200.8	2	85-115	30
Molybdenum	EPA200.8	1	85-115	30
Potassium	EPA200.8	1,000	85-115	30
Selenium	EPA200.8	1	85-115	30
Sodium	EPA200.8	1,000	85-115	30
Strontium	EPA200.8	1	85-115	30
Uranium	EPA200.8	0.1	85-115	30

In addition to the laboratory quality program, Golder will submit a minimum of one duplicate sample for every 10 analyses. QC data will be promptly reviewed and any discrepancies will be resolved with ALS' assistance.

6.2 Health & Safety

All "hands-on" test work will be performed by Hazen technicians, under the requirements of Hazen's Health & Safety policy and procedures. Standard work wear (long sleeves, long pants, sturdy closed-toe shoes) must be worn by all observers (Stoller, DOE, Golder, and Powell Water Systems). Additional personnel protective equipment (lab coats, safety glasses) may be provided, as necessary.

Date: July 14, 2014
To: Mr. Ken Karp
From: Bridgette Hendricks
cc: Pete Lemke
RE: TREATABILITY TESTING RESULTS FOR TUBA CITY GROUNDWATER TREATMENT

Project No.: 1401485
Company: S.M. Stoller Corporation
Email: Bridgette_Hendricks@golder.com

1.0 INTRODUCTION

Golder Associates Inc. (Golder) has been engaged by S.M. Stoller Corporation (Stoller) to provide a groundwater treatment alternative analysis for the U.S. Department of Energy's (DOE) legacy site (the Site) near Tuba City, Arizona. In support of alternatives development, bench-scale treatability testing and groundwater characterization has been completed. Two bulk groundwater samples were collected and shipped to Denver to support three days of bench-scale testing. This technical memorandum provides a summary of the bench-scale treatability testing approach and results.

2.0 TEST OVERVIEW AND OBJECTIVES

The technologies to be evaluated include evaporation (mechanical and enhanced passive/solar), reverse osmosis (RO), and electrocoagulation (EC). EC and RO processes were evaluated through bench-scale testing.

Testing was conducted at Hazen Research, Inc. (Hazen) in Golden, Colorado with Golder staff present during testing. Powell Water Systems supplied a bench-scale EC unit and provided technical oversight during the EC testing. A single membrane bench-scale RO unit with a new DOW BW30-2540 brackish water membrane was used for RO testing.

Objectives include:

- Development of an influent evaluation basis water quality characterization. Samples collected simultaneously with the bulk sample (to be utilized for bench trials) were analyzed for contaminants of concern and other parameters that may impact the treatment efficiency of the technologies under evaluation.
- Determination of the water quality characteristics of RO treated effluent (permeate) and RO brine (reject) streams at a target permeate recovery rate of 70 percent.
- Determination of the water quality achievable through use of EC as a primary treatment process.



2.1 EC Testing

The EC testing included the following parameters:

- Reaction times – from 1 minute to 10 minutes
- Blade types – all iron, all aluminum, and “50/50” combination
- Influent pH – pH “as received”, a lower initial pH (5) and a higher initial pH (9)
- Co-treatment reagents – phosphate was added to promote precipitation of ammonia and zinc was added to promote the precipitation of sulfate

2.2 RO Testing

The RO test approach was to operate the RO unit in a recycle mode to achieve a permeate recovery of seventy percent, and to develop water quality characterizations for RO permeate and brine streams. It is important to note that the permeate quality characterization from a single run using a new membrane is representative of best case conditions. Changes in permeate quality over time as the membrane ages and goes through cleaning cycles cannot be projected in a short-duration bench test.

3.0 BENCH TESTING RESULTS

Two bulk groundwater shipments were made to Hazen laboratories to support two rounds of EC testing and one round of RO testing. The first bulk shipment was found to have unusually high concentrations of total dissolved solids (TDS), sodium, and chloride as a result of inadvertent mixing with spent ion exchange regenerant. The decision was made to continue with the EC testing, as the high TDS was not expected to adversely affect the treatment efficiency or the validity of results for contaminants of concern.

RO testing could not be performed with the first bulk sample, as the high TDS was expected to have a significant impact on RO operation and removal efficiency for contaminants of concern.

3.1 First Round EC Testing

Photos of the bench-scale EC set-up and treated water prior to suspended solids removal are provided in Attachment 1. Table 1 provides the test conditions, field measurements and analytical data from the first round of EC testing. The total suspended solids (TSS) concentration shown under “Field Data and Test Conditions” is the TSS of the treated water and represents the sludge generated on a dry weight basis.

General observations regarding the treated water quality at various trial conditions include:

- All of the target metals of concern (molybdenum, uranium, and selenium) are removed by the EC treatment with iron blades.
- No advantage was observed in trials for influent pH adjustment.
- TDS, chloride, and sulfate removal were not achieved by any of the treatment conditions.
- Some nitrate was conversion to ammonia was apparent from decreased concentration of nitrate and increased concentration of ammonia in the EC treated effluent.

- Effluent pH was higher than influent pH for all trials.
- Removal of parameters that may cause fouling or scaling issues with RO or evaporation treatment such as manganese, silica and hardness (calcium and magnesium) was also achieved.

Round 1 EC results were used as a guide for the second round of EC testing. No additional trials utilizing aluminum blades were planned, as they did not perform as well as iron blades and increases in aluminum concentration in treated effluent were observed. Influent pH adjustment was not considered further as the pH increase and decrease trials did not effectively change the treatment efficiency.

The second round of EC testing was focused on longer retention times and evaluation of co-treatment reagents for removal of nitrogen species and sulfate.

3.2 RO Testing

The bench-scale RO is a single membrane system. Brine is recycled until the desired permeate recovery is achieved. Attachment 2 shows a photograph of the laboratory RO unit with a cartridge prefilter (front cylinder) and a single membrane cartridge (back stainless steel cylinder). Approximately fifty gallons from second bulk sample of groundwater was treated to produce 35 gallons of permeate and 15 gallons of brine or a seventy percent permeate recovery. The analytical results for the second bulk sample along with the RO permeate and brine are shown on Table 2. The RO permeate meets treatment goals for all parameters with the exception of nitrate and results in a final TDS of 150 mg/L.

3.3 Second Round of EC Testing

Table 3 provides the field data, test conditions, and analytical results from testing of the second bulk sample of water. Attachment 3 presents photographs from the second round of EC treatment. This sample was representative of groundwater quality with a TDS of approximately 3,400 mg/L and all other individual parameter concentrations reasonably close to their historic average values. Other general observations regarding the second round of EC testing include:

- All metals treatment goals were achieved at a 3-minute reaction time.
- Longer reaction time was required to achieve nitrate removal. Nitrate was converted to ammonia and it appears that ammonia was stripped due to the increase in both pH and temperature of the water at the 10 minute retention time test condition.
- The phosphate addition trials did not show improved removal of nitrogen species.
- TDS and sulfate removal were not achieved at any treatment conditions. Test conditions 2ECT-13 and 2ECT-14 were included to evaluate the potential for sulfate removal through addition of co-treatment reagents (zinc and lead). Neither trial showed an increase in sulfate removal.
- Longer reaction times result in a greater generation of secondary waste volume (sludge).

4.0 DATA QUALITY REVIEW

The samples were analyzed by the Fort Collins branch of ALS Environmental. This laboratory maintains many certifications including NELAC accreditation and performs analytical services for Stoller under the DOE Legacy Management Support contract. Accreditations for ALS Environmental labs are based on the requirements of ISO/IEC 17025:2005. Accreditations are held for specific tests as related to each laboratory Scope of Accreditation. Copies of individual laboratory Scope of Accreditation are available upon request. Three methods of confirming the data quality were utilized for the bench testing samples as follows:

- A review of the analytical laboratory reports which included a standard Level 2 data package with the results of internal laboratory quality check results.
- Blind duplicate samples were submitted.
- Golder's review of ALS data included:
 - Comparison of total recoverable and dissolved metals, to ensure that the total recoverable values were consistently higher than the dissolved values
 - Cation–anion balance calculation
 - Comparison of the analytical value for TDS and a TDS value calculated as the sum of all ion concentrations

All reviews showed the data to be of acceptable quality.

4.1 Internal ALS Results

For the bench-testing program a standard Level 2 data package was included with each analytical data report. In addition to the analytical data on the bench testing samples the data from the internal quality control procedures and samples was also reported. The laboratory quality measures were all within the requirements with a few exceptions that do not impact the interpretation of the results as follows:

- The nitrate hold time was exceeded in most samples. This was not due to a lag at the laboratory, rather the shipping time or lag at the treatability lab between sample collection and shipping. ALS notified Golder each time the samples arrived out of hold time for nitrate and Golder provided the verification that analysis should continue.
- Serial dilutions were not within acceptable criteria for one barium, one silicon and three selenium analyses over the course of the test program which included 30 analytical samples. This indicates matrix interference and the results reported are estimated. The results flagged because of unacceptable serial dilutions are all reasonable and the flag does not impact the interpretation of the results.

4.2 Duplicate Results

A blind duplicate was submitted and the results are shown on Table 4. The relative percent difference (RPD) between the original and the duplicate is consistently within the acceptable range of twenty percent with the exception of the phosphorus result. Phosphorus is reported at a low value, which inflates the RPD.

Both bulk shipments were sampled immediately upon receipt and during EC testing, providing analytical results for samples drawn from the same source (drums) but approximately two weeks apart. Tables 1 and 3 show the results of the drum sampling. For the first bulk sample the correlation between the raw water (sampled April 30 upon receipt at Hazen) and sample ECR-1 (collected May 14 at EC testing round one) is outside the twenty percent range for TDS, chloride, sodium, calcium, and magnesium. For the second bulk sample, correlation between the receipt sample (collected on May 13, 2014) and sample 2ECT-1 (collected on June 3 at EC testing round two) is within a twenty percent relative percent difference with the exception of iron. Iron was reported at its detection limit of 0.1 mg/L upon receipt and 0.71 mg/L at initiation of EC testing round two.

5.0 CONCLUSIONS

Treatability data was reviewed to determine that its accuracy acceptably supports the intended use in alternatives evaluation. The data are useable to support the alternatives evaluation based on data quality calculations and observations as follows:

- The TDS measured by the analytical laboratory and calculated as a sum of the major ions are consistent and acceptable. The RO permeate had the greatest difference in measured and calculated TDS but also the lowest TDS so the higher difference is expected.
- The cation–anion balance closes with acceptable accuracy.
- The results for total and dissolved metals are as expected (total concentrations greater than dissolved) with few exceptions where the values are close and/or reported at very low levels.

RO and EC trials were run in accordance with the “*Work Plan for Bench-Scale Treatability Testing*” (Golder, May 2014) with the flexibility to alter trials based on observations during performance of testing. The test results as presented can be used to develop the influent water quality basis and evaluate contaminant removal by RO and EC treatment.

TABLES

Table 1: Results of First Round of EC Testing

Parameter	Units	Treatment Goal	Raw Water (4/30/14)		ECR-1 (Raw Feed)	EC Treated Water											
			TR	Dis		ECR-2	ECR-3	ECR-4	ECR-5	ECR-6	ECR-7	ECR-8	ECR-9	ECR-10	ECR-11	ECR-12	
Field Data and Test Conditions																	
pH Initial	SU		6.95	-	-	6.95	9	5	6.95	9	5	6.95	9	5	6.95	6.95	
pH Final	SU		-	-	-	9.17	9.22	8.96	8.27	8.85	7.25	8.26	8.57	7.16	8.86	-	
Blades	-		-	-	-	Fe	Fe	Fe	Al	Al	Al	Fe/Al	Fe/Al	Fe/Al	Fe	Fe	
Rxn Time	min		-	-	-	1	1	1	1	1	1	1	1	1	3	1	
TSS	mg/L		-	-	-	6600	5600	5300	8200	6700	5400	6800	6500	8100	13000	-	
Analytical Data																	
Bicarbonate as CaCO ₃	mg/L		380		390	69	74	92	150	170	130	260	170	180	20	-	
Carbonate as CaCO ₃	mg/L		20		20	82	120	70	48	74	20	74	100	20	240	-	
Total alkalinity as CaCO ₃	mg/L		380		390	150	200	160	190	240	130	330	270	180	250	-	
pH	SU	6.5 to 8.5	6.89		7.08	9	9.2	8.7	8.49	8.76	7.34	8.49	8.94	6.78	9.49	-	
Conductivity	umhos/cm		50700		47700	46900	47000	45900	46300	46500	45900	46800	46400	46500	46800	-	
TDS	mg/L	500	21000		31000	30000	30000	30000	30000	30000	30000	30000	30000	30000	30000	-	
TSS	mg/L		20		20	20	20	20	20	20	20	20	44	51	20	-	
Fluoride	mg/L		5		10	10	10	10	10	10	10	10	10	10	10	-	
Chloride	mg/L	250	11000		15000	15000	13000	17000	15000	15000	15000	16000	14000	14000	15000	-	
Nitrate (as N)	mg/L	10	100		110	93	99	99	100	100	98	100	99	97	74	-	
Ammonia (as N)	mg/L		-		9	23	16	16	11	11	11	15	16	16	41	-	
Phosphorus	mg/L		-		0.061	0.067	0.05	0.05	0.05	0.05	0.05	0.05	0.05	0.05	0.11	-	
Sulfate	mg/L	250	1700		1700	1600	1600	1600	1500	1600	1400	1500	1500	1500	1600	-	
Metals																	
Aluminum	mg/L		0.05	0.05	0.05	0.05	0.05	0.05	6.8	13	0.14	5	27	0.29	0.05	0.05	
Arsenic	mg/L		0.081	0.074	0.077	0.002	0.002	0.002	0.002	0.002	0.002	0.002	0.002	0.002	0.002	0.002	
Barium	mg/L		0.02	0.019	0.027	0.076	0.017	0.082	0.027	0.015	0.045	0.024	0.021	0.039	0.0056	0.052	
Calcium	mg/L		170	160	270	120	100	220	140	150	230	190	130	230	24	240	
Iron	mg/L		0.1	0.1	0.1	0.41	0.33	12	0.1	0.1	0.1	0.35	0.1	26	0.23	170	
Magnesium	mg/L		54	52	79	32	42	49	29	29	59	25	9.3	28	3.3	40	
Manganese	mg/L		2.2	2.1	3.1	0.47	0.29	1	0.045	0.036	1.2	0.13	0.018	1.5	0.016	6.3	
Molybdenum	mg/L	0.1	0.13	0.12	0.13	0.012	0.02	0.015	0.11	0.12	0.08	0.056	0.072	0.043	0.035	0.0074	
Potassium	mg/L		6.2	6.1	7.2	7.7	7.1	5.9	6.4	7	6.8	6.6	7.2	6.7	6.7	6.8	
Selenium	mg/L	0.01	0.026	0.025	0.029	0.0094	0.016	0.013	0.024	0.023	0.024	0.02	0.02	0.019	0.0046	0.014	
Sodium	mg/L		8000	7600	13000	12000	13000	11000	12000	13000	12000	12000	13000	12000	12000	12000	
Strontium	mg/L		1.5	1.4	2.2	1.2	0.89	2	1.3	1.4	1.9	1.7	1.5	1.9	0.21	2	
Uranium	mg/L	0.044	0.52	0.51	0.56	0.00069	0.00099	0.0053	0.018	0.025	0.0064	0.0082	0.0062	0.0043	0.00059	0.001	
Silica	mg/L		14	13	13	0.55	0.97	1.5	0.11	0.11	1.5	0.29	0.12	1.2	0.098	2.3	

U Flag - Nondetect. Value shown is DL

E Flag - Exceeds calibration range.

Table 2: Results of Bench-Scale RO Treatment

Parameter	Units	Treatment Goal	5/14/2014		5/14/2014		5/14/2014		5/14/2014	
			Combined Inf		Combined Inf (Dup)		RO Brine		RO Permeate	
Total Alkalinity (CaCO ₃)	mg/L		350		360		990		6	
pH	SU	6.5 to 8.5	7.2		7.06		7.63		5.58	
Conductivity	umhos/cm		3890		3860		8860		170.1	
TDS	mg/L	500	3400		3700		10000		150	
TSS	mg/L		<20		<20		<20		<20	
Fluoride	mg/L		<0.2		<0.2		<0.5		<0.1	
Chloride	mg/L	250	100		100		280		3.3	
Nitrate (as N)	mg/L	10	100		100		260		15	
Ammonia (as N)	mg/L		19		19		42		6	
Phosphorus	mg/L		0.059		0.21		0.58		<0.05	
Sulfate	mg/L	250	1600		1600		4500		4.3	
			TR	Dissolved	TR	Dissolved	TR	Dissolved	TR	Dissolved
Aluminum	mg/L		<0.05	<0.05	<0.05	<0.05	<0.05	<0.05	0.058	<0.05
Arsenic	mg/L		0.052	0.058	0.054	0.054	0.17	0.16	<0.002	<0.002
Barium	mg/L		0.039	0.039	0.037	0.04	0.11	0.11	0.0013	<0.001
Calcium	mg/L		460	440	440	450	1200	1100	4.1	2.8
Iron	mg/L		<0.1	<0.1	<0.1	<0.1	<0.1	0.14	<0.1	<0.1
Magnesium	mg/L		170	160	160	170	480	450	1.3	1.1
Manganese	mg/L		6.2	6	5.9	6.1	18	17	0.051	0.036
Molybdenum	mg/L	0.1	0.076	0.081	0.077	0.079	0.24	0.22	0.001	<0.001
Potassium	mg/L		8.7	8.7	8.5	8.7	23	22	1.1	1.1
Selenium	mg/L	0.01	0.027	0.025	0.025	0.029	0.078	0.074	<0.001	<0.001
Sodium	mg/L		260	260	250	260	720	670	18	18
Strontium	mg/L		4	3.9	3.8	4	11	11	0.035	0.024
Uranium	mg/L	0.044	0.51	0.53	0.51	0.53	1.4	1.4	0.00095	0.00088
Silica	mg/L		15	16	15	16	40	40	0.33	0.31

Table 3: Second Round of EC Testing Results

Parameter	Units	Treatment Goal	Raw Water (5/13/14)		2ECT-1 (Raw Feed)	EC Treated Water													
			TR	Dis		2ECT-2	2ECT-3	2ECT-4	2ECT-5	2ECT-6	2ECT-7	2ECT-8	2ECT-9	2ECT-10	2ECT-11	2ECT-12	2ECT-13	2ECT-14	
Field Data and Test Conditions																			
pH Initial	SU				-	6.9	6.9	6.9	6.9	6.9	6.9	6.9	6.9	6.9	6.9	6.9	6.9	6.9	
pH Final	SU		-		-	7.99	9.32	9.39	9.24	9.44	9.17		8.36	9.49	7.97	9.86	9.48	9.41	
Blades	-		-		-	Fe	Fe	Fe	Fe	Fe	Fe	Fe	Fe	Fe	Fe	Fe	Fe	Fe	
Reaction Time	min		-		-	1	3	5	10	3	3	1	1	3	1	3	3	3	
Other Treatment (see notes below)											A	B	C	D	E	F	G	H	
TSS	mg/L		-		-	238	2750	7120	21600	3230	3130		824	6350	1610	5030	4590	4440	
Analytical Data																			
Bicarbonate as CaCO ₃	mg/L		-		360	180	9.5	20	5	5	17	120	200	5	190	5	5	5	
Carbonate as CaCO ₃	mg/L		-		20	20	51	100	36	68	47	20	20	22	5	26	61	76	
Total alkalinity as CaCO ₃	mg/L		350		360	180	61	110	47	75	64	120	200	58	190	110	70	84	
pH	SU	6.5 to 8.5	7.2		7.19	8.19	8.76	9.01	8.99	9	8.69	6.39	8.24	9.33	7.92	9.76	9.01	8.99	
Conductivity	umhos/cm		3890		3780	3590	3330	3190	3240	3350	3430	3620	3730	3300	4040	3620	3350	3300	
TDS	mg/L	500	3400		3400	3400	2800	2600	2700	3000	2900	3500	3500	2900	3200	2800	3100	3000	
TSS	mg/L		20		20	20	20	20	20	20	20	20	31	20	20	20	20	20	
Fluoride	mg/L		0.2		0.5	0.5	0.5	0.5	0.5	0.5	0.5	0.5	0.5	0.5	0.5	0.5	0.5	0.5	
Chloride	mg/L	250	100		100	100	100	110	140	100	120	100	99	100	98	100	100	100	
Nitrate (as N)	mg/L	10	100		100	100	96	44	1	92	91	100	100	98	97	80	94	81	
Ammonia (as N)	mg/L		19		17	20	32	63	29	36	36	18	19	27	21	41	34	49	
Phosphorus	mg/L		0.059		0.062	0.05	0.05	0.05	0.05	0.05	0.05	94	3	0.19	15	0.43	0.05	0.05	
Sulfate	mg/L	250	1600		1600	1600	1500	1500	1700	1500	1500	1600	1500	1300	1500	1400	1500	1500	
Metals																			
Aluminum	mg/L		0.05	0.05	0.05	0.05	0.05	0.05	0.05	0.05	0.05	0.05	0.05	0.05	0.05	0.05	0.05	0.05	
Arsenic	mg/L		0.052	0.058	0.055	0.002	0.002	0.002	0.002	0.002	0.002	0.049	0.013	0.002	0.023	0.002	0.002	0.002	
Barium	mg/L		0.039	0.039	0.037	0.031	0.052	0.072	0.16	0.048	0.042	0.0027	0.0068	0.013	0.001	0.0023	0.036	0.031	
Calcium	mg/L		460	440	480	410	390	350	440	370	380	470	350	330	110	90	380	360	
Iron	mg/L		0.1	0.1	0.71	0.1	0.38	0.56	1.6	0.1	0.1	0.1	11	0.43	0.1	0.19	0.56	0.73	
Lead	mg/L		-	-	0.0005	0.0005	0.0005	0.0005	0.0005	0.0005	0.0005	0.0005	0.0005	0.0005	0.0005	0.0005	0.0005	0.016	
Magnesium	mg/L		170	160	180	170	130	83	17	130	140	180	170	45	120	13	120	130	
Manganese	mg/L		6.2	6	6.5	1.5	0.75	0.54	0.53	0.53	0.38	2.9	1.2	0.24	0.088	0.032	0.58	0.65	
Molybdenum	mg/L	0.1	0.076	0.081	0.079	0.06	0.0081	0.0038	0.001	0.0092	0.013	0.07	0.07	0.017	0.066	0.029	0.0096	0.0086	
Potassium	mg/L		8.7	8.7	9.3	9.4	10	11	15	9.5	11	11	10	11	10	10	9.7	11	
Selenium	mg/L	0.01	0.027	0.025	0.029	0.027	0.0018	0.0013	0.001	0.0016	0.0012	0.027	0.024	0.0022	0.026	0.0027	0.001	0.001	
Sodium	mg/L		260	260	280	280	300	320	430	290	300	300	470	460	740	790	290	300	
Strontium	mg/L		4	3.9	4.1	3.6	3.9	3.5	4.8	3.6	3.6	3	2.7	3	0.75	0.85	3.6	3.8	
Uranium	mg/L	0.044	0.51	0.53	0.55	0.4	0.00013	0.00035	0.0001	0.0001	0.00028	0.0002	0.088	0.0001	0.00081	0.0001	0.00017	0.0001	
Zinc	mg/L		-	-	0.037	0.02	0.02	0.02	0.02	0.02	0.02	0.02	0.02	0.02	0.02	0.02	0.02	0.02	
Silica	mg/L		15	16	15	10	0.17	0.098	0.13	0.11	0.15	16	14	1	15	0.67	0.12	0.098	

U Flag - Nondetect. Value shown is DL.

- A - after EC treatment, settling and filtration the pH was reduced to 7.99 with HCl - 1.17 mL of 1 M HCl required per 2 L of sample.
- B - For removal of nitrogen species, 0.6 mL of 85% H₃PO₄ added to 3 L, pH dropped to 5.41.
- C - For removal of nitrogen species, 0.6 mL of 85% H₃PO₄ added to 3L, pH dropped to 5.92, 20.5 mL of 1 M NaOH added to increase pH to 6.85, temperature increased to 37 C after 3 min of treatment per 3 L.
- D - For removal of nitrogen species, 0.6 mL of 85% H₃PO₄ added to 3L, pH dropped to 5.9, added 30 ml of 1 M NaOH to increase pH to 6.86
- E - For removal of nitrogen species, 1.8 mL of 85% H₃PO₄ added to 3L, pH dropped to 3.08, added 58.15 ml of 1 M NaOH to increase pH to 6.86.
- F - For removal of nitrogen species, 1.8 mL of 85% H₃PO₄ added to 3L, pH dropped to 3.1, added 59.4 ml of 1 M NaOH to increase pH to 6.86.
- G - added 3.5 g Zn per 3 L for sulfate removal.
- H - added 11 g Pb per 3 L for sulfate removal.

Table 4: Second Bulk Sample Duplicate Results

Parameter	Units	Bulk Sample (upon receipt, May 14)		Bulk Sample (resampled June 3)		Relative Percent Difference	
		TR	Dissolved	TR	Dissolved	TR	Dissolved
Total Alkalinity (CaCO ₃)	mg/L	350		360		-3%	
pH	SU	7.2		7.06		2%	
Conductivity	umhos/cm	3890		3860		1%	
TDS	mg/L	3400		3700		-9%	
TSS	mg/L	<20		<20		-	
Fluoride	mg/L	<0.2		<0.2		-	
Chloride	mg/L	100		100		0%	
Nitrate (as N)	mg/L	100		100		0%	
Ammonia (as N)	mg/L	19		19		0%	
Phosphorus	mg/L	0.059		0.21		-256%	
Sulfate	mg/L	1600		1600		0%	
		TR	Dissolved	TR	Dissolved	TR	Dissolved
Aluminum	mg/L	<0.05	<0.05	<0.05	<0.05	-	-
Arsenic	mg/L	0.052	0.058	0.054	0.054	-4%	7%
Barium	mg/L	0.039	0.039	0.037	0.04	5%	-3%
Calcium	mg/L	460	440	440	450	4%	-2%
Iron	mg/L	<0.1	<0.1	<0.1	<0.1	-	-
Magnesium	mg/L	170	160	160	170	6%	-6%
Manganese	mg/L	6.2	6	5.9	6.1	5%	-2%
Molybdenum	mg/L	0.076	0.081	0.077	0.079	-1%	2%
Potassium	mg/L	8.7	8.7	8.5	8.7	2%	0%
Selenium	mg/L	0.027	0.025	0.025	0.029	7%	-16%
Sodium	mg/L	260	260	250	260	4%	0%
Strontium	mg/L	4	3.9	3.8	4	5%	-3%
Uranium	mg/L	0.51	0.53	0.51	0.53	0%	0%
Silica	mg/L	15	16	15	16	0%	0%

**ATTACHMENT 1
FIRST ROUND EC TESTING PHOTOS**

PHOTO 1
Electrocoagulation 1-
L Bench-scale Unit
with Iron Blades
Installed



PHOTO 2
Floc formation

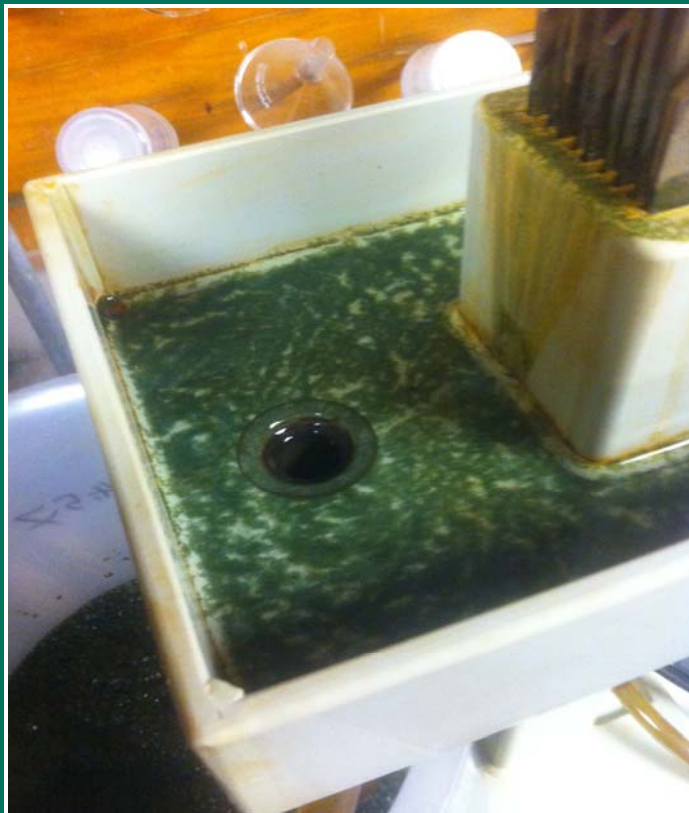

PHOTO 3
Bench EC unit in operation



PHOTO 4
Comparison of clean (left) and dirty (right) blades



PHOTO 5
High TDS
groundwater after 1
minute of treatment
with pH adjustment,
after settling. As-
received pH (left), pH
9 (center), pH 5
(right).

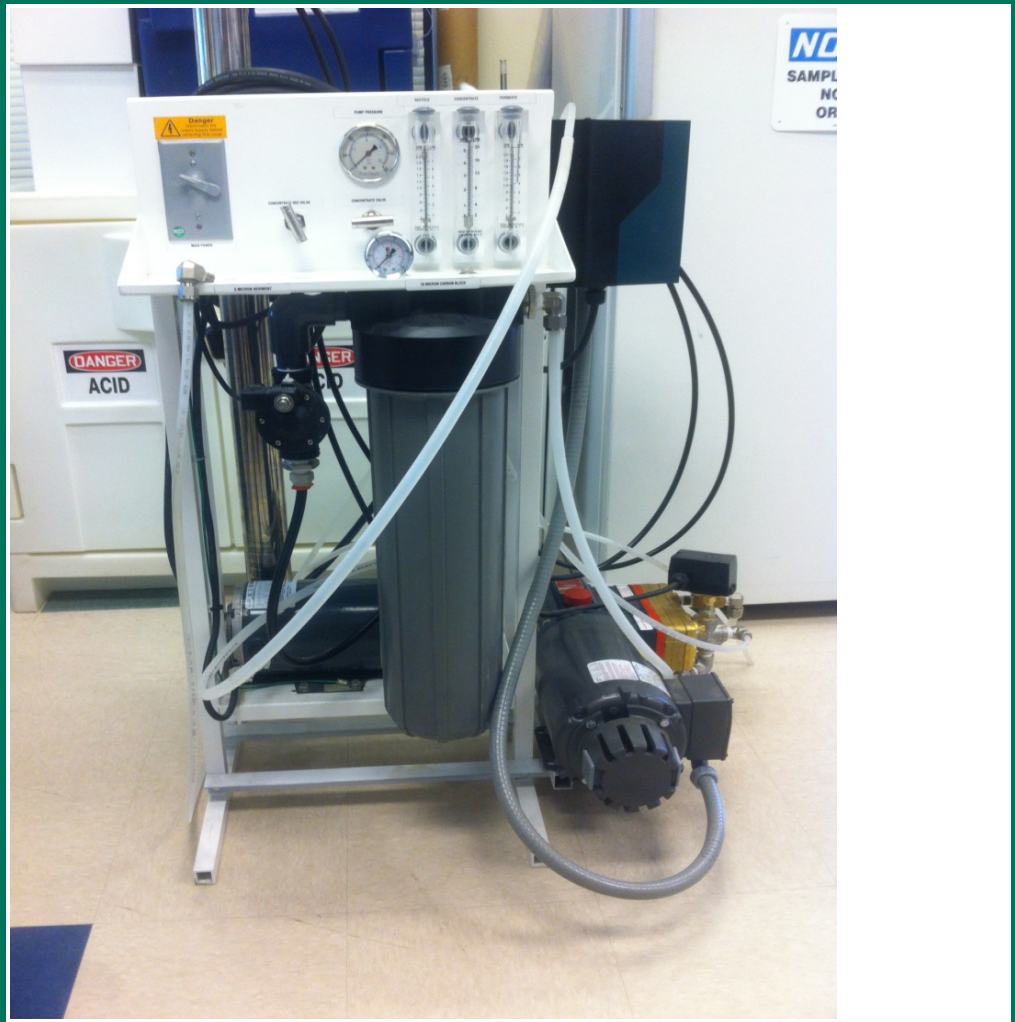

PHOTO 6
Comparison of EC
treatment with Iron
Blades and
Aluminum Blades



**ATTACHMENT 2
RO TESTING PHOTOS**

PHOTO 1
Bench RO Unit



**ATTACHMENT 3
SECOND ROUND EC TESTING PHOTOS**

PHOTO 1
Bench EC unit in operation



PHOTO 2
Comparison of 1 min and 3 min of treatment, iron blades, 15 minutes of settling.

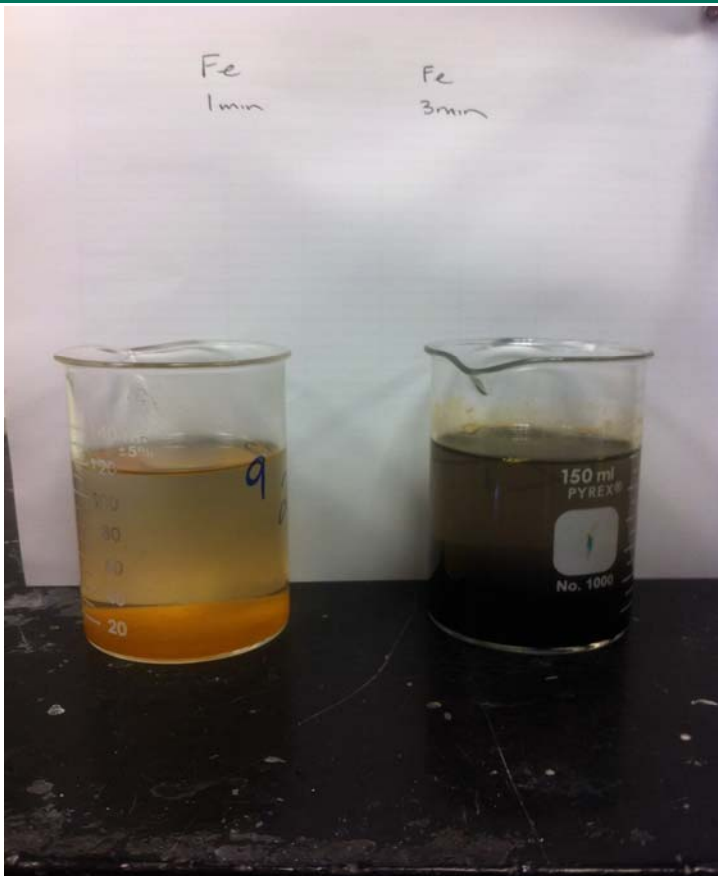

PHOTO 3
EC treatment (iron blades) with Additives. From left to right: 3 min treatment, phosphoric acid (0.6 mL 85% H_3PO_4); 1 min treatment, phosphoric acid (1.8 mL 85% H_3PO_4); 3 min pretreatment, phosphoric acid (1.8 mL 85% H_3PO_4); 3 min treatment 3.6 g Zn/3L; 3 min treatment 11 g Zn/3L)

